

MICROJET RECORDER E

TYPE: PHE — 2

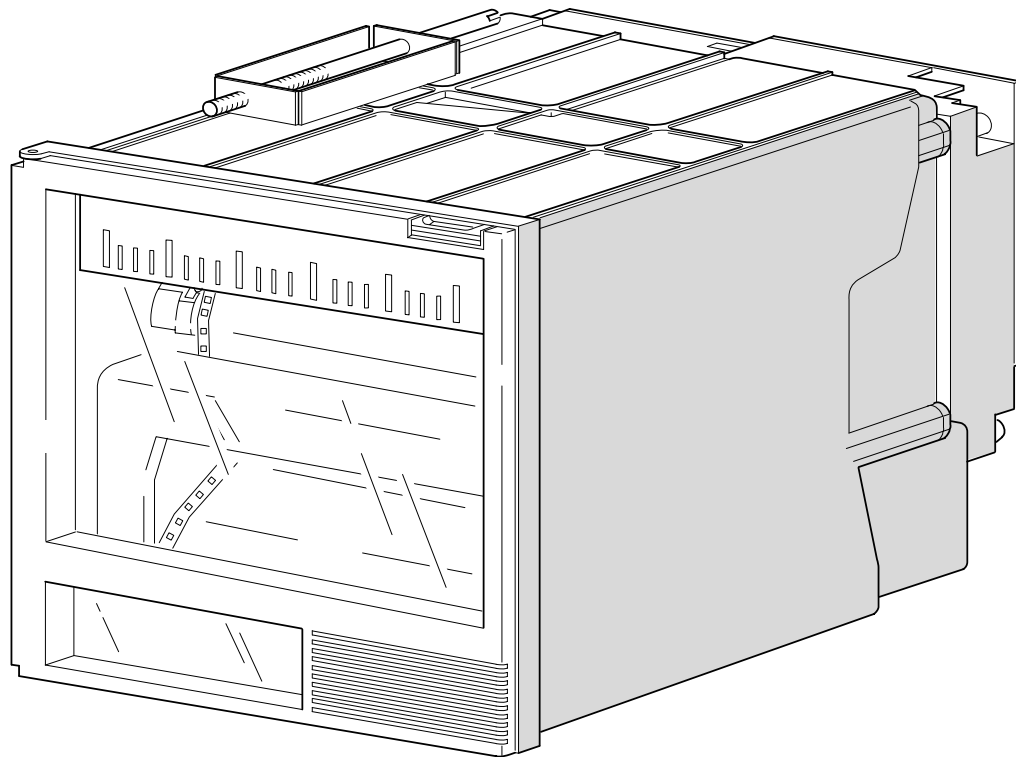

PREFACE

Congratulations on your purchase of Fuji Microjet Recorder (Type: PHE)

- Read this instruction manual carefully to ensure correct installation, operation and preparation. Incorrect handling may lead to accident or injury.
- Specifications of this unit is subject to change without prior notice for improvement.
- Modification of this unit without permission is strictly prohibited.
Fuji will not bear any responsibility for a trouble caused by such a modification.
- This instruction manual should be kept by the person who is actually using the unit.
- After reading the manual, be sure to keep it at a place easy to access.
- This instruction manual should be delivered to the end user without fail.

Manufacturer : Fuji Electric Co., Ltd.
Type : Shown on nameplate of Microjet recorder
Date of manufacture : Shown on nameplate of Microjet recorder
Product nationality : Japan

Request

- It is prohibited to transfer part or all of the manual without Fuji's permission.
- Description in this manual will be changed without prior notice.



© Fuji Electric Co., Ltd. 1999

Issued in November, 1999
Rev. 1st edition April, 2000



CAUTION ON SAFETY

First of all, read this “Caution on safety” before using the unit.

- The cautionary descriptions listed here contain important information about safety, so they should always be observed. Those safety precautions are ranked 2 levels, DANGER and CAUTION.

 DANGER	<p>Wrong handling may cause a dangerous situation, in which there is a risk of death or heavy injury.</p>
 CAUTION	<p>Wrong handling may invite a dangerous situation, in which there is a possibility of medium level trouble or slight injury or only physical damage is predictable.</p>
 PROHIBITION	<p>Items which must not be done are noted.</p>

Caution on Installation

 DANGER	<ul style="list-style-type: none"> • This unit is not an explosion-proof type. Do not use it in a place with explosive gases to prevent explosion, fire or other serious accident.
 CAUTION	<ul style="list-style-type: none"> • For installation, select a place observing the operating conditions noted in the instruction manual. Installation at an unsuited place may cause fall, trouble or malfunction. • The unit must be installed correctly as shown in the instruction manual. Incorrect installation may cause fall, trouble or malfunction. • During installation work, keep the inside of the unit free from entry of cable chips or other foreign objects as it may cause fire, trouble or malfunction.

 CAUTION	<p>This unit is a component device used for instrumentation. It is mounted on a panel or in a rack.</p> <ul style="list-style-type: none"> • The unit conforms to IEC1010-1 (1990) Safety Standards, and is designed for protection class I, overvoltage Category II and pollution degree 2, except the alarm output terminal (overvoltage category I). • EMC conforms to EN50081-1 (1992) and EN50082-1 (1992), (both used for housing areas), except that the noise level of the power terminal is rated for Class A (used for commercial and industrial areas). • Input signals and communication interface should be of SELV (safety separated from hazardous voltage).
--	--

Caution of Wiring



DANGER

- Wiring work must be performed as specified. If the unit is not earthed, it would result in electric shocks or malfunction.
- Be sure to connect power source that matches the rating. Connection of incorrect rating of power source may lead to fire.
- Before starting wiring work, be sure to turn OFF the main power to prevent electric shocks.
- Wiring materials to be used must meet the rating. Use of materials which do not withstand the rating may cause a fire accident.

Caution on Maintenance



DANGER

- When disposing of the recording head, put it in a vinyl bag and seal it to prevent the diffusion of ink. It should be handled as an imcombustible object when disposing of it.
- Ink is harmful to human body. Observe the following emergency treatments.
 - When ink gets in eyes, wash out for at least 5 minutes immediately with much clean water, and ask your doctor for treatment at once.
 - When ink gets on skin, wash out and clean skins with soap and water.
 - When ink is breathed in, move to a clean place immediately. If necessary, ask your doctor for treatment at once.
- Do not touch the connector at the rear of the carriage mounting the recording head to avoid the risk of electric shocks.

Caution on Use



DANGER

- If the fault or anomaly of the device may cause serious accident or troubles to other devices, externally install appropriate protective circuit to avoid accidents.
- The instrument has no power switch nor fuse. Install them if necessary.
- When fuse is blown out, check and remove the cause of it, and replace it with new one specified in the instruction manual. Do not use any other fuse or short it, as it may cause electric shocks or fire.

CONTENTS

PREFACE	i
CAUTION ON SAFETY	ii
1. INTRODUCTION	1-1
1.1 Microjet recorder	1-1
1.2 Product check	1-1
1.3 Check on type and specification	1-2
2. NAMES AND FUNCTIONS OF PARTS	2-1
3. MOUNTING METHOD	3-1
3.1 Mounting location	3-1
3.2 External dimensions and panel cut out dimensions	3-1
3.3 Method of mounting onto panel	3-2
4. WIRING	4-1
4.1 Before wiring	4-1
4.2 Caution on power source wiring	4-1
4.3 Connection to terminals	4-2
5. SET-UP	5-1
5.1 Loading chart paper	5-1
5.2 Recording head installation (replacement)	5-4
6. OPERATION AND ACTIONS	6-1
6.1 Before running the equipment:	6-1
6.2 Turning on power and status	6-2
6.3 Printing the test pattern	6-2
6.4 Operation in normal mode	6-3
6.5 Displays and print-outs on detection (cancellation) of alarms	6-4
6.6 Displays and print-outs on occurrence of burnt-out	6-4
6.7 Indication of over-range, under-range display and abnormal input display	6-5
6.8 Display of fault in recording head carriage	6-5
6.9 Display of skipped parameter	6-5



CAUTION

Chapter 3,4 and chapter 8 should be observed for installation and maintenance of the unit. So, it must be performed by qualified engineers.

7.	SETTING AND CHECKING PARAMETERS	7-1
7.1	Setting and Checking	7-1
7.2	Outline of procedure for setting parameters	7-2
7.3	Key lock setting/release	7-3
7.4	Setting the Chart Speed (main chart speed)	7-4
7.5	How to list	7-5
7.6	How to print the scale (manually)	7-6
7.7	How to set ON/OFF of periodic print-out	7-7
7.8	How to set ON/OFF of scale print-out	7-8
7.9	How to set the input filter	7-10
7.10	How to set the alarm	7-11
7.11	Selecting whether to start recording when turning on	7-13
7.12	Setting of date and time	7-14
8.	MAINTENANCE - INSPECTION	8-1
8.1	Maintenance/inspection items	8-1
8.2	Battery replacement procedure	8-2
9.	Adjustment mode	9-1
9.1	How to adjust the printing and recording (adjust the backlash)	9-1
9.2	How to position the analog trend recording (position the head zero/span)	9-2
9.3	How to set the PV shift	9-3
9.4	How to set the sub chart speed	9-5
9.5	How to set the skip	9-6
9.6	Head selection	9-7
9.7	How to calibrate measured value (ADJUST)	9-8
10.	TROUBLESHOOTING	10-1
11.	EXAMPLES OF RECORDING AND PRINTING	11-1
11.1	Periodic print-out and scale print-out	11-1
11.2	Digital print-out (Instantaneous values)	11-2
11.3	Parameter listing	11-2
11.4	Test pattern	11-3
11.5	Scale print-outs (manual print-outs)	11-3
11.6	Alarm print-outs	11-4
11.7	Burn-out print-out	11-4
11.8	Record start mark	11-4
11.9	Chart speed change mark	11-4
12.	SPECIFICATION	12-1
	APPENDIX 1. MOUNTING OF PHE OPTIONAL UNITS	A-1
	APPENDIX 2. SYSTEM PARAMETER SETTING	B-1
	APPENDIX 3. CHANGE OF HARDWARE	C-1

1. INTRODUCTION

We thank you for purchasing Microjet Recorder PHE.

The instruction manual describes installation, operation, maintenance, etc. of Microjet Recorder. Read it carefully before use.

1.1 Microjetrecorder

- ① This recorder (100mm wide) is used to record up to 6 points of input signals from a thermocouple, resistance bulb and DC voltage.
- ② Analog trend data and digital print data are color recorded clearly and quickly.
- ③ Analog trend data can be recorded continuously or intermittently (see Item 1.3 “Check on type and specification”).
- ④ Besides recording measured values, chart paper feed speed, measurement range, etc. can be printed as standard functions.

1.2 Productcheck

Upon receiving the unit, check the appearance and accessories to make sure that they are not damages. Also, check that the accessories are supplied correctly.

Check on accessories

The unit comes with the accessories shown in Fig. 1-1. Please check that they are all there.

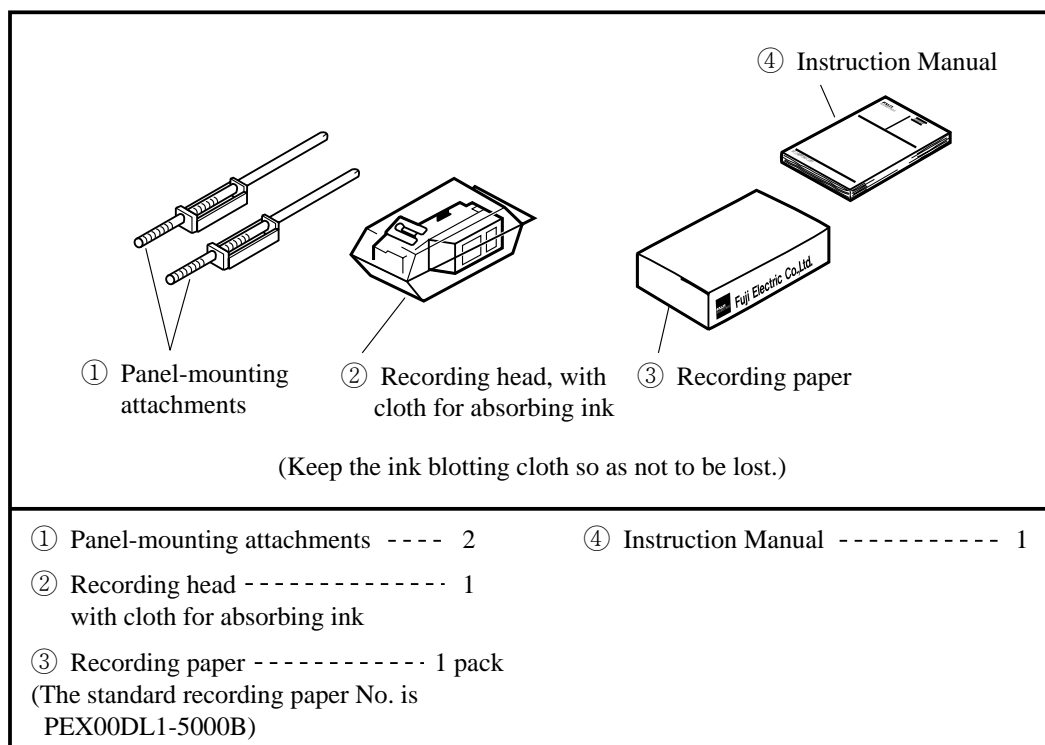
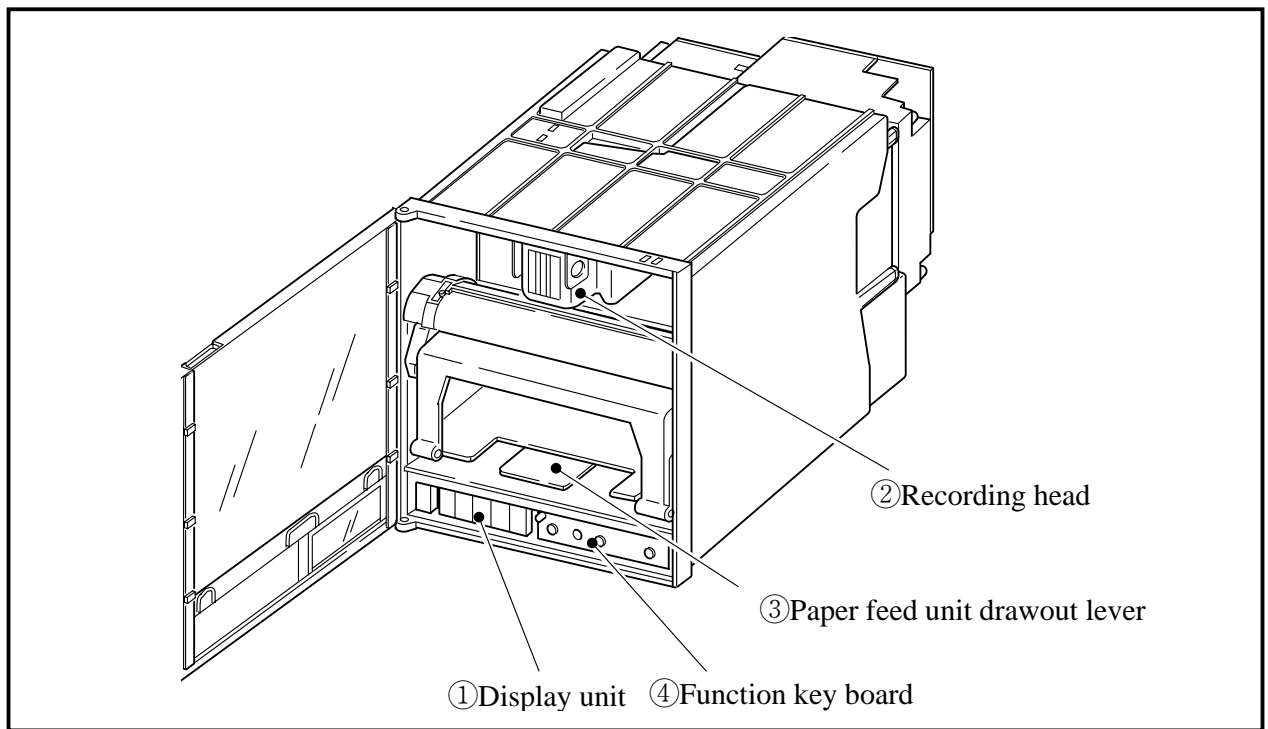

Fig. 1-1 Accessories

2. NAMES AND FUNCTIONS OF PARTS



(1) Display unit

Time, measurement data, set values and comments are displayed.

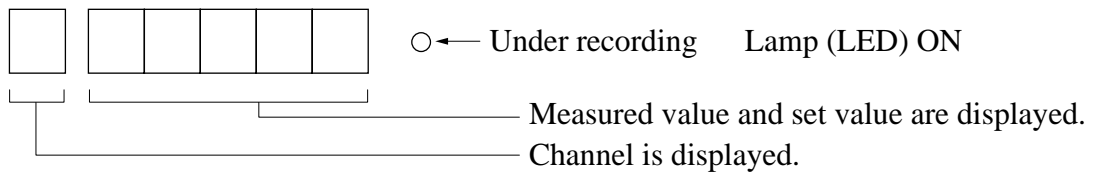

(2) Recording head

Used for analog trend recording and digital printing. **(Recording head is not mounted in the recorder prior delivery. It should be mounted referring to Item 5.2)**

(3) Paper feed unit drawout lever

When setting (replacing) chart paper, press down the drawout lever and the paper feed unit will be drawn out. If it is not drawn out automatically, pull out the paper feed unit by hand while pressing down the lever.

(4) Function key board

Used for setting or confirming parameters and for operating the recorder.

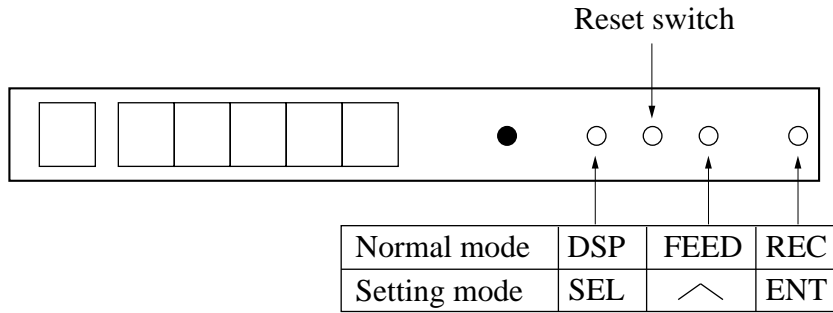

- Normal mode : Measured value or the states of alarm of each channel is displayed. This mode is started at power ON.
- Setting mode : This mode is used for setting chart speed or alarm.

	Name of key	Function
Normal mode	REC (record)	Recording start/stop function key. Recording is started at the first press of the key and stops at the second press.
	FEED (feed)	Chart paper fast feed key Feed speed becomes fast by pressing the key for more than 3 seconds.
	DSP (display)	1. Used for changing display data . The following 2 functions are selected at each press of the key. (1) Data of all channels are displayed in order, except for the skip channel. (2) Display only of the data of specific channels. 2. Used when shifting from normal mode to setting mode (press the key for more than 3 seconds)
Setting mode	ENT (entry)	Used to register set data and to start or stop list printing.
	 (up)	Used to change set data. Chart paper fast feed is effected during list printing.
	SEL (select)	1. Used to read parameters in order in setting mode. This key can not be used during list printing. 2. Used when shifting from setting mode to normal mode (press the key for more than 3 seconds)
	Reset switch	Used to reset the recorder (The operation is the same as that at power ON/OFF.)

3. MOUNTING METHOD

This unit is designed to be panel mounted.

3.1 Mounting location

Select the following location for mounting the unit.

- (1) A place that is not subject to vibration or shock.
- (2) A place where there is no corrosive gas.
- (3) A place that is subject to little temperature variation and is close to normal temperature (23°C)
- (4) A place that is not struck directly by strong radiant heat.
- (5) As humidity affects the ink and recording paper, select a place that is in the range 45 to 80% RH.
- (6) Mount the unit horizontally, with no tilt to the left or right.
(The forward tilt should be 0° but the unit may be inclined 0 to 30° rearwards.)

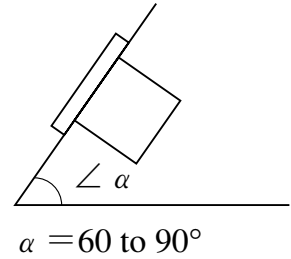

3.2 External dimensions and panel cutout dimensions (unit: mm)

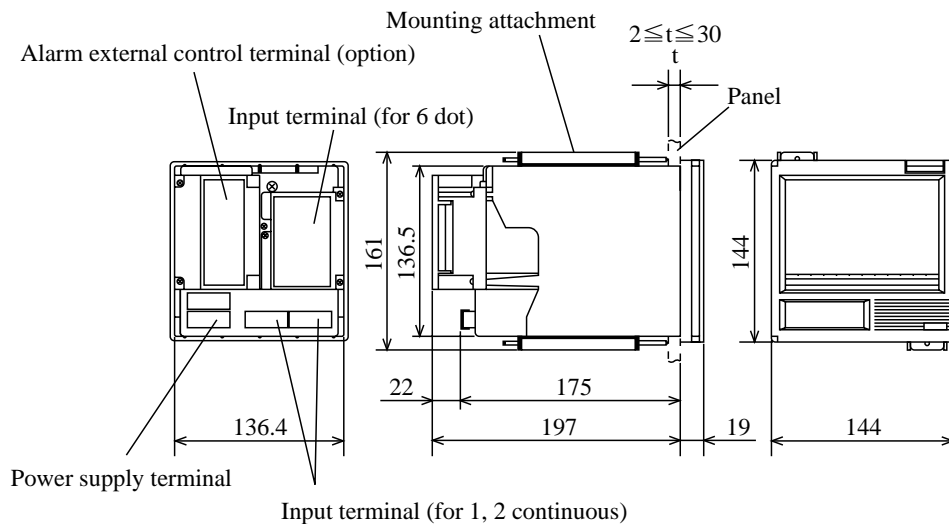

Number of units	$L + 1.5$ 0 (mm)
2	282
3	426
4	570
5	714
6	858
7	1002
8	1146
9	1290
10	1434
n	$(144 \times n) - 6$

- Mass : Continuous type Approx. 1.3kg
(without alarm terminal)
Approx. 1.5kg
(with alarm terminal)
- Intermittent type Approx. 1.5kg
(without alarm terminal)
Approx. 1.7kg
(with alarm terminal)

PANEL CUTOUT

For single unit mounting For left/right tight fit mounting

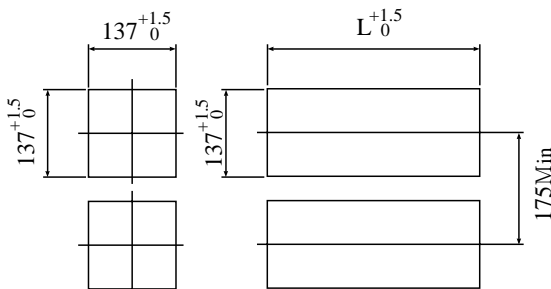

- Power consumption :
Approx. 13VA (100V AC, without option)
Approx. 15VA (100V AC, with all options)

3.3 Method of mounting onto panel

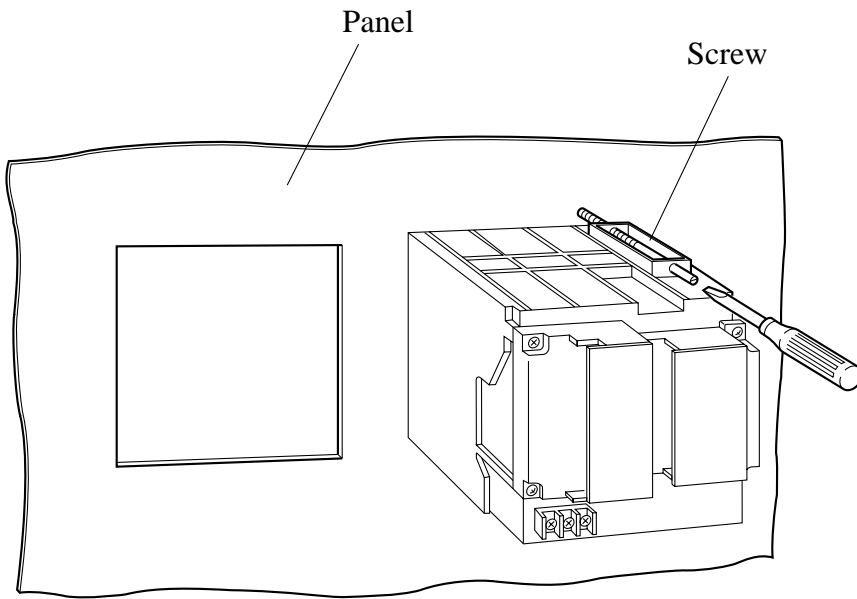

- Using the supplied mounting fixture, tighten the upper and lower screws until the panel is fixed.
- The panel to be used should be more than 2mm thick.

4. WIRING

4.1 Beforewiring

- ① For thermocouple input, be sure to use a compensated lead wire.
- ② Input signal cables should be wired separately as far as possible (30cm or more) from power lines and high-voltage lines to minimize the effect of inductive noise. Shielded cables should preferably be used. In this case, the shield braids should be earthed at one point.

Notes

- (1) At the completion of wiring of the input terminals, be sure to close the rear cover to ensure the compensation of reference contact when thermocouple input is used.
- (2) For connection of lead wires to terminals, use of sleeve-insulated clamping terminals (for M4 screws) is recommended.

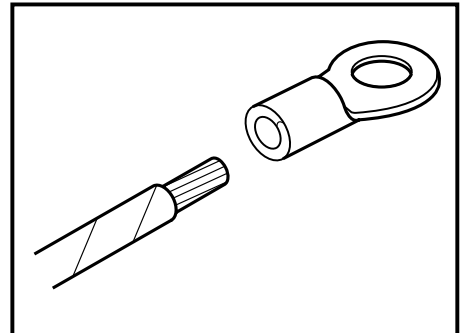

4.2 Caution on power source wiring

- ① This recorder has no power fuse. Mount a power fuse outside the recorder as necessary.
Recommend fuse rating : AC250V, 1A
- ② When connecting power cable and earth cable to terminals, be sure to use crimp style terminals with insulated sleeves (M4 screw).
- ③ For power cable connection, be sure to use 600V vinyl insulated cable or equivalent.



- Before making a wiring work, be sure to turn OFF the main power to prevent the risk of electric shocks. After wiring, be sure to close the cover.
- Wiring materials to be used must meet the rating. Use of materials which do not withstand the rating may cause a fire accident.
- Wiring work must be performed as specified. If the unit is not earthed, it would result in electric shocks or malfunction.



The recorder is not provided with a power fuse.
Use an external power fuse.
Rating : T1A, 250V AC or equivalent protection.

4.3 Connection to terminals

1, 2 continuous recording

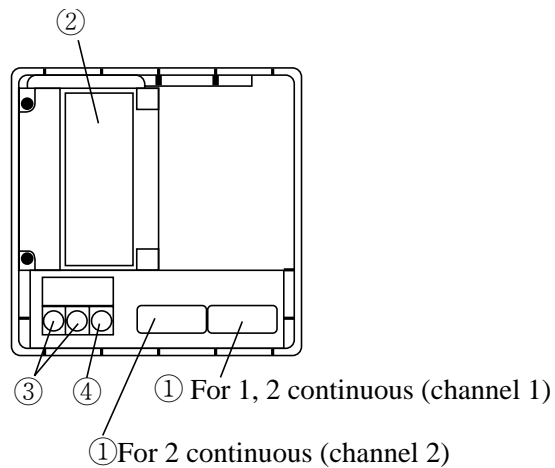

6 dot recording

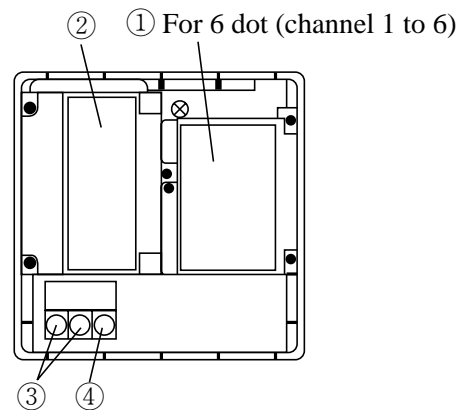

- ① Input terminal ⇒ Connect signal cable for each channel.
- ② Alarm/external control unit (option) ⇒ Connect the alarm signal output and external control signal input (for alarms 1 to 6, external control).
- ③ Power terminal ⇒ Connect power cable to **L****N** terminal. Power source to be connected should be free from noise .
(Code symbol : 100 to 120V AC or 200 to 240 V AC, 50/60 Hz)
- ④ Earth terminal ⇒ Connect to **PE** terminal (Class-3, less than 10 Ω).



Alarm output terminals (①① to ①⑥, ②① to ②⑥) are of overvoltage category I. Other terminals (input signals, communication interface) are for SELV signals (safety separated from hazardous voltage).

(1) Connection of input terminals

- ① Input terminal No. is determined for each channel.
- ② Connect input terminals according to the relation between the number of points of input signal and channel shown in Code Symbols (see Item 1.3).

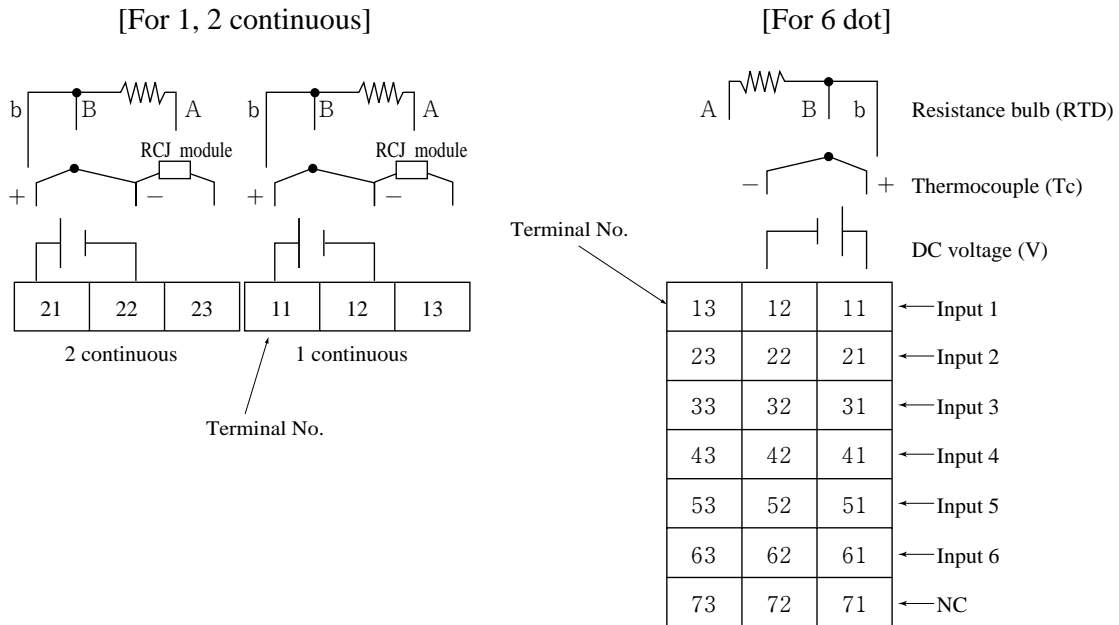



DANGER

· Before starting wiring work, be sure to turn OFF the main power to prevent the risk of electric shocks.

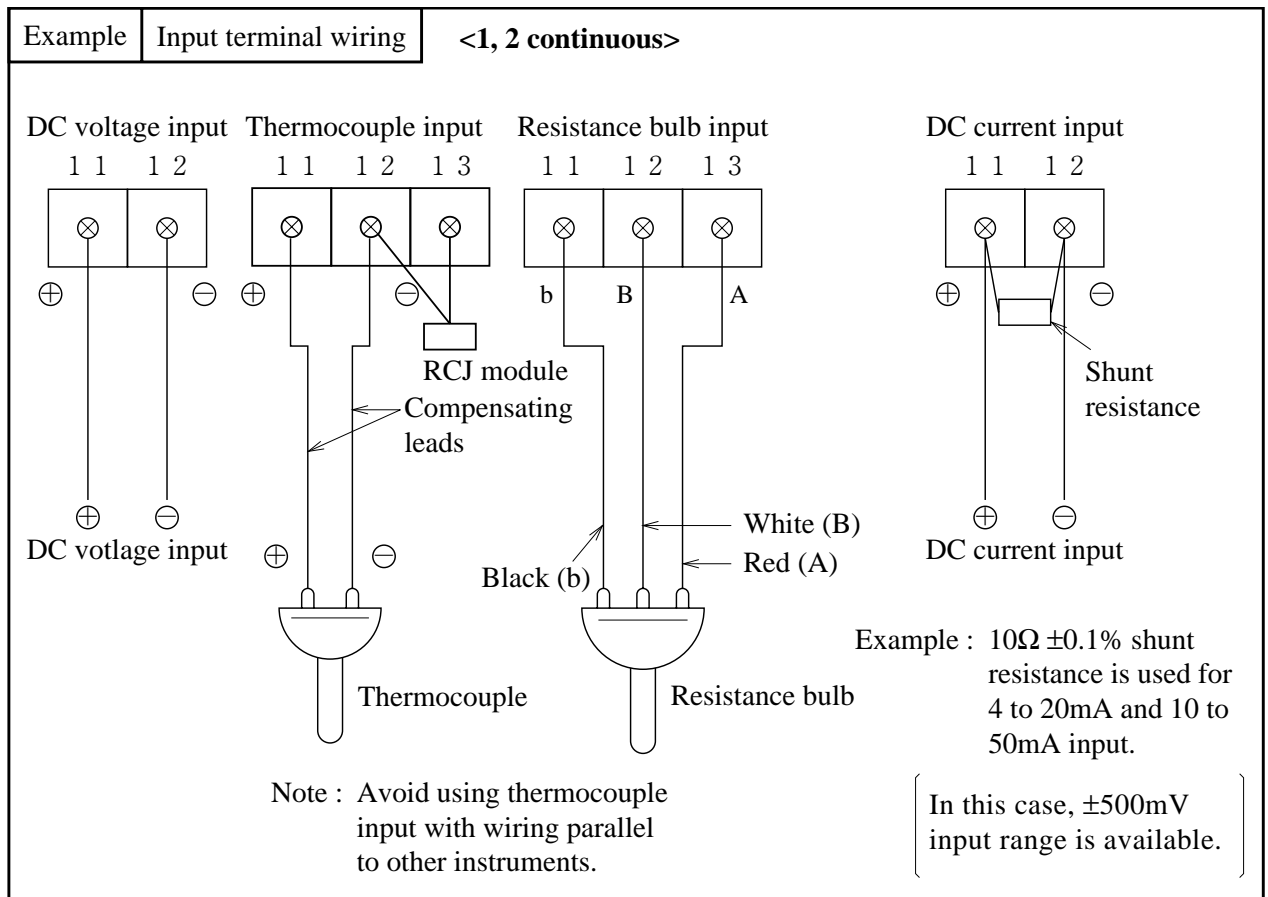

Example

Input terminal wiring

<6 dot>

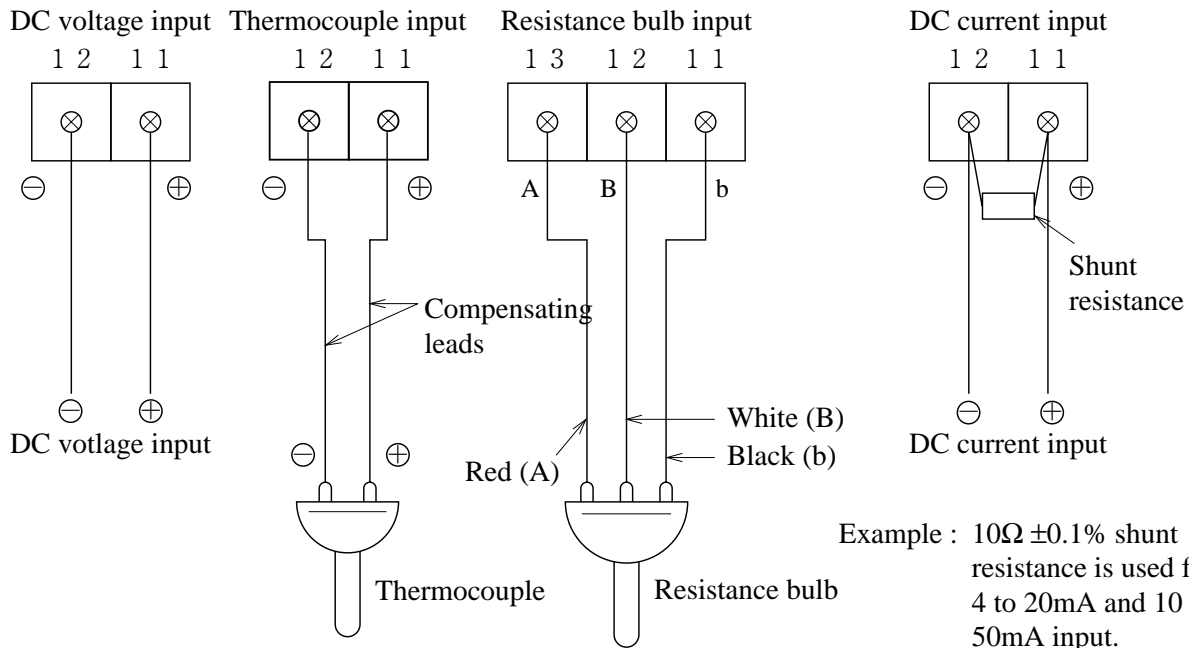

Example : $10\Omega \pm 0.1\%$ shunt resistance is used for 4 to 20mA and 10 to 50mA input.

Note : Avoid using thermocouple input with wiring parallel to other instruments.

Note : The line between channels is not insulated only at input from resistance bulb. Be sure to use an insulated type resistance bulb input unit.

In this case, $\pm 500\text{mV}$ input range is available.

(2) Alarm output/remote control unit (option)

About alarm outputs :

- ① Alarm setting (2 points) is provided for each input channel. Alarm output is option and selected from among 2 points, 4 points and 6 points.
- ② When an alarm is generated, the relevant terminals are shorted.
1a contact output : Relay contact capacity 240V AC/3A, 30V DC/3A (resistive load)
- ③ Alarm 1 to 6 corresponds to DO output No. 1 to 6 on the alarm setting panel. For details, refer to the alarm setting method under Item 7.10.

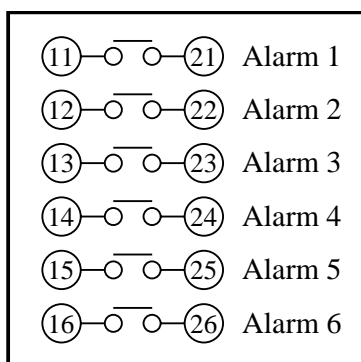

Note : If lamps are used on the outside, insert a resistor to prevent surge current.

Also, if relays or solenoids are used, insert elements for contact protection (diodes, surge killers, etc.).

External control unit

- ① This unit has a function “Chart speed selection” using contact signals from the outside of the recorder.
- ② Wiring

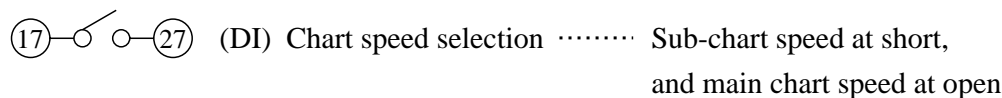

Note 1) The external control unit is not insulated and should be used with a relay connected to the outside.

External contact capacity : 12V DC/0.05A, 1a contact

Note 2) Recording start/stop operation is selected by setting sub-chart speed to 0 mm/h.

For details, refer to the sub-chart speed under Item 9.4.



- Before starting wiring work, be sure to turn OFF the main power to prevent the risk of electric shocks.

(3) Caution on connection of input signal through barrier

- A) Thermocouple input and resistance bulb input.

Perform "Calibration of measured value" with the input connected to the barrier recorder because the barrier internal resistance is added and causes an error in the measured value.

For the calibration method, refer to Item 9.7.

- B) When using Fuji Zener Barrier (PWZ), a power source 100V AC line (100 to 120V AC) should be used to ensure safe operation of the unit.

5. SET-UP

5.1 Loading chart paper

Step 1

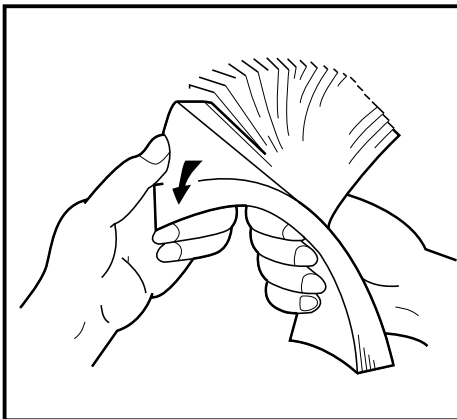

Prepare chart paper.
Loosen both ends of chart paper to avoid putting one on another before being fed into the recorder.

Step 2

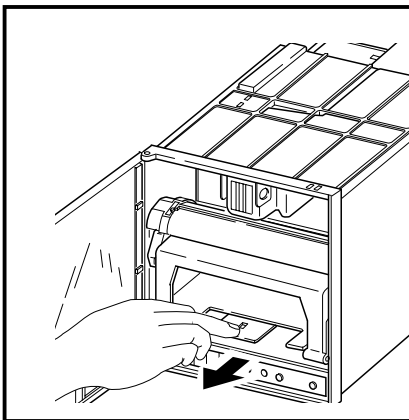

Open the front door and press down the paper feed unit drawout lever.
The paper feed unit will be drawn out.

Step 3

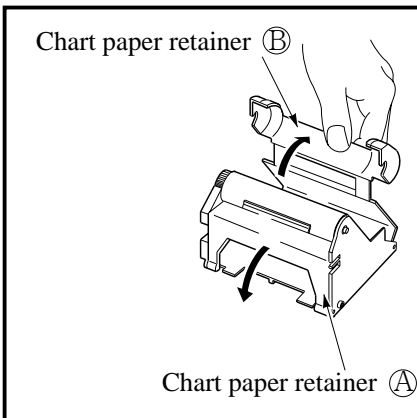

Hold the chart paper retainer **B** and open it backward.

Also, hold and open the chart paper retainer **A**.

Step 4

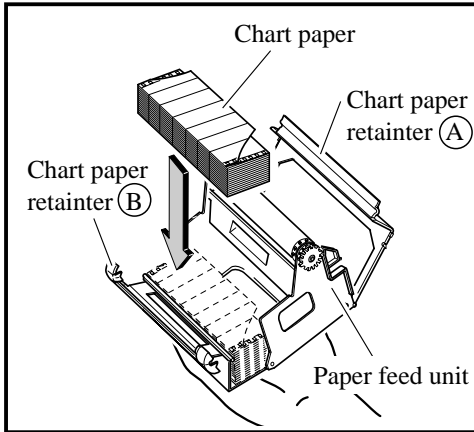

Set chart paper in the chart paper retainer (B) as illustrated.

Step 5

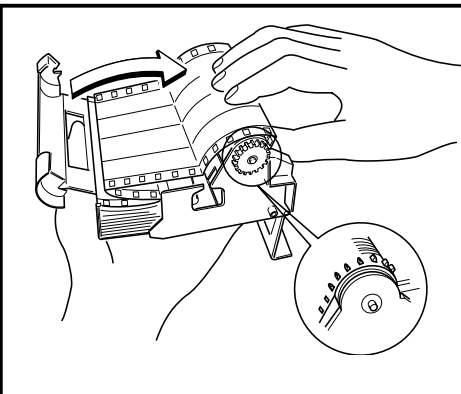

Insert the sprocket correctly in the perforations of chart paper. Move down the chart paper retainer (B) and set the paper on the roller unit.

At this time, make sure that both ends of the chart paper retainer (A) are locked securely.

Note) If some sheets of chart paper are folded and caught between the chart paper retainer (B) and the roller unit, set the paper once again.

Step 6

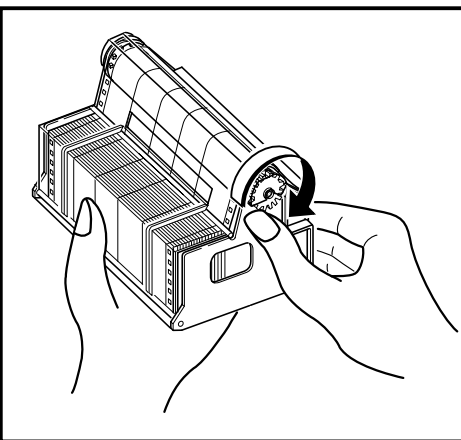

Shift the chart paper forward by turning clockwise the gear of the roller unit with hand.

Step 7

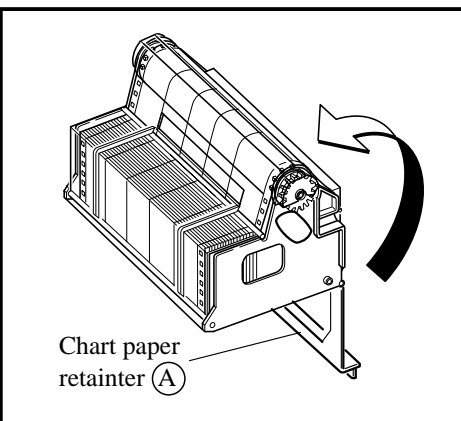

Transfer the chart paper which has been shifted forward, into the storage of the paper feed unit. Then set the chart paper retainer (A).

Step 8

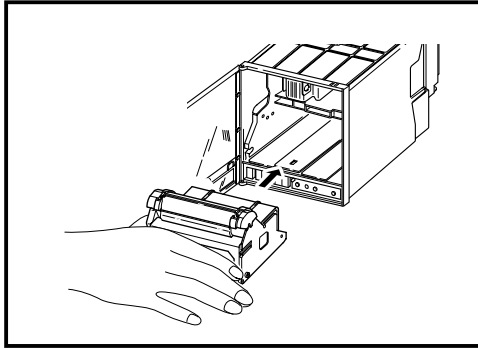

Mount the paper feed unit in the recorder. At this time, check that it is properly locked in position.

Step 9

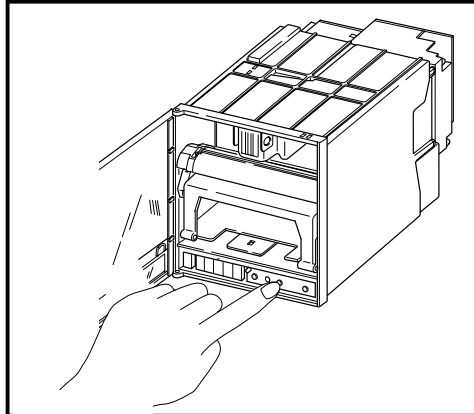

Press the **FEED** key and check that the chart paper is fed out smoothly.
(Feed out about 2 folds of paper.)
<If the paper is not fed out smoothly, go through the procedure from Step 2 again.>

Note 1 Selection of chart paper

The chart paper greatly affects the quality of the printed recording and it is also related to problems such as paper jamming, etc.

Please be sure to use the pure-quality chart paper specified us.

Chart paper type: PEX00DL1-5000B (50 equal divisions, no time lines).

Note 2 Use of the recorder after it has been left unused for a long time

If the recorder is left unused for a long time with chart paper still in the main unit, the paper 'packs down' and if the recorder is used straightway there can be problems of paper jamming, etc.

If you use the equipment after it has been left unused for a long time, first press the **FEED** key to feed out 2 to 3 folds of the paper.

Reference 1 Chart paper length

The chart paper is approximately 15m long. This permits about 31 days continuous print-out at a chart speed of 20mm/h.

Reference 2 Chart paper end mark

The remainder of chart paper is indicated by numerals on the right of paper (unit : 10cm). When it becomes small, a red band will appear on the right to indicate that the chart paper needs to be replaced with new one.

(Note) The recorder is not provided with a chart paper end sensor. When chart paper is used out, stop recording or replace the chart paper with new one.

5.2 Recording head installation(replacement)

The recording head is a combination of a head and ink.

When ink is used out or trouble arises with the head, it can easily be replaced.

Use the recording head carefully observing the “Caution” noted in the later paragraph.

Step 1

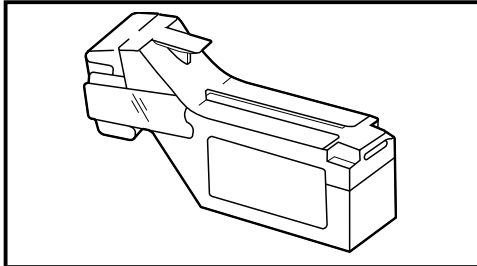

Get the recording head ready by taking it out of its aluminium pack.

Step 2

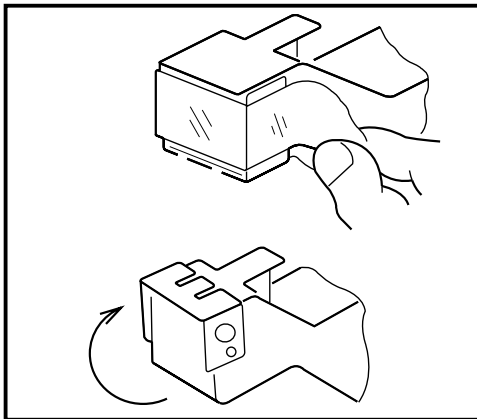

Tear the tape.

Open the cap by turning it in the direction indicated by the arrow.

(If the head is not going to be used for a long time, close the cap back in its original position.)

The cap is integral with the head unit. Turn it about 180° until it stops against the top of the head.

Step 3

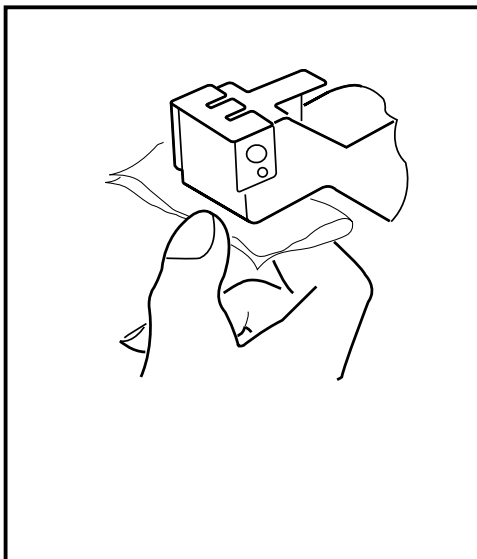

- Lightly attach **the supplied cloth to the nozzle** (ink ejecting side) to such up the ink. For the standard head, check to make sure that 4-color ink, blue, red, yellow and black, are soaked into the cloth (for the 2-color head, 2 colors of ink are soaked).

(First press the cloth against the surface for 2 to 3 second; if the 4 colors ooze out, it is OK.)

Note) Do not use any cloth other than the supplied one. Also, do not rub the nozzle with the cloth.

How to close the cap

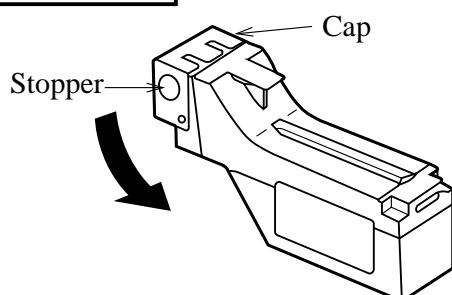

- Turn the cap in the direction indicated by the arrow and press it firmly until it is retained by the stopper.

- Ink may leak out if the cap is not properly in place.

Step 4

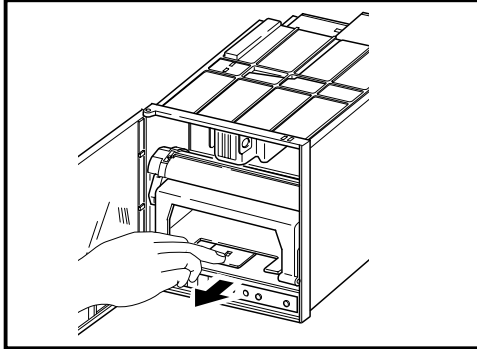

- Press the **REC** key. Operate the recorder after it has been set in recording stop mode.
- Open the front door and press down the paper feed unit drawout lever. The paper feed unit will be drawn out.

Step 5

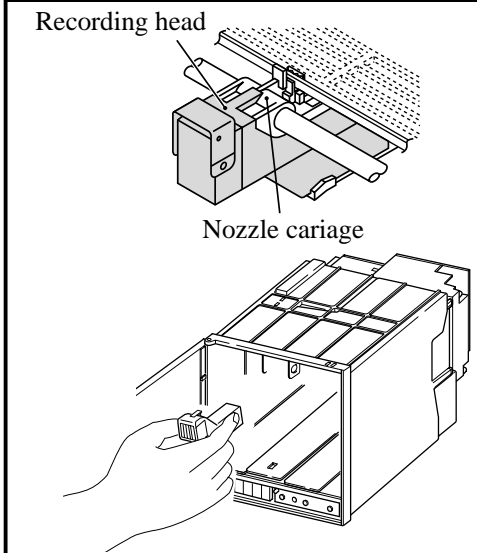

- Hold the recording head horizontally, **line it up with the carriage in the main unit, slide it in** slowly and press it firmly until it does not go in any further.
- Take care not to bang the nozzle surface of the head. Also, avoid touching the nozzle surface with your hand.



Do not touch the connector at the rear of the carriage to avoid the risk of minor electric shocks.

Step 6

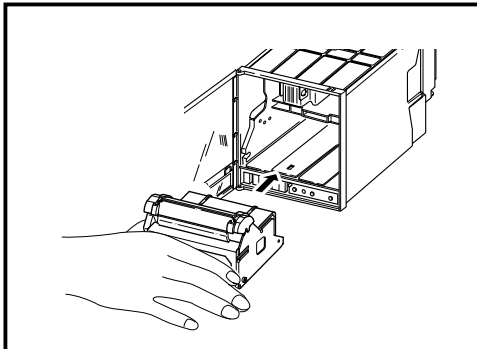

- Set the paper feed unit in its original position.

The above completes installation of the recording head.

The recording head is a consumable part. When the built-in ink is used out, replace the head with new one.

It comes in 2 types, one is for the 1, 2 continuous recording (PHZH2002) and another for the 6 dot recording (PHZH1002). Choose the type of the head according to the recording mode of the recorder.

Recording head replacement

Draw out the recording head in the manner that is opposite to what is described in **Step 5** of the recording head setting procedure, and replace it with a new recording head.

Always carry out the following procedure after replacing a recording head.

(1) Test pattern print-out

Print out a test pattern to check that normal recording is possible. See Section 6.3 for the way of printing out a test pattern.

(2) Adjustment of analog trend recording positions

Referring to Section 9.2, readjust the zero and span on the recording paper.

Precautions in handling recording heads

 DANGER	Handling recording heads
	<ul style="list-style-type: none">• Do not knock or shake recording heads as this can cause faults.• The inks are not harmful but they are very difficult to remove if they adhere to the skin or to clothes, so handle heads carefully in order to avoid staining. Also, do not disassemble them.• If, by accident, it happens that ink gets into your eyes, wash thoroughly with water as an emergency measure and then immediately consult a specialist doctor.• When the recording head is empty of ink, it should be disposed of as a incombustible object or returned to our office for reuse (recycling).

Note 1	If recording is halted and the recorder is not used for a long time
Carry out the following in order to prevent jamming and drying-up of the ink.	
<div style="border: 1px solid black; padding: 5px; width: fit-content; margin: 0 auto;">Remove the recording head from the main unit, make absolutely sure the cap is closed properly and store the head in a cool, dark place (average temperature 5 to 30°C).</div>	
If the head is left installed in the recorder:	
<div style="border: 1px solid black; padding: 5px; width: fit-content; margin: 0 auto;">Do not switch off the power to the recorder and do not close the cap. * Periodically, there is an automatic discharge of ink to prevent drying-up. Leave the recording paper in place in the recorder.</div>	
If it is not possible to keep the power switched on, make sure that the cap is closed. Draw out the paper feed unit using the recording head setting method (Step 4) . Open the indicator and tighten the cap.	

Note 2	At the start of use of a recording head
If you are starting to use a new recording head or if the recorder has been left unused for a long time, always wipe the head's nozzle surface lightly with the accessory cloth and check that the ink oozes out properly into the cloth. (See Step 3.) Also, after normal recording is possible. See Section 6.3 for the way of printing out a test pattern. When the working environment is 15°C or less, perform print-out of "test pattern" after period of several minutes has elapsed since the recording head was mounted. (The recording head has a built-in heater.)	

Note 3	Storage of recording heads
When they are delivered, recording heads are in aluminium packs. If you are not going to use a head straight-away, leave it sealed and store it in a cool, dark place with an average temperature of 5 to 30°C.	

Note 4	Shipping of recording head
--------	----------------------------

- Do not ship the unit recording head after the aluminum pack was opened up. If it is necessary to ship the unit recording head under avoidable circumstances, **be sure to close the cap**, and ship it as contained in a boxboard in the state where vibration and impact are eased using cushioning materials.
- **Always close the cap if you are transporting** a head while it is still installed in the recorder main unit.

Note 5	If the ink is not sprayed.
--------	----------------------------

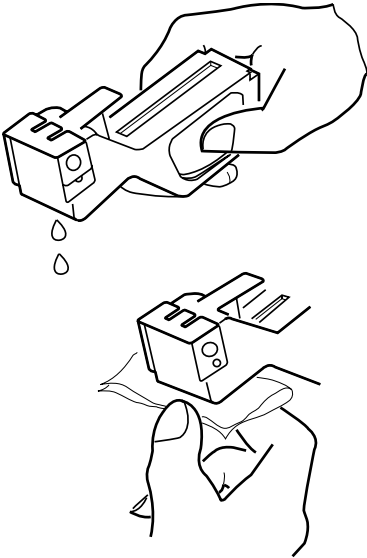

- ① Hold the recording head with turning the nozzle surface downward and push the side strong till spilling two drops.
- ② Absorb the standing ink on the nozzle surface with the cloth attached.
- ③ Hold the cloth to the nozzle surface again to find the ink flowed onto cloth.

When ink does not come out, repeat the above operation (① through ③).

* When working environment is 15°C or less, perform print-out of "record" or "test pattern" after a period or several minutes has elapsed since the recording head was mounted. (The recording head has a built-in heater.)

Reference	Ink consumption
-----------	-----------------

When recording at 20mm/h of chart speed and a given input, the consumption of ink is as shown below, though it depends on operating conditions.

- 1 continuous recording ----- about 20 months
- 2 continuous recording ----- about 12 months
- 6 dot recording ----- about 8 months

6. OPERATION AND ACTIONS

6.1 Before running the equipment:

Check the following points before starting operation.

1 Setting the chart paper and recording head

- ① Setting the chart paper See Section 5.1
- ② Setting the recording head See Section 5.2

2 Wiring

- ① Input terminals
 - ② Alarm terminals (option)
 - ③ Power and earth terminals
- } See Section 4.3

3 Conformity of input connection to recording channel

- ① Code symbols See Section 1.3

6.2 Turning on power and status

The instrument has no power switch. Engaging the power cord with power source turns it on.

1) Turning on power for the first time



The recording head slowly moves toward the left end (0% side).



After detecting the 0% position, the recording head moves to the approximate central position.

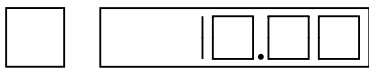

The current time appears on the display section, approximately 30 seconds later in case of 6 dot type.

2) Whether to start recording when turning on is as in “7.11 /Selecting whether to start recording when turning on”.



CAUTION

- Prior to delivery of the unit, the recording condition at power ON is set in “Record Stop” mode. When starting the recording operation at the time of recovery of power failure during operation, turn ON the power and set the unit in “Record Start” mode referring to Item 7-11.

6.3 Printing the test pattern

- ① Open the front door and press the **DSP** key for 3 seconds to display the following.



- ② Press the **SEL** key two times to display the following.



- ③ Press the **^** key until “0” turns “2”.

- ④ Press the **ENT** key to print the test pattern below.



Note 1) Make sure all colours are recorded. If any colour is not developed or is unclear, apply the furnished cloth carefully on the nozzle end to wipe it. (See 5.2, **Step 3.**)

Note 2) To quit print-out, press the **ENT** key again.

6.4 Operation in normal mode

(1) Stopping and starting the recording operation (REC key)

- Only in the normal mode, recording can be started or stopped.
- Each press of REC key alternately selects recording operation or recording stop.

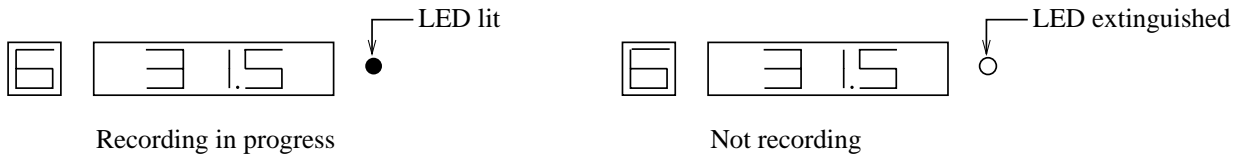

(2) Quick feed of recording chart (FEED key)

- Hold down the FEED key to quickly feed the recording chart, overriding the normal chart speed.

(3) Changing the display mode (DSP key)

- Pressing the DSP key changes the display mode.
- Each press of DSP key selects the next display mode.

(The number of screens depends on 1 continuous, 2 continuous or 6 dot recording.)

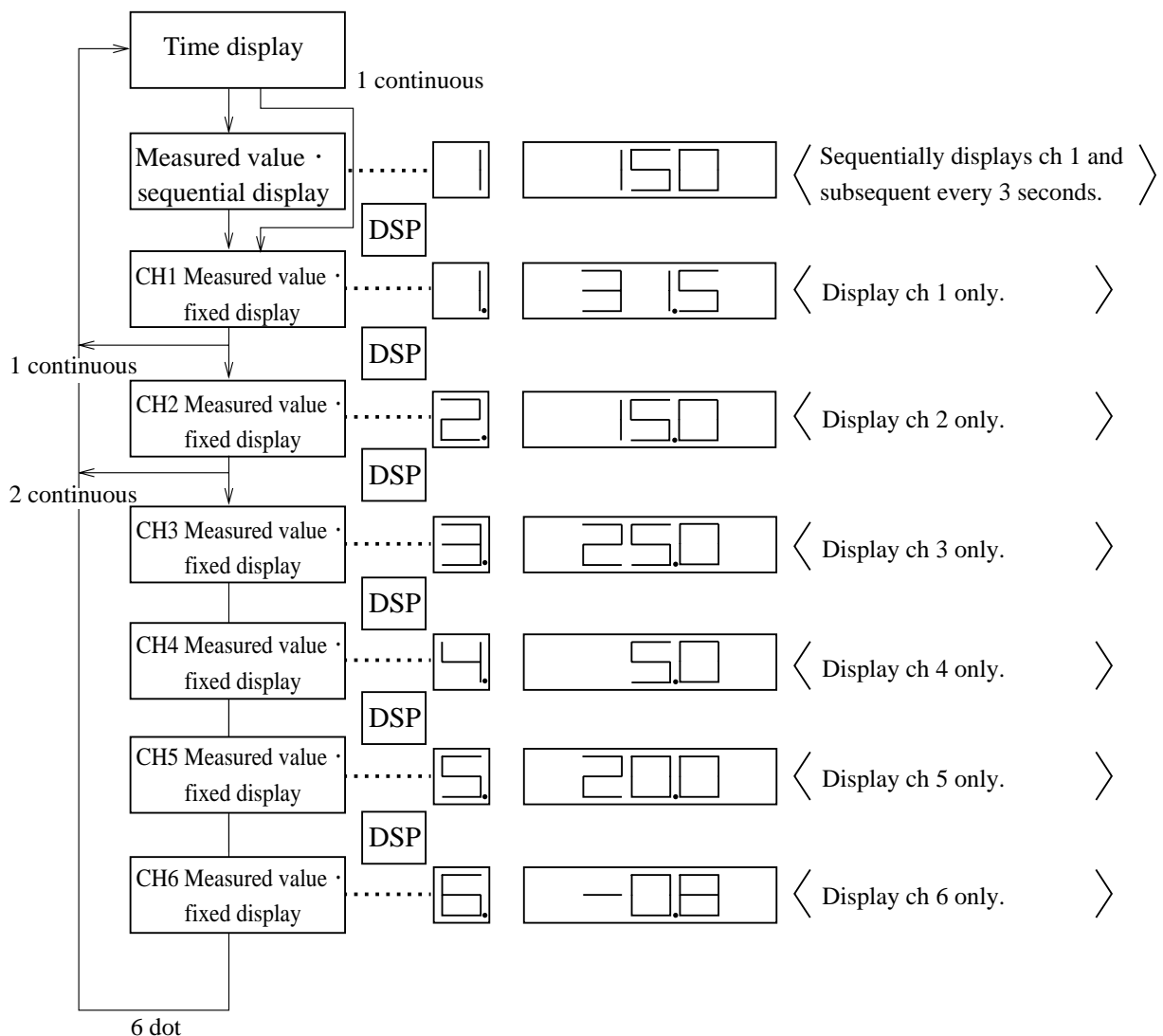

6.5 Displays and print-outs on detection (cancellation) of alarms

- ① When an alarm has occurred, its contents appear on the display section. They appear for 1 second every 3 seconds while displaying a measured value.

Note) In case of fixed display of measured value, the alarm status for the fixed channel only appears.

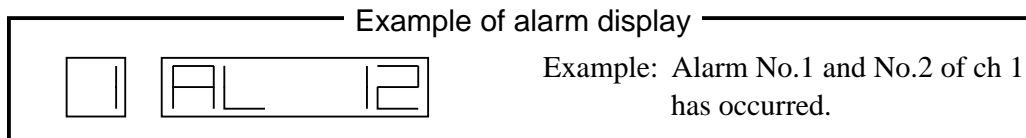

- ② When an alarm detected and cancelled, the relevant details are printed on the right-hand side of the chart paper.

On detection: The time of detection, channel No., type of alarm,
 ---- Print-out color: Red (6 dot), Red (1,2-continuous)

On cancellation: The time of cancellation, channel No., type of alarm
 ---- Print-out color: Black (6 dot), Blue (1,2-continuous)

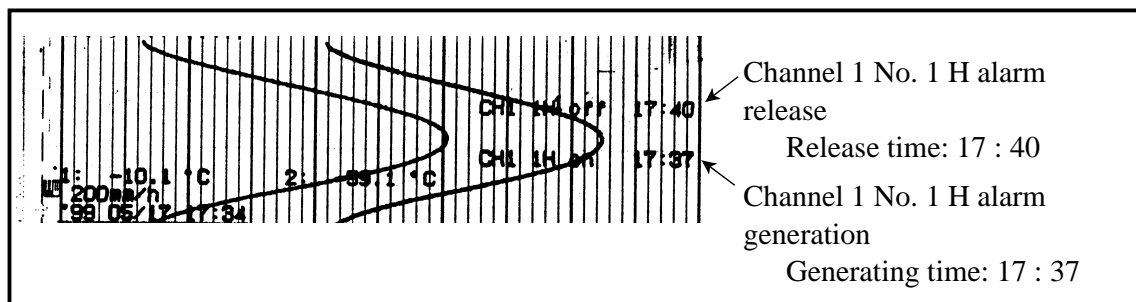

- ③ If an alarm is detected or a cancellation is made during data print-out or list print-out, the alarm print-out takes place after completion of the data or list print-out.
- ④ Up to a maximum of 30 alarm detection cancellation information can be stored and sequentially printed out, but if the storage capacity is exceeded because of a large number of detections/cancellations in a short time, information in the overflow portion is discarded and cannot be printed out.

6.6 Displays and print-outs on occurrence of burnt-out

- ① If a thermocouple or resistance bulb has burnt out, its contents appear.

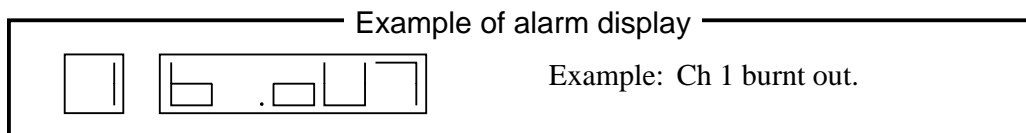

Note: Trend recording overswings toward the maximum side of the recording range.

- ② If a burn-out occurs, its contents are printed on the right of recording chart (in red).

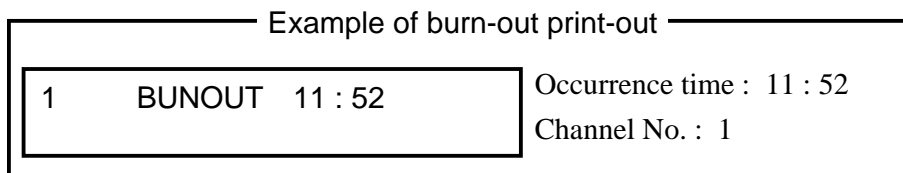

6.7 Indication of over-range, under-range display and abnormal input display

For any of thermocouple, resistance bulb and voltage inputs, the measurable input signal range is fixed. If the input is beyond the specified range, “over” or “under” appears.

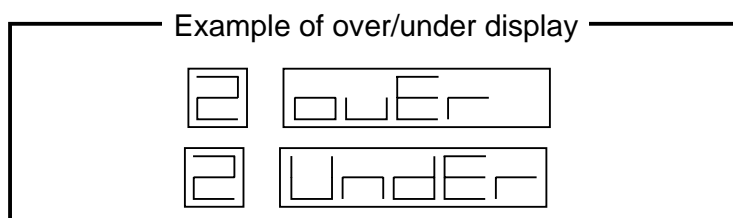

An input error indication appears if the voltage input signal line has been open-circuited or if the voltage input signal is further beyond over/under.

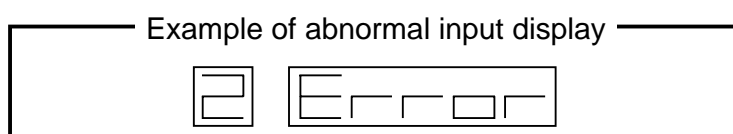

6.8 Display of fault in recording head carriage

If the recording head does not operate properly any more because the recording head running section is erroneous, an error appears and the recording operation stops.

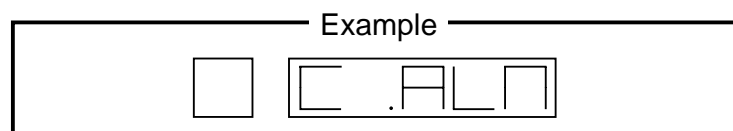

If "C. ALM" has appeared, turn OFF power and check the following points.

- (1) Check whether the recording head running shaft is clogged with foreign matters? (If contaminated, wipe off by dry rag.)
- (2) Check whether the recording head drive belt is cut or loose?
- (3) Check whether the recording chart floats, thereby touching the recording head?
- (4) Check whether the recording head is correctly installed?

After eliminating the cause of error, turn on the instrument again.

6.9 Display of skipped parameter

The channel for which the parameter setting is skipped appears as “ — — — ” on the display section. In the case, recording alarm and operations are not carried out at all.

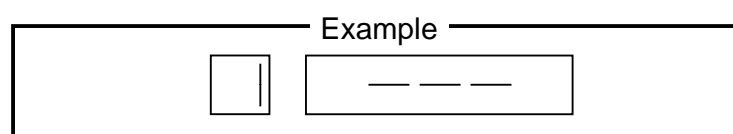

7. SETTING AND CHECKING PARAMETERS

7.1 Setting and Checking

- ① Parameters are factory set as given in the table below. Turning on power as they are initiates operation (indication, analog trend recording). As required, change the parameter setting.
- ② Alarm and PV shift are not set. Set them as necessary. Note that the input filter is set at 3 seconds.

Note) Before setting any parameter, install the recording chart.

(1) Parameters as set by factory (initial values)

Parameter name	Factory setting (initial values)	Remarks	How to check setting
Key lock	OFF (0)	Set to "1" for key lock	Item 7.3
Main chart speed	20mm/h	Settable range : 10,20,24,30,50,120,200 300,400,1000,1200,1500	Item 7.4
Periodic print-out	ON (1)	Set to "1" for periodic print-out	Item 7.7
Scale print-out	ON (1)	Set to "1" for scale print-out	Item 7.8
Input filter	3 seconds	Settable range:0 to 255 for each channel	Item 7.9
Alarm	—————	Alarm No.1 and 2	Item 7.10
	Alarm type : N	No alarm : N H alarm : H L alarm : L	
	at H, L	DO output No.: 0 0 : No DO output	
	Alarm set value : 0	To alarm setting range of each kind of input.	
Whether to start recording when turning on	Recording stop (0)	Set to "1" for getting ready to record when turning on . Set to "0" for record stop when turning on .	Item 7.11

7.2 Outline of procedure for setting parameters

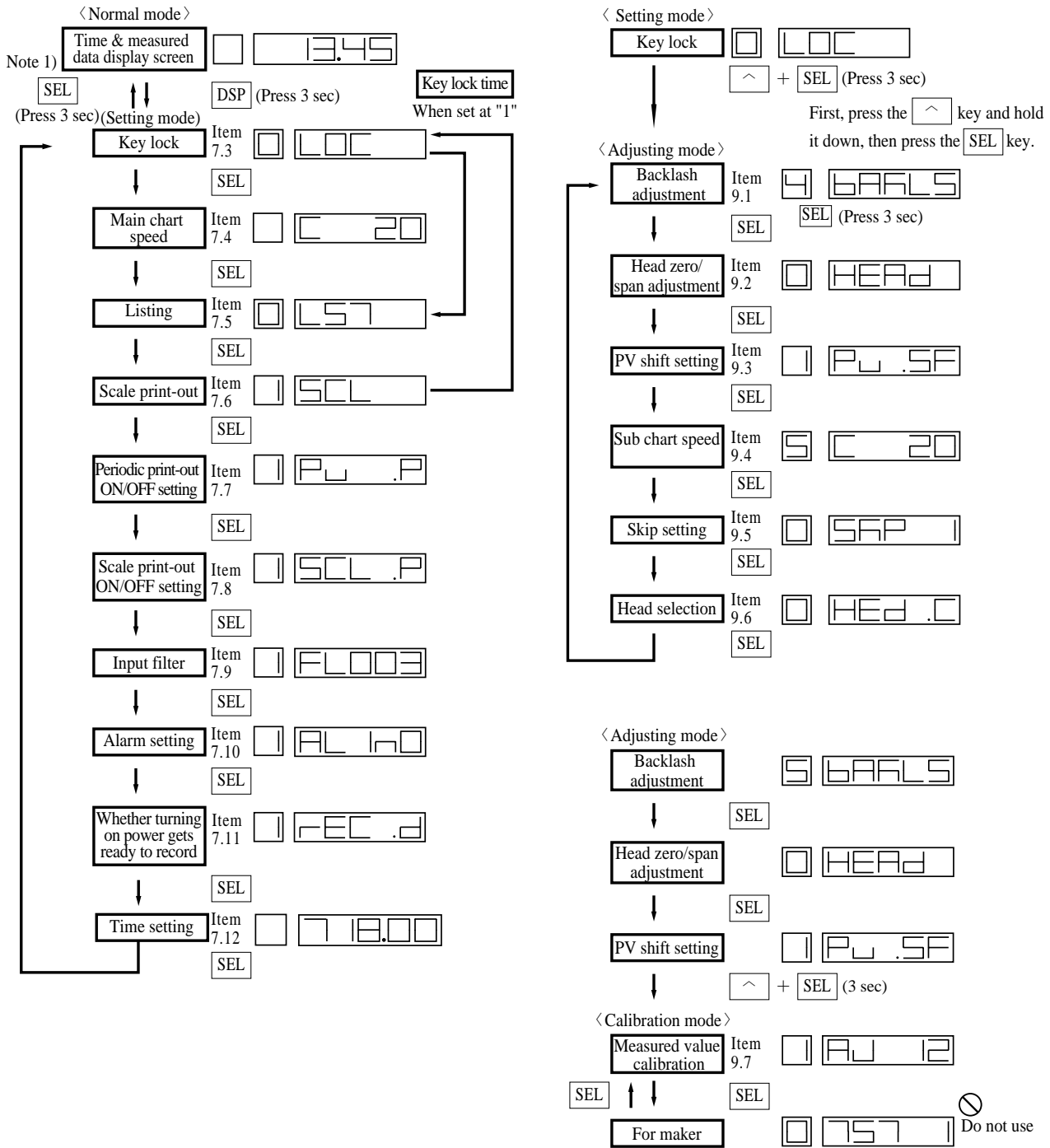











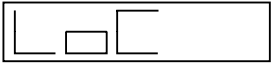

Note 1) By pressing the "SEL" key for 3 seconds on any mode (setting mode, adjustment mode and calibration mode), the screen returns to the normal mode.





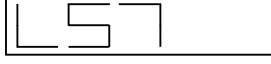





7.3 Keylocksetting/release

Explanation

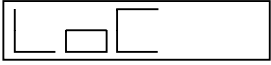
When parameters need not be changed after setting, you are advised to lock the key to prevent them from being changed accidentally. When the key is locked, the **SEL** key is used only for display of list printing and scale printing.

Key lock ON	1
Key lock OFF	0

Operation contents (ex.)		Lock the key.	
Keying	Explanation	Display	
DSP 	Press the DSP key for 3 seconds to select the setting mode. (key lock display appears.)		
\wedge 	Press the \wedge key until "1" is selected.		
ENT 	Press the ENT key to register and transfer to display of the next parameter.		
SEL 	Press the SEL key for 3 seconds to select the normal mode.		

Operation contents (ex.)		Unlock the keys.	
Keying	Explanation	Display	
DSP 	Press the DSP key for 3 seconds to select the setting mode. (key lock display appears.)		
\wedge 	Press the \wedge key until "0" is selected.		
ENT 	Press the ENT key to register and transfer to the next parameter display.		
SEL 	Press the SEL key for 3 seconds for setting in normal mode.		

7.4 Setting the Chart Speed (main chart speed)

Explanation

- Main chart speed : Set the recording chart speed in normal operation to one of 10, 20, 24, 30, 50, 120, 200, 300, 400, 1000, 1200 and 1500.
- If the case of a continuous recording type, if the chart speed is too fast, the result is dashed line recording instead of continuous recording. (As a general criterion, 1000mm/h or more)
- On a dot recording type, if the chart speed is fast, it becomes difficult to read recording due to increase in the space between break points. It is recommended that the recorder be used at a speed of 50mm/h or less.
- On a continuous recording type, the recording cycle varies with chart speed.













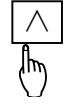

$$\text{Recording cycle(sec.)} = \frac{400}{\text{Chart speed (mm/h)}}$$

(But not faster than 2 seconds.)

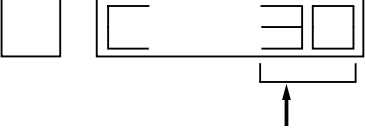
Example)

Chart speed (mm/h)	10	20	30	50	120	200
Recording cycle (sec.)	40	20	13 or 14	8	3 or 4	2

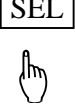
- The recording cycle for dot recording type is 30 seconds fixed.

Operation contents (ex.)	Changing the normal recording chart speed from 20 to 30mm/h.	
Keying	Explanation	Display
	Press the  key for 3 seconds to display the setting mode. (key lock display appears.)	 
	Press the  key to display the main chart speed.	
	Press the  key for selecting "30".	
	Press the  key to register and transfer display of next parameter.	
	Press the  key for 3 seconds for setting in normal mode.	













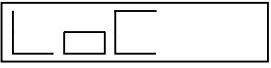

7.5 Howto list

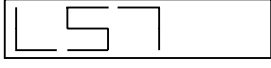
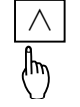
Explanation

- Use for arbitrarily printing the parameter list, instantaneous value list, test pattern or scale.

Listing	Print-out contents	Set value
Instantaneous value listing	Each channel measured value (instantaneous value) and engineering unit, time, channel number	0
Parameter listing	Input signal, input range, recording range, unit, alarm, input filter, chart speed, etc.	1
Test pattern print-out	Colour patterns and test characters	2
Scale print-out	Scale of desired channel (Refer to 7.6)	Next screen

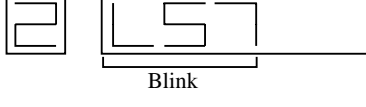
- Analog trend recording is stopped by listing but is automatically resumed after end of listing.

Operation contents (ex.)	Print a test pattern.	
Keying	Explanation	Display
	Press the  key for 3 seconds to display the setting mode. (key lock display appears.)	 
	Press the  key twice for displaying the listing.	 
	Press the  key for selecting "2" Test pattern.	
	Press the  key to start printing. [To stop printing, press the  key again. Pressing the  key while listing rapidly feeds the chart paper.]	
	After completion of printing, press the  key for 3 seconds for setting in normal mode.	

- Instantaneous value list ----- For print-out example, refer to 11.2.
- Parameter list ----- For print-out example, refer to 11.3.
- Test pattern ----- For print-out example, refer to 11.4.

Note 1) When resuming the analog trend recording after the end of listing in case of continuous recording type, the input values preceding and following the listing are recorded as continuous line.











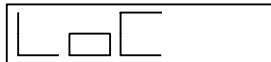

7.6 How to print the scale (manually)

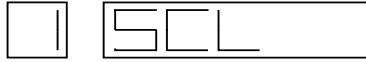
Explanation

- Use for arbitrary scale print-out.

Number of recording point	Settable range
1 continuous	1
2 continuous	1 to 2
6 dot	1 to 6

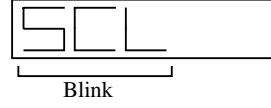
- Scale can be printed even while recording.
- Analog trend recording is stopped by scale print-out but is automatically resumed after the end of listing.

Operation contents (ex.)	Print 2 continuous type 2 ch scale.	
Keying	Explanation	Display
<div style="border: 1px solid black; padding: 2px; display: inline-block;">DSP</div> 	Press the <div style="border: 1px solid black; padding: 2px; display: inline-block;">DSP</div> key for 3 seconds to display the setting mode. (key lock display appears.)	 
<div style="border: 1px solid black; padding: 2px; display: inline-block;">SEL</div> 	Press the <div style="border: 1px solid black; padding: 2px; display: inline-block;">SEL</div> key three times for displaying the scale print-out.	
<div style="border: 1px solid black; padding: 2px; display: inline-block;">^</div> 	Press the <div style="border: 1px solid black; padding: 2px; display: inline-block;">^</div> key for selecting "2" (2 ch).	 
<div style="border: 1px solid black; padding: 2px; display: inline-block;">ENT</div> 	Press the <div style="border: 1px solid black; padding: 2px; display: inline-block;">ENT</div> key to start printing. [To stop printing, press the <div style="border: 1px solid black; padding: 2px; display: inline-block;">ENT</div> key again. Pressing the <div style="border: 1px solid black; padding: 2px; display: inline-block;">^</div> key while listing rapidly feeds the chart paper.]	 
<div style="border: 1px solid black; padding: 2px; display: inline-block;">SEL</div> 	After completion of printing, press the <div style="border: 1px solid black; padding: 2px; display: inline-block;">SEL</div> key for 3 seconds for setting in normal mode.	

*Scale print-out----- For print-out example, refer to 11.5.















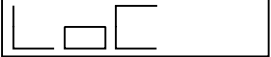



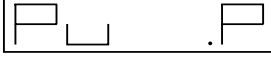

7.7 How to set ON/OFF of periodic print-out

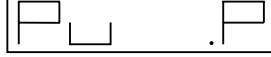
Explanation

- Selects whether or not to print the instantaneous values at fixed intervals while recording.
- Prints the following items at fixed intervals according to the chart speed.
[Printing start line, channel No., measured value, unit, chart speed, current time]
- Alternately selects periodic print-out and scale print-out.

Periodic print-out ON	1
Periodic print-out OFF	0

- For details, refer to "Relation between chart speed and printing" in Item 7.8.

Operation contents (ex.)	Periodic print-out (ON).	
Keying	Explanation	Display
 	Press the  key for 3 seconds to display the setting mode. (key lock display appears.)	 
 	Press the  key four times for displaying ON/OFF of periodic print-out.	 
 	Press the  key for selecting "1".	  ↑
 	Press the  key to register and transfer to the next parameter display.	 
 	Press the  key for 3 seconds for setting in normal mode.	













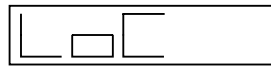

7.8 How to set ON/OFF of scale print-out

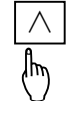
Explanation

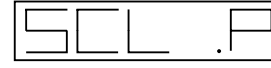
- Selects whether or not to print the scale while recording.
- The scale print-out for each channel sequentially is effected alternately with periodic print-out.
- The printing interval is automatically determined by chart feed speed.

Scale print-out ON	1
Scale print-out OFF	0

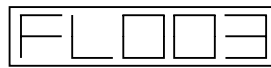
- For details, refer to "Relation between chart speed and printing" on Page 7-9.

Operation contents (ex.)	Scale print-out (ON).	
Keying	Explanation	Display
	Press the  key for 3 seconds to display the setting mode. (key lock display appears.)	 
	Press the  key five times for displaying the scale print-out.	 
	Press the  key for selecting "1".	  
	Press the  key to register and transfer to the next parameter display.	 
	Press the  key for 3 seconds for setting in normal mode.	

Relationship between chart speed and printing

- The following items depend on the recording chart speed.
 - ① Printing action : Provided that the printing is available, periodic print-out, scale, alarm, burn-out or channel No. digital print-out is available while recording.
 - ② Periodic print-out, scale print-out cycle : Print-out interval is determined by the chart speed. Periodic print-outs and scale print-out are effected alternately.
 - ③ Recording cycle : 1 continuous or 2 continuous recording cycles are determined by the chart speed. 6 dot recording cycle is 30 seconds fixed regardless of the chart speed.

Chart speed	1, 2 continuous recording			6 dot recording		
	① Printing action	② Periodic print-out cycle	③ Recording cycle	① Printing action	② Periodic print-out cycle	③ Recording cycle
10mm/h	Printable	8 h	40 sec.	Printable	8 h	30 sec. fixed
20mm/h		4 h	20 sec.		4 h	
24mm/h		4 h	16 or 17 sec.		4 h	
30mm/h		4 h	13 or 14 sec.		4 h	
50mm/h		2 h	8 sec.		2 h	
120mm/h		1 h	3 or 4 sec.	Unprintable	1 h	
200mm/h		30 min	2 sec.		30 min	
300mm/h		20 min	2 or 3 sec.		20 min	
400mm/h		20 min	2 sec.		20 min	
1000mm/h		6 min	2 sec.		6 min	
1200mm/h	Unprintable	6 min	2 sec.	6 min		
1500mm/h		4 min	2 or 3 sec.	4 min		

Note 1) Digital print-out is not made if 1, 2 continuous version has 1000 mm/h or higher chart speed.

Only printing start line is recorded.

Note 2) Digital print-out is not made if 6 dot version has 120 mm/h or higher chart speed. **Only**















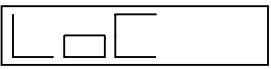



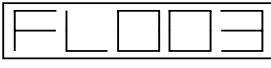



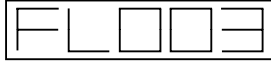



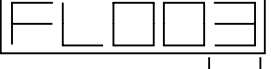

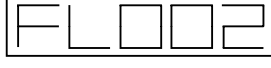

printing start line is recorded.

Note 3) Periodic print-out or scale print-out is not executed even if their time has come if listing is being executed then. Similarly, the periodic print-out or scale print-out being executed is stopped if listing is activated then, and the print-out is not recovered even after the end of listing.

7.9 How to set the input filter

Explanation

- Sets the input filter (time constant) for each channel.
- Settable in 1 second steps within the range of 0 to 255 seconds.

Operation contents (ex.)	Change the time constant of channel 2 from 3 to 2.	
Keying	Explanation	Display
 	Press the  key for 3 seconds to display the setting mode. (key lock display appears.)	 
 	Press the  key six times for displaying the input filter setting.	 
 	Press the  key to change the channel 1 to channel 2.	 
 	Press the  key 3 times to blink 1-place.	 
 	Press the  key several times for changing 3 to 2.	 
 	Press the  key to register.	 
 	Press the  key for 3 seconds for setting in normal mode.	 

7.10 How to set the alarm

Explanation

- Channel : Setting of channel No. for object alarm.
- Alarm No. : Up to 2 alarms can be set per channel.
- Kind of alarm : 2 kinds, H and L (settable freely for each alarm).
N selected delivers no alarm (gives no alarm display nor alarm output).
- Alarm set value : Setting in engineering values (see Table 1 Alarm settable range).
- DO output No. : Setting of option alarm unit relay No. (0 to 6, no output at 0).
DO output can also be used for common setting (OR output).

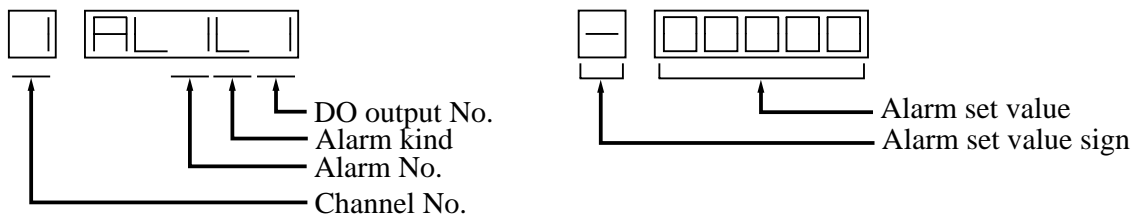

Note 1) Set the sign concurrently with digit 5. (Refer to the next page)

Note 2) Blank for plus or " - " for minus.

Operation contents (ex.)	Change the alarm No. 1 for channel 1. N → H 0.0°C → 80.0°C DO0 → 2	
Keying	Explanation	Display
 	Press the key for 3 seconds to display the setting mode. (key lock display appears.)	
 	Press the key seven times for displaying the alarm setting.	
 	Press the key until a channel to change is selected and press the key.	
 	Press the key until an alarm No. to change is selected and press the key.	
 	Press the key until "N" turns "H" and press the key.	

Keying	Explanation	Display
	Press the key until "0" turns "2".	
	Press the key to display the alarm set value.	
	Press the key twice for blinking the 10-places.	
	Press the key for turning "0" to "8".	
	Press the key three times for displaying the alarm setting. The set value is registered.	
	Press the key for 3 seconds for setting in normal mode.	

Table 1 : Alarm settable range

Kind		Alarm settable range	
Thermocouple	B	370.0 to 1790.0°C	698.0 to 3254.0°F
	R	- 30.0 to 1790.0°C	- 22.0 to 3254.0°F
	S	- 30.0 to 1790.0°C	- 22.0 to 3254.0°F
	K	-230.0 to 1400.0°C	-382.0 to 2552.0°F
	E	-230.0 to 830.0°C	-382.0 to 1526.0°F
	J	-230.0 to 1130.0°C	-382.0 to 2066.0°F
	T	-230.0 to 430.0°C	-382.0 to 806.0°F
	N	- 30.0 to 1330.0°C	- 22.0 to 2426.0°F
	W	- 30.0 to 1790.0°C	- 22.0 to 3254.0°F
	L	-230.0 to 930.0°C	-382.0 to 1706.0°F
U	-230.0 to 430.0°C	-382.0 to 806.0°F	
P N	- 30.0 to 1330.0°C	- 22.0 to 2426.0°F	
Resistance bulb	JPt100	-230.0 to 630.0°C	-382.0 to 1166.0°F
	Pt100	-230.0 to 630.0°C	-382.0 to 1166.0°F
DC voltage scalling OFF		-55.00 to 55.00mV -550.0 to 550.0mV -5.500 to 5.500V -55.00 to 55.00V	
DC voltage scalling ON		-32767 to 32767 [decimal point anywhere]	

· Change of symbol digit and 5th digit

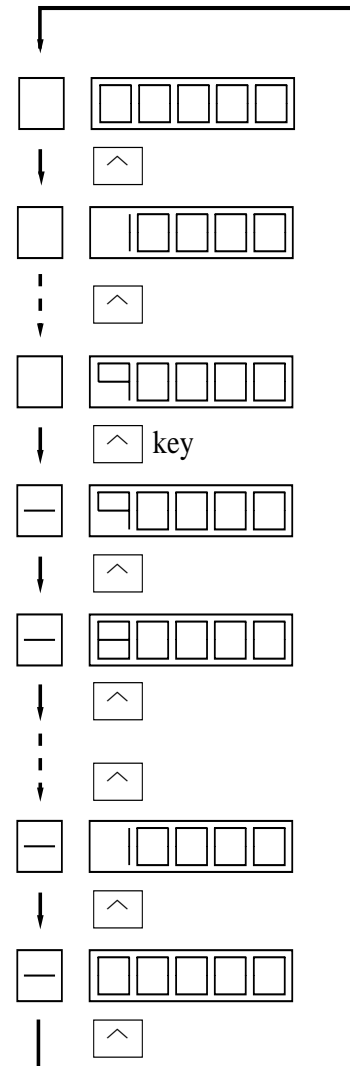













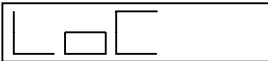



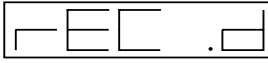



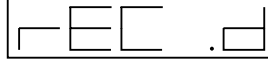

7.11 Selecting whether to start recording when turning on

Explanation

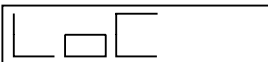
- Selects whether turning on power gets ready to record or not.













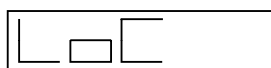

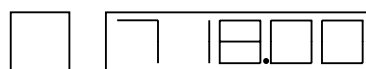





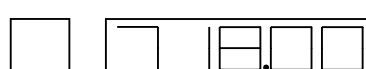



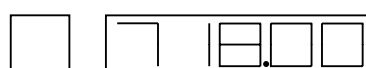

Not ready to record	0
Ready to record	1

Operation contents (ex.)	Turning on power does not get ready to print (OFF).	
Keying	Explanation	Display
 	Press the  key for 3 seconds to display the setting mode. (key lock display appears.)	 
 	Press the  key eight times for displaying whether turning on power gets ready to record or not.	 
 	Press the  key for turning "1" to "0".	  
 	Press the  key to register and transfer to the next parameter display.	 
 	Press the  key for 3 seconds for setting in normal mode.	

7.12 Setting of date and time

Explanation

- Built-in clock is properly set before product shipment. However, if the clock does not keep good time or when the battery is replaced, reset the time.

Operation contents (ex.)	Explanation	Display
 	Press the DSP key for 3 seconds to display the setting mode (key-lock display).	 
 	Press the SEL key 9 times to display the "Time Setting" screen. When nothing is displayed in the left-most digit and T is displayed in the 2nd digit from left, the "Time Setting" screen is displayed.	 ↑
 	Press the ^ key to change the digit of 10'clock. Note) For setting, use a 24H system.	 ↑
 	Press the ENT key to register and shift to the digit of 1 o'clock.	 ↑
 	Press the ^ key to change the digit of 1 o'clock.	 ↑
 	Press the ENT key to register and shift to the digit of 10 min.	 ↑
 	Press the ^ key to change the digit of 10 min.	 ↑
 	Press the ENT key to register and shift to the digit of 1 min.	 ↑
 	Press the ^ key to change the digit of 1 min.	 ↑

Similarly, set date and year.

Date Setting screen

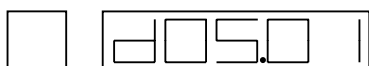

Year Setting screen

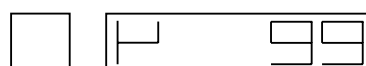

8. MAINTENANCE - INSPECTION

8.1 Maintenance/inspection items

Carry out periodic maintenance and inspection to keep the equipment in good condition.

Pay particular attention to the items noted below and make replacement with spares when necessary.

Inspection, Maintenance Items	Procedure
Recording head replacement:	<p>The recording head is a consumable part.</p> <p>If there is no more ink, replace the head with a new one.</p> <p>Ink consumption varies depending on the contents of records, but writing for about one year is possible at a chart speed of 20mm/h.</p> <p>To get spares, quote the following type.</p> <p style="text-align: center;">Recording head type: PHZH2002/1, 2 continuous recording type PHZH1002/6 dot recording type</p>
Inspection of the recording head	<p>In normal conditions, there is no need for preventive maintenance of the recording head.</p> <p>However, in a high-temperature or very dusty environment, periodically wiping the nozzle surface prevents accumulation of dust and ink and so prevents nozzle blockage that is liable to be caused by such accumulation.</p> <p>To absorb ink, use the supplied "Ink blotting cloth"</p> <p>If the recording head is left unused for a long time without using the cap, ink may not be absorbed when the blotting cloth is attached to the nozzle of the recording head. In such a case, wet the blotting cloth with water and attach it to the nozzle for several 10 seconds until the ink is absorbed sufficiently.</p>
Recording paper replacement	<p>In continuous operation at a chart speed of 20mm/h, the recording paper lasts about 31 days.</p> <p>When there is only a small amount of recording paper left, a red band is printed on the right-hand edge of the paper. When this happens, refer to section 5.1 and replace the recording paper.</p> <p>To get supplementary paper, quote the following type.</p> <p>Recording paper type: PEX00DL1-5000B</p>
Battery replacement	<p>Replace the battery every 5 years. Type of battery unit: TK7J1145C2</p>

8.2 Batteryreplacementprocedure

- * The battery should be replaced every 5 years. If the battery power is lost, time and date cannot be registered when the AC power is not supplied.
- * Turn OFF the power source.
- * Open the front door and replace the battery, using the following procedure.

Step 1

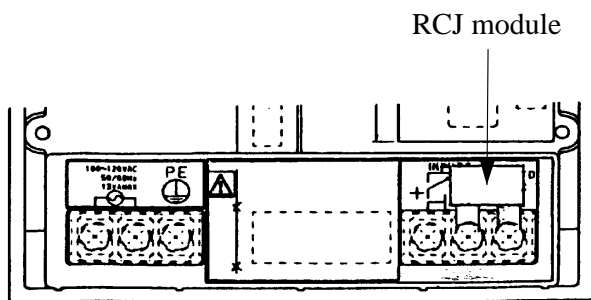

When an RCJ module is attached, it should be removed.

Step 2

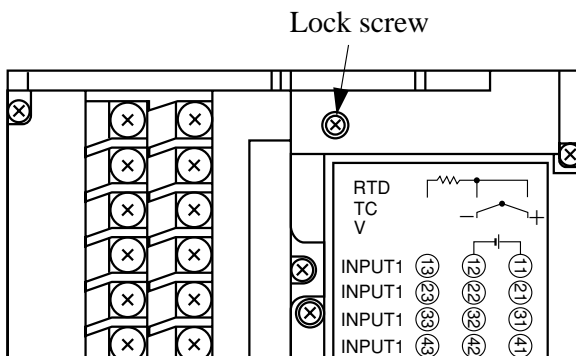

Loosen the lock screw (M4) of the main unit, using a screwdriver ⊕.

Step 3

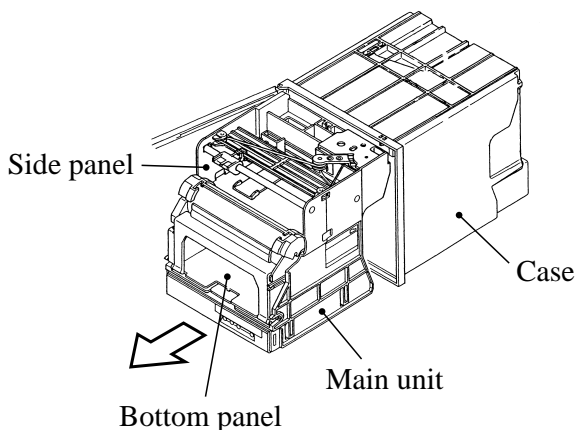

Hold the slide panel or the bottom panel with your fingers, and pull it with force toward you. The main unit will be removed from the case.

Step 4

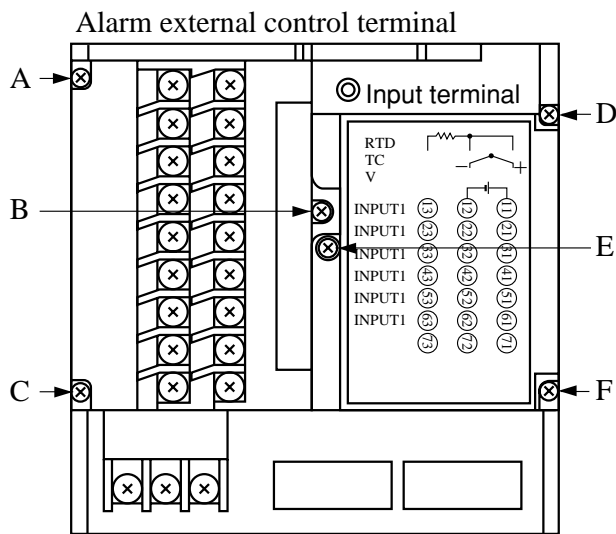

When an alarm is provided, remove the screws, A, B and C (M2.5), then remove the alarm external control terminal. In the case of 6 dot points, remove the screws, D, E and F (M2.5), and then remove the input terminal.

Step 5

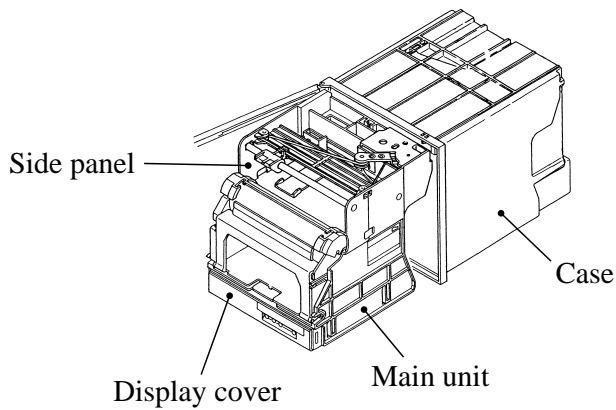

Pull out and remove the main unit from the case.

Pull out and remove the display cover from the main unit.

Step 6 Removal of interface board

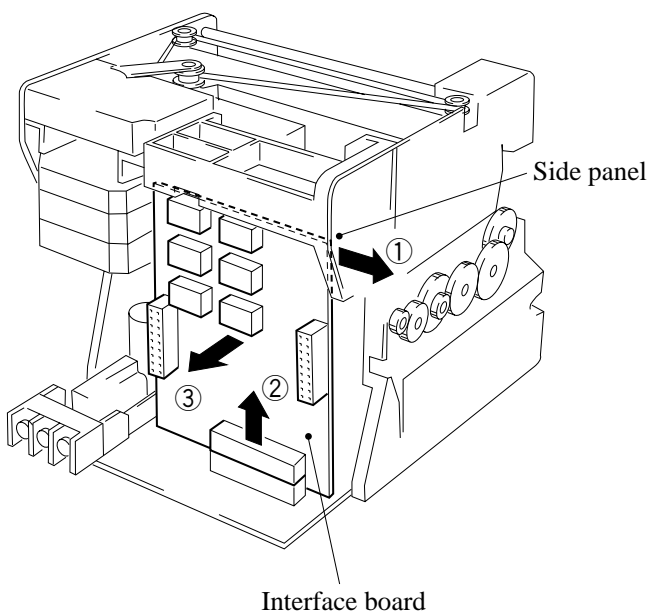

Full the interface board toward you while pressing the side panel outward. The interface board will be removed.

Step 7 Removal of main board

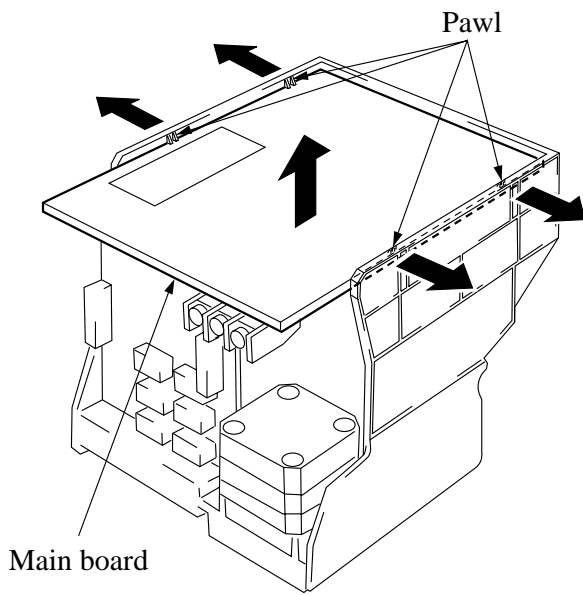

Put the main unit upside down and lift up the main board while pressing the side panel outward, and the main board will be removed.

Step 8 Removal of battery

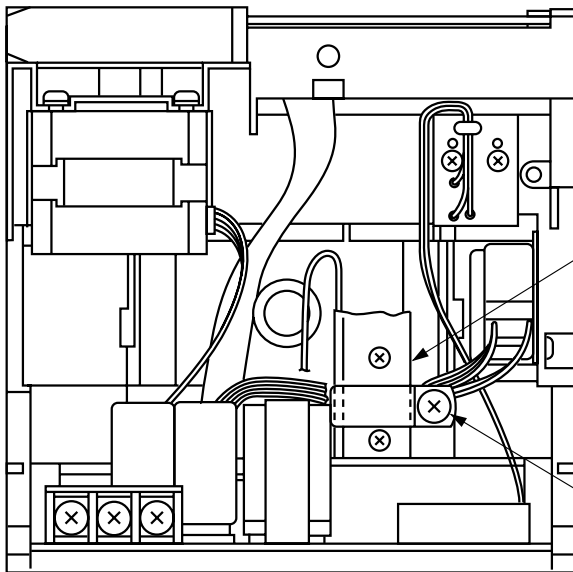

Remove the battery fixing screw (M3), and the battery will be removed.

9. Adjustment mode

Applied operations in this chapter allows:

- ① Adjusting the print-out or record
- ② Adjusting zero and span of analog trend recording position
- ③ PV shift
- ④ Setting the sub chart speed
- ⑤ Skip setting
- ⑥ Selecting the recording head

Any adjustment is easily processed by software.

9.1 How to adjust the printing and recording (adjust the backlash)

Explanation

Proceed to adjustment if characters are off-positioned or recording is disorderly (different between go and return). For the adjustment, calibrating devices need not be connected.

Operation

- ① Press the **[DSP]** key for 3 seconds to display the setting mode. (Key lock display appears.)
- ② Holding down the **[^]** key, press the **[SEL]** key for 3 seconds to transfer to the adjusting mode.

[S] [BAALS] is the display for printing/recording adjustment.

- ③ At the completion of adjustment, press the **[SEL]** key for 3 seconds for setting in normal mode.

<Example>

Press the **[^]** key for displaying **[S] [BAALS]**.

Press the **[ENT]** key.

Press the **[SEL]** key for 3 seconds to resume the display mode.

Print a test pattern and check whether characters are off-positioned or not.

(For test pattern printing method, see 7.5.)

If the character off-position has not sufficiently been remedied, repeat the step ② and subsequent for increasing the backlash value.

If the character off-position has gone for the worse, repeat the step ② and subsequent for decreasing the backlash value.

Repeat the above operation until the status is optimum.

Note:

The backlash value is changeable between 0 and 15. Numerals from 10 to 15 are displayed in characters A through F. The standard value is 5. Normal printing and recording will usually be obtained between 4 and 6.

9.2 How to position the analog trend recording (position the head zero/span)

Explanation

Align the zero (0%) and span (100%) for analog trend recording with chart. In this operation, calibrating devices need not be connected. (Note) This operation is not allowed while recording.

Operation

- ① Press the **REC** key to stop recording.
- ② Press the **DSP** key for 3 seconds to display the setting mode. (Key lock display appears.)
- ③ Holding down the **^** key, press the **SEL** key for 3 seconds to transfer to the adjusting mode.

is the display for printing/recording adjustment.

is a calibrating display for zero and span of analog trend recording.

Press the **^** key for selecting whether to calibrate or not.

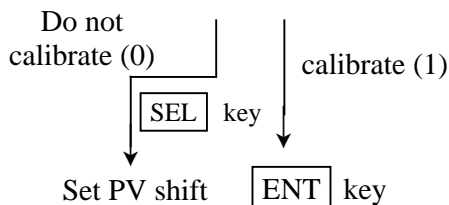

The recording head moves and draws a line at the zero point (0%) in blue for 1 or 2 continuous print-out or in black for 6 dot print-out.

Adjust if recording position is off 0% of recording chart.

Pressing the **^** key moves the recording points to the right.

Pressing the **SEL** key moves the recording points to the left.

After adjusting zero, press the **ENT** key ...Zero calibration ended.

The recording head moves to the 100% point and draws a line at the 100% (span) in blue for 1 or 2 continuous print-out or in different colours for 6 dot print-out.

Adjust if recording position is off 100% of recording chart.

Pressing the **^** key moves the recording points to the right.

Pressing the **SEL** key moves the recording points to the left.

After adjusting the span, press the **ENT** key.

The recording head moves to the center and recording stops. ... Span calibration ended.

Press the **SEL** key for 3 seconds for setting in normal mode.

9.3 How to set the PV shift

Explanation

- Measured value can be calculated by PV shift constant for record and display.
- PV shift calculation is used for setting slope and shift values.

A conversion graph obtained from shift and slope calculation is shown below.

- Shift calculation

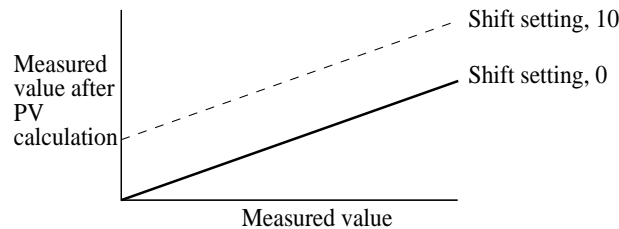

- Gain calculation

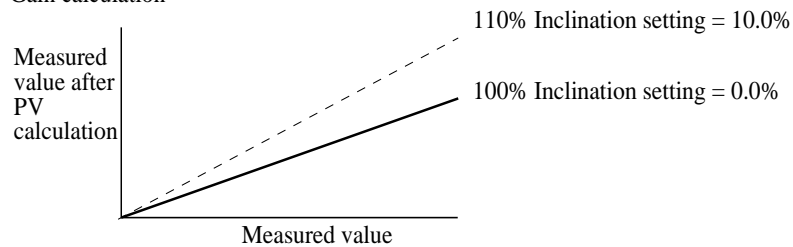

- Details of PV shift calculation is as follows.

$$P' = G P + S$$

P' : Measured value after PV calculation

P : Measured value

G : Gain (87.3 to 112.7%)

(Note) Inclination calculation value is within the range of 87.3 to 112.7% and inclination setting is within the range of -12.7 to 12.7%. Inclination value is calculated by the following equation.

Inclination calculation value =

$$100\% + \text{Inclination setting value}$$

S : Shift value (-127 to 127 industrial value, decimal point depending on type of input)

* Measured value after PV shift calculation, is limited to be set within the record setting range of the type of input set in each channel.

Operation

- ① Press the **DSP** key for 3 seconds to display the setting mode. (Key lock display appears.)
- ② Holding down the **^** key, press the **SEL** key for 3 seconds to transfer to the adjusting mode.

S **BARLS** is the display for printing/recording adjustment.

↓ **SEL** Press the **SEL** key twice to display PV shift setting.

I **PV.SF** is the display for PV shift setting.

↓ **ENT**

Press the **^** key for selecting PV shift setting channel.

↓ **ENT**

S **□□□□** is the input screen for PV shift setting.

S **□□□□**

↑ PV shift set value (setting of the 1st and 2nd digits)
 ↑ Set PV shift value sign (blank for plus, "—" for minus)
 ↑ PV shift set value (setting of the 3rd digit)

Press the **^** key for selecting the set value at each place.

After setting all digits, press the **ENT** key.

↓ **ENT**

G **□□□□** is the display for inputting PV shift gradient.

G **□□□□**

↑ Gradient value (setting of the 1st digit and below decimal point)
 ↑ Set the gradient sign (blank for plus, "—" for minus)
 ↑ Gradient value (setting of the 2nd digit)

Press the **^** key for selecting the set value at each place.

After setting all digits, press the **ENT** key.

↓

Press the **SEL** key for 3 seconds for setting in normal mode.

9.4 How to set the sub chart speed

Explanation

- Chart speed selected by external control input.
- Selects the chart speed out of:
0, 10, 20, 24, 30, 50, 120, 200, 300, 400, 1000, 1200, 1500
Note) 0 mm/h performs no recording.

Operation

- ① Press the **DSP** key for 3 seconds to display the setting mode. (Key lock display appears.)
- ② Holding down the **^** key, press the **SEL** key to transfer to the adjusting mode.

S **BARLS** is the display for printing/recording adjustment.

↓ **SEL** Press the **SEL** key three times for display PV shift setting.

S **C 20** is the display for sub chart speed setting.

Press the **^** key for selecting the sub chart speed set value.

↓ **ENT**

The display appears for the next adjustment setting.

↓
Press the **SEL** key for 3 seconds for setting in normal mode.

9.5 How to set the skip

Explanation

- Skips unused channels.
- For skipped channels, display, recording alarm and other operations are not performed.

Skip ON	1
Skip OFF	0

Operation

- ① Press the **DSP** key for 3 seconds to display the setting mode. (Key lock display appears.)
- ② Holding down the **^** key, press the **SEL** key for 3 seconds to transfer to the adjusting mode.

is the display for printing/recording adjustment.

↓ **SEL** Press the **SEL** key four times for displaying the skip setting.

is the display for skip setting.

↑ Channel No.

Press the **^** key for selecting the channel No. to skip.

↓ **ENT**

Select whether to skip or not

Select "1" to skip or "0" not to skip.

↓

Press the **SEL** key for 3 seconds for setting in normal mode.

9.6 Headselection

Explanation

- Selects a recording head to use.
- There are recording heads for 1 and 2 continuous and 6 dot recording.

6 dot	0
1, 2 continuous	1

- At the time of delivery, it is set to “1” for 1, 2 continuous recording and “0” for 6 dot recording.

Operation

- ① Press the **DSP** key for 3 seconds to display the setting mode. (Key lock display appears.)
- ② Holding down the **^** key, press the **SEL** key for 3 seconds to transfer to the adjusting mode.

S **BARLS** is the display for printing/recording adjustment.

↓ **SEL** Press the **SEL** key five times for displaying the head selection.

□ **HEd .□** is the display for head selection.

↑ Select the head

Select “0” for 6 dot recording or “1” for 1 or 2 continuous recording.

↓ **ENT**

The display for the next adjustment setting appears.

↓

Press the **SEL** key for 3 seconds for setting in normal mode.

9.7 How to calibrate measured value (ADJUST)



Explanation

No adjustment is required normally but only when the measured reading exceeds the guaranteed accuracy.

Applying a calibrating input signal automatically calibrates the value via software. Apply a correct calibrating input signal to a relevant channel.

Note: Applying incorrect input signal causes wrong operation.

Operation

- ① Press the **REC** key to stop recording.
- ② Press the **DSP** key for 3 seconds to display the setting mode. (Key lock display appears.)
- ③ Holding down the **^** key, press the **SEL** key for 3 seconds to transfer to the adjustment mode.

is the display for printing/recording adjustment.

↓ **SEL** Press the **SEL** key twice to display PV shift setting.

is the display for PV shift setting.

- ④ Holding down the **^** key, press the **SEL** key for 3 seconds to transfer to the calibrating mode.

is the display for calibrating zero and span of measured value (Adjust display).

Note) To quit the zero and span calibration for measured value, do not press the **ENT** key but hold down the **SEL** key for 3 seconds. (The display mode is selected.)

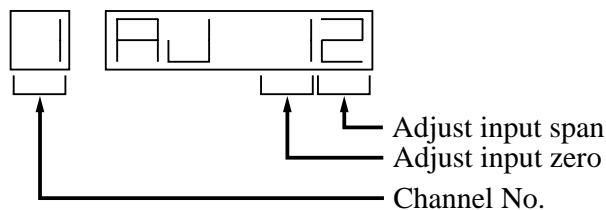

- ⑤ Press $\boxed{\wedge}$ key for selecting the channel No. to calibrate.
 Ch 1 to Ch 6 = DC voltage input, resistance bulb input, thermocouple input
 Ch 7 to Ch 8 = For factory test. Never operate them.

↓ Press the $\boxed{\text{ENT}}$ key

- ⑥ * 1 Apply 0% input

* 1 0% Calibrating input signal is :
 Voltage input : 0 mV or 0V
 Thermocouple input: 0 mV
 Resistance bulb input (Pt, JPt): 100 Ω

$\boxed{\text{ENT}}$ Press the $\boxed{\text{ENT}}$ key. Zero calibration automatically starts.
 “1” turns “0”, which blinks

(After applying 0% input marked *1, press the $\boxed{\text{ENT}}$ key.)

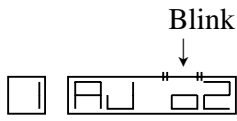

End of zero calibration.....“0” stops blinking and “2” starts blinking,
 whereby standing by for span calibration.

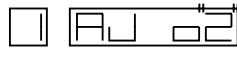

- ⑦ * 2 Apply 100% input * 2

100% calibrating input signal is:
 ± 50 mV : 50 mV
 ± 500 mV : 500 mV
 ± 5 V : 5V
 ± 50 V : 50V
 Thermocouple : 50 mV
 (correction for room temperature is unnecessary)
 Resistance bulb (Pt, JPt) : 324.26 Ω

$\boxed{\text{ENT}}$ Press the $\boxed{\text{ENT}}$ key (after applying 100% input in *2) to start
 automatically the span calibration.
 “2” turns “0”, which blinks.

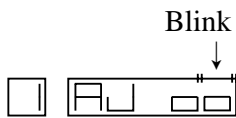

End of span calibration.....The initial screen appears. For adjusting other
 channels, press the $\boxed{\wedge}$ key for selecting them.



- ⑧ Press the $\boxed{\text{SEL}}$ key for 3 seconds to exit from the calibration and resume the display mode.

Note) After selecting a channel No., calibration can not be interrupted with $\boxed{\text{SEL}}$ key until it is
 completed.

To interrupt calibration, turn ON the power again or press the reset button.

10. TROUBLESHOOTING

If the unit fails to operate properly, check the operating conditions and take necessary steps referring to the following.

If any uncontrollable problem arises, contact your dealer or your nearest Fuji service station.

State	Points to check	Action to take
Does not work at all	(1) Is the power supply terminal connection correct?	Connect correctly
	(2) Is power being supplied properly?	Effect proper supply
Keys do not work	(1) Is a parameter list, instantaneous value list, scale print-out or test pattern print-out in progress? The [SEL] key is inoperative during data print-out and list print-out. (See section 2 (4))	Wait until the end of print-out.
	(2) Is Carriage alarm being displayed? * The [FEED] [REC] keys are inoperative when the above state display is produced.	Check the carrier fault.
The record swings over to the 0% side or the 100% side	(1) Is the input signal wiring correct?	Correct the wiring
	(2) Has a thermocouple or resistance bulb wire broken? (If wire breakage occurs, there is a burn-out display and a swing over to the 100% side.)	Replace the thermocouple or resistance bulb.
The record zero/span point is out of position	Refer to Section 9.2 and adjust. Be sure to make the adjustment of Section 9.2 after replacing the recording head.	
There are large errors	Do the input signals match the specification? (Signal source resistance, etc.)	Bring them to the proper specification.
The data display goes to 'Over', 'Under' or 'Error'	Is there supply of excessively large or excessively small input?	Effect supply of correct input
The display goes to 'Carriage Alarm'.	Refer to section 6.8	
Ink does not come out even though there is no 'Ink out' display or the ink colours are blurred.	Carefully note the points described on page 5-7 in relation to the recording head (i.e., the notes on storage and avoiding imposition of vibration or impact). If ink does not flow properly, take the action described on the right. If this has no effect, the recording head must be replaced.	Refer to "Note 5: If the ink is not sprayed" on page 5-8. When the working environment is 15°C or less, perform print-out of "record" or "test pattern" after a period of several minutes has elapsed since the recording head was mounted. (The recording head has a built-in heater.)
Characters are deformed.		
The record colours are wrong.		
Ink does not flow.	Is the head inserted into the carrier sufficiently?	Push the head on properly. (Refer to Step 6 of section 5.2.)
Trend record or characters turn to double-line (round trip difference appears) or characters are disordered.	1) Wire the carriage drive shaft with dry, clean cloth. 2) When this procedure 1) is not effective, follow Section 9.1 Adjustment of backlash	

State	Points to check	Action to take
Time changes at OFF of AC power source	If the time display is in normal operation when the AC power source is left ON, it is an indication that the battery power is lost.	Replace the battery referring to Item 8-2.

11. EXAMPLES OF RECORDING AND PRINTING

Note: If the chart speed is 1000mm/h or higher for continuous recording type or 120 mm/h or higher for dot recording type, periodic print-out, scale print-out (except manual print-out ...see 7.6), alarm print-out and burn-out print-out are not effected.

11.1 Periodic print-out and scale print-out

- ① Periodic print-out: According to the chart speed, printing start line, chart speed and measured values of each channel are automatically printed at fixed intervals.
(provided that periodic print-out is turned on. See 7.7.)
- ② Scale print-out: According to the chart speed, scale line, scale digits, units and channel No. are automatically printed at fixed intervals.
(provided that scale print-out is turned on. See 7.8.)

Example of 2 continuous records

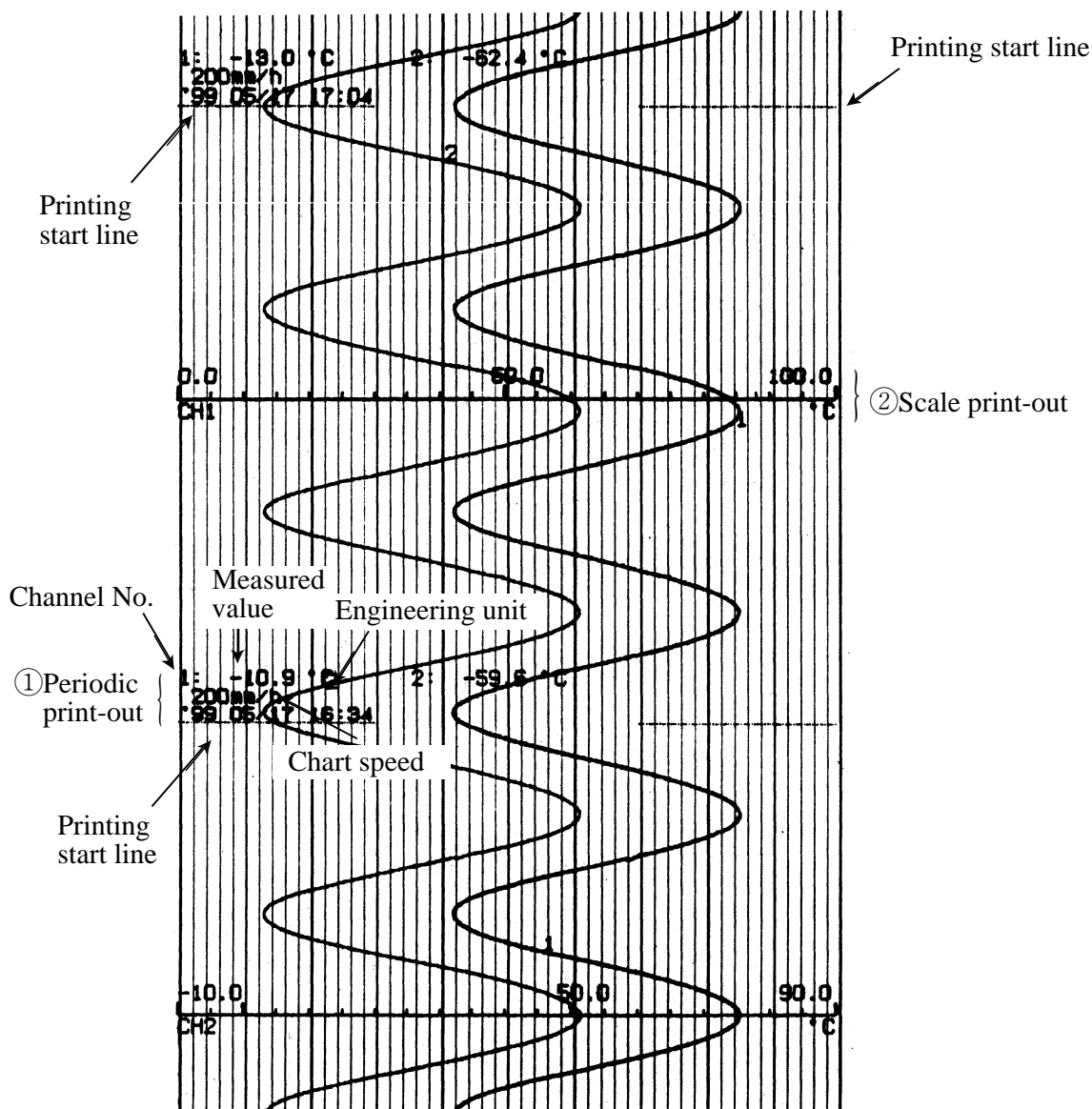

11.2 Digitalprint-out(Instantaneousvalues)

Measured values (instantaneous values) for each channel, engineering units, lapse of time and channel numbers are printed. (See 7.5.)

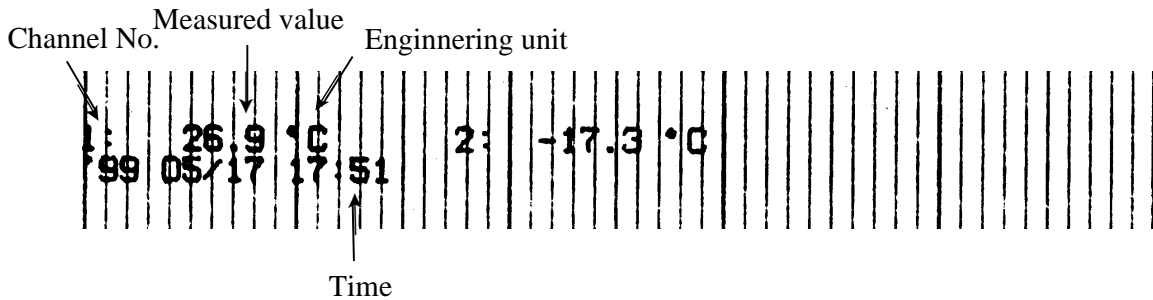

Note) " - " (dash) is printed instead of measured value of channel which is skipped.

11.3 Parameterlisting

Setting contents of parameters are printed in batch on recording chart. (See 7.5.)

The parameter listing is made in the following order of setting.

- Current time
- Main chart speed, sub chart speed
- Periodic print-out ON/OFF, scale print-out ON/OFF, recording ON/OFF when turning on power.
- Channel No., input signal, recording range, measuring range, engineering value, PV shift/gradient, input filter/unit
- Channel No., alarm No. 1 kind/set value/DO relay No., alarm No. 2 kind/set value/DO relay No.

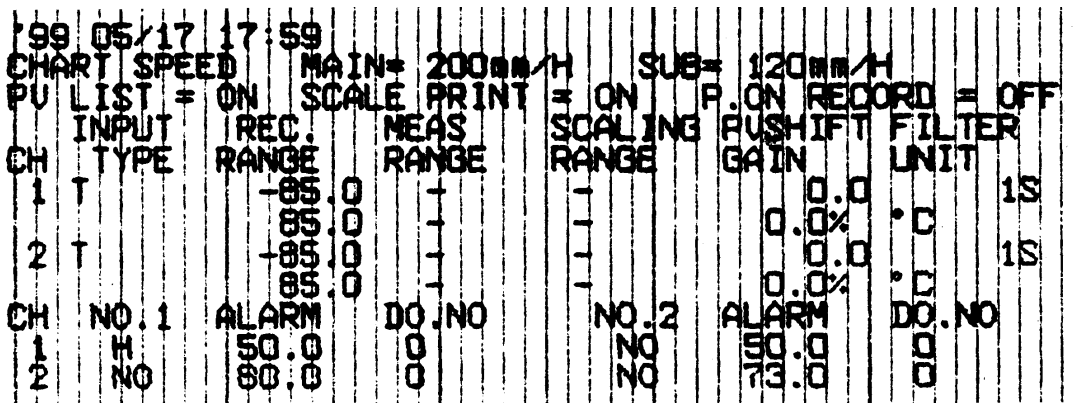

11.6 Alarmprint-outs

When an alarm is detected and canceled, the time of detection and cancellation and the channel No. are printed on the right-hand side of the recording paper.

On detection: print-out colour red, on cancellation: print-out colour: blue(1,2 continuous recording)
black (6 dot recording)

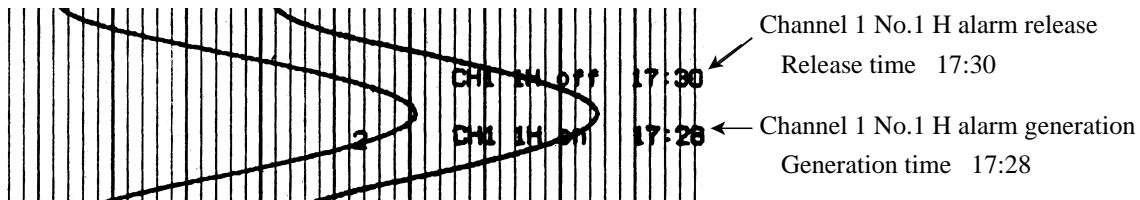

11.7 Burn-outprint-out

If a burn-out occurs, the channel No. burn-out and time of occurrence are printed in red at the right-hand edge of the recording paper.

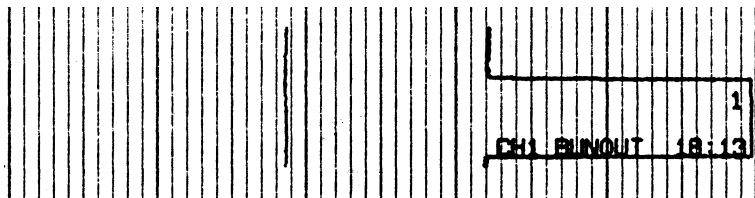

11.8 Recordstartmark

When recording starts, a record start mark is printed at the left-hand edge of the recording paper (outside the 0% scale line).

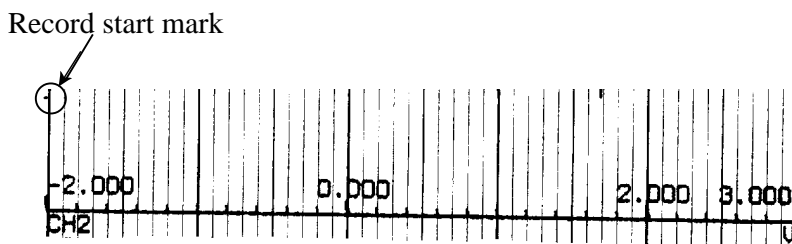

11.9 Chart speed changemark

If a change in the speed of the recording paper is ordered, a chart speed change mark is printed at the left-hand edge of the recording paper (inside the 0% scale line).

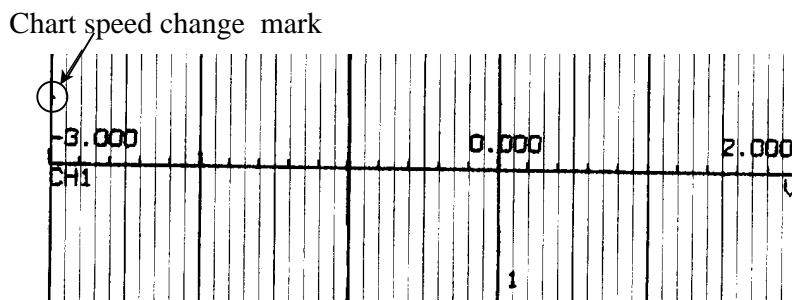

12. SPECIFICATION

InputSection

Number of input points: 3 classes: 1, 2 continuous recording and 6 dot recording

Input signals: Thermocouple input: B, R, S, K, E, J, T, N, W, L, U, PN
Resistance bulb input: Pt100, JPt100 (JPt means special input in Japanese)
DC voltage input: 50 mV range, 500 mV range, 5V range, 50V range
Direct current input: 4 to 20 mA DC. 10 to 50 mA DC
(Note: Terminal section to be fitted with separately sold 10 Ω shunt resistor and range to be made 500 mV.)

Maximum allowable input voltage:

Thermocouples, resistance bulbs, DC voltage (50 mV, 500 mV range):
 ± 10 V DC

DC voltage (5V, 50V range): ± 100 V DC

Burn-out function : In case of thermocouple or resistance bulb input open-circuiting, overswings the recording to 100% side.

Input range : 1 continuous: 1 kind
2 continuous: 2 kinds
6 dot : 1 or 2 kinds

Note) During input of 6 dot signals from a resistance bulb, the line between channels is not insulated.

Display accuracy and resolution : Under measuring and recording conditions

(temperature: $23 \pm 5^{\circ}\text{C}$, relative humidity: $65 \pm 10\%$, source voltage and frequency fluctuation: within $\pm 1\%$, vertical mounting, no external noise, signal source resistance or wiring resistance: 1% max. of specified value, warm-up: 30 min or more)

Input signal		Max. input range		Indicating accuracy	Indicating resolution
Thermo-couple	B	400 to 1760°C	752 to 3200°F	<u>I. Thermocouple</u> ①Recording range span 8 mV or more $\pm(0.3\%$ of recording range + 1 digit) ②Recording range span 4 to 8 mV $\pm(1.0\%$ of recording range + 1 digit) Excluding reference junction compensating error <u>II. Resistance bulb</u> ①Recording range span 36 Ω or more $\pm(0.3\%$ of recording range + 1 digit) ②Recording range span 18 to 36 Ω $\pm(1.0\%$ of recording range + 1 digit) III. DC voltage ①Recording range span 8% FS or more $\pm(0.3\%$ of recording range + 1 digit) ②Recording range span 4 to 8% FS $\pm(1.0\%$ of recording range + 1 digit)	0.1°C, 0.1°F
	R	0 to 1760°C	32 to 3200°F		
	S	0 to 1760°C	32 to 3200°F		
	K	-200 to 1370°C	-328 to 2498°F		
	E	-200 to 800°C	-328 to 1472°F		
	J	-200 to 1100°C	-328 to 2012°F		
	T	-200 to 400°C	-328 to 752°F		
	N	0 to 1300°C	32 to 2372°F		
	W	0 to 1760°C	32 to 3200°F		
	L	-200 to 900°C	-328 to 1652°F		
	U	-200 to 400°C	-328 to 752°F		
Resistance bulb	P N	0 to 1300°C	32 to 2372°F		
	JPt100	-200 to 600°C	-328 to 1112°F		
	Pt100	-200 to 600°C	-328 to 1112°F		
DC voltage	50mV	-50 to +50mV			10 μ V
	500mV	-500 to +500mV			100 μ V
	5V	-5 to +5V			1mV
	50V	-50 to +50V			10mV

Note) The rated indicating accuracy is in percentage with respect to recording range.

1 digit refers to indication change at least significant digit of indication.

Note) The indication accuracy in the thermocouple recording range (-200 to -100°C) is $\pm(1.0\%$ of recording range + 1 digit).

Note) The indication accuracy in the R, S thermocouple recording range (0 to 300°C) is $\pm(1.0\%$ of recording range + 1 digit).

Recordingsection

Recording method:	Ink jet type, 6 or 3 colours
Effective recording width:	100 mm
Recording colours:	1 continuous type : Recording ----- Violet Printing ----- Violet
	2 continuous type : Recording ----- Channel 1 in red Channel 2 in blue Printing ----- Violet
	6 dot type : Recording ----- Channel 1 in orange Channel 2 in green Channel 3 in violet Channel 4 in red Channel 5 in black Channel 6 in blue Printing ----- Black
Recording chart:	Z-folding.....15.08m long
Recording accuracy:	Indicating accuracy +0.2%
Recording solution:	0.1mm
Chart speed:	10, 20, 24, 30, 50, 120, 200, 300, 400, 1000, 1200, 1500mm/h [Note]Above 400mm/h, continuous recording is made on intermittent type.
Speed setting method:	On keyboard.
Recording cycle:	Dot records ... 30 seconds/for all points. Continuous recording... Depends on chart speed <Calculation expression> Recording cycle (seconds) = 400/[chart speed (mm/h)] or 2 seconds, whichever greater
Measuring cycle:	1, 2 continuous : 200 msec/point 6 dot : 30 sec/all points
Ink life (depending on operating conditions) :	1 continuous ----- approx. 20 months 2 continuous ----- approx. 12 months 6 dot ----- approx. 8 months

Display section and keying section

Display method: LED (7 segments), 6 digits, green

Display characters: 7-segment alphanumerics, 10 mm high, 5 mm wide

Display contents:

- (1) Time : hour & min
- (2) Channel number : 1 digit (1 to 6)
- (3) Measured value : 5 digit (including sign if below 0)
 - Temperature... 1 digit below decimal point
 - Voltage, current... As per scaling.
 - 9999 for -10000 or beyond
- (4) Status display : Code indicating alarm, burn-out
Code indicating carriage error
- (5) Measured value display cycle :
 - Channel change over... 3 sec.
 - Updating data within channel... 1 sec.

Operating keys: 3

Key lock : Soft key lock available by key operation.

Printingsection

Printing method: Ink jet type

Ink colors: 1, 2 continuous type : Blue, blue, red, red, 2 colors (4 bags)
6 dot : Black, blue, red, yellow, 4 colors

Recording colors: 6 or 3

Mixed colors : (Orange, green, violet). 2 different colors put on same point.

Channel No.	1	2	3	4	5	6	Character
1 continuous recording	Violet	—	—	—	—	—	Violet
2 continuous recording	Red	Blue	—	—	—	—	Violet
6 dot recording	Orange	Green	Violet	Red	Black	Blue	Black

Automatically printed at following print-out analog recording.

Periodic print-out: Instantaneous value, unit, date, time, time line and paper feed speed
[Note] Printing intervals are automatically determined by recording chart speed.

Scale print-out: Scale line print-out for sequential channels is effected alternately with periodic print-outs.
[Note] Printing intervals are automatically determined by chart speed.

Alarm print-out: Channel No., alarm kind, occurrence/reset time at occurrence/reset of the input alarm

Burn-out print-out: Channel and time at burn-out occurrence

Others: Recording start mark print-out. Recording paper feed speed change mark print-out.

Following print-out activated by keying suspends analog recording. After the end of print-out, the analog recording is resumed.

Instantaneous value list: Print-out of each channel measured value (instantaneous value) and engineering unit, lapse of time, channel number

Parameter list: Print-out of input signal, input range, recording range, unit, alarm, input filter, (set value list) chart speed.

Scale print-out: Print-out of scale line of desired channel (manual)

Test pattern: Print-out of color pattern and test characters

Performance, characteristics

- Input resistance: 10 M Ω or more (50 mV range, thermocouples)
Approximately 100 k Ω (500 mV range)
Approximately 1 M Ω (5V, 50V range)
- Chart speed accuracy: $\pm 0.1\%$ (For continuous feed of 1m or more. Does not include paper elongation/shrinkage.)
- Accuracy of clock: Better than ± 50 ppm (lunar equation: about 2 min)
- Insulation resistance: 100 M Ω (across each terminal and ground at 500V DC)
- Withstand voltage: Input terminal - input terminal : 500VAC 1 minute
Power supply terminal - ground : 2000VAC 1 minute
Input terminal - ground : 500V AC 1 minute
Power terminal - input terminal : 2000VAC, 1 minute
Between alarm terminals : 750VAC, 1 minute
(Leakage current 5 mA or less)
- Reference junction compensation precision: K, E, J, T, N, L, U, PN $\pm 0.5^\circ\text{C}$
R, S, B, W $\pm 1^\circ\text{C}$

Construction

- Mounting method: Mounted in panel (vertical panel)
Inclination (angle) = 90 to 60 $^\circ$ horizontal (left to right)

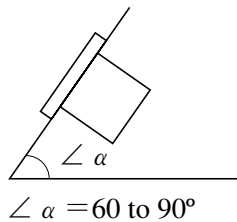

- Material: Case: mould (Black)
Front flap frame: mould (Black)
- Mass: Continuous type Approx. 1.3 kg (without alarm terminal)
Approx. 1.5 kg (with alarm terminal)
Dot type Approx. 1.5 kg (without alarm terminal)
Approx. 1.7 kg (with alarm terminal)
- External dimensions: 144 \times 144 \times 175 mm (continuous recording type)
144 \times 144 \times 197 mm (dot recording type)
- External terminals: Screw terminals (M4 thread)

Power supply section

- Rated power voltage: 100 to 120VAC or 200 to 240VAC (designation)
- Range of operating power voltage: 85 to 132VAC or 180 to 264VAC
- Supply frequency: 50/60 Hz both employable
- Power consumption: 100 to 120VAC, 200 to 240VAC without options approximately 13 VA
100 to 120VAC, 200 to 240VAC with all options approximately 15 VA

Normal operating condition (Condition of device designed for normal continuous operation)

Ambient temperature: 0 to 50°C

Ambient humidity: 20 to 80% RH, but temperature × humidity < 3200

Vibration: 10 to 60 Hz, 0.2m/s² {0.02G} or less

Mounting attitude: Forward tilt 0°, rearward tilt within 30°, left/right 0°

Signal source resistance: Thermocouple input 1kΩ or less

Voltage input 0.1% or less of input resistance

Resistance bulb input 10Ω / wire or less (resistance of each wire of 3-wire system should be balanced).

Warm-up time: 30 minutes or more

Impact: none

Effects of operating conditions

Effects of power source fluctuation: 100 VAC base With 85 to 132 VAC fluctuation
(frequency 50 or 60 Hz)

200 VAC base With 180 to 264 VAC fluctuation
(frequency 50 or 60 Hz)

Indication variation: ±(0.1% of reference range + 1 digit)

Recording variation: ±0.2% of record span

With 47 to 63 Hz fluctuation (power supply voltage: 100VAC)
50 Hz base

Indication variation: ±(0.1% of reference range + 1 digit)

Recording variation: ±0.2% of record span

Effect of input source resistance and wiring resistance:

Thermocouples 10μV per 100Ω

Variation with resistance value equivalent to 0.1% of the input value in the case of voltage

Indication variation: ±(0.1% of reference range + 1 digit)

Recording variation: ±0.2% of record span

Variation with fluctuation of 10Ω per line in the case of resistance bulbs

Indication variation: ±(0.1% of reference range + 1 digit)

Recording variation: ±0.2% of record span (if all 3 lines have the same resistance)

Effect of ambient temperature : Indication variation: ±(0.3% of reference range + 1 digit) / 10°C

Recording variation: ±0.5% of record span / 10°C

Effect of mounting attitude:	With rearward tilt within 30° Indication variation: $\pm(0.1\%$ of reference range + 1 digit) Recording variation: $\pm 0.2\%$ of record span
Effect of vibration:	On 2 hours imposition of frequency 10 to 60 Hz, acceleration 0.2m/s^2 {0.02G} linear vibration in each of 3 axes Indication variation: $\pm(0.1\%$ of reference range + 1 digit) Recording variation: $\pm 0.2\%$ of record span
Effect of external noise:	Normal mode noise reduction ratio (50, 60 Hz)....30 dB or more Common mode noise reduction ratio (50, 60 Hz)....120 dB or more
Recording paper:	On 20°C, 60% RH base Elongation at 85% RH: 0.4% or less Shrinkage at 35% RH: 0.5% or less

Alarms

Setting method:	Set from keyboard.
Number of settings:	Setting of Max. 2 points for each channel. (high limit 2 points, low limit 2 points or high / low limit)
Display:	On detection, display section indication of output relay Nos. for each channel
Print-out:	Channel number, alarm kind, output relay number, occurrence/reset time on chart paper
Output:	As in supplementary specification
Hysteresis amplitude:	About 0.2% of record span

Transport, storage conditions

(For transport or storage, be sure to remove the recording head from the unit and fully tighten the cap.)

Temperature:	-20 to +70°C
Humidity:	95% RH or less (but to be no dew condensation)
Vibration:	5 to 60 Hz, 2.45m/s^2 {0.25G} or less
Impact:	294m/s^2 {30G} or less

Referencestandards

Safety Standards:	IEC1010-1 (1990) <div style="display: inline-block; vertical-align: middle; margin-left: 20px;"> <div style="font-size: 2em; vertical-align: middle;">{</div> <div style="display: inline-block; vertical-align: middle; margin-left: 5px;"> reinforce insulation overvoltage category II except alarm output terminals <p style="text-align: right;">(overvoltage category I)</p> pollution degree 2 </div> </div>
EMC Standards:	EN50081-1 (1992), EN50082-1 (1992)

Dust/drip-proofing: IP50

Additional specification

(1) Alarm relay output (DO)

- 1a contact output for two, four, six-points
- output of channels is available individually or commonly (OR operation)
- Contact capacity : 240 V AC, 3A. 30 V DC, 3A (resistive load).
- Alarm relay output unit is necessary

(2) External control (DI):

By external contact input, following operation is made.

- 2-stage chageover of chart speed (which is set by keyboard)
- Setting the sub chart feed speed to 0mm/h allows recording start/stop changeover
- External control unit is necessary (where alarm relay is the same as output)

Note) The external control unit is not insulated, so an external relay should be used.

External contact capacity : DC12V/0.05A, 1a contact

Standard functions

Function		Contents
Skip function		Skips recording, indication or alarm of desired channel.
Listing function	Instantaneous values list	Prints date, time and measure value, unit and channel number of each channel.
	Parameter list	Prints input signal, input range, recording range, unit, alarm, input filter, chart speed, etc.
	Test pattern	Prints test characters and colour patterns.
	Scale print-out	Prints scale of desired channel.
Periodic print-out function		Prints periodic printing start line, date, time and paper feed speed and measured value of each channel at fixed intervals.
Scale print-out function		Prints scale of channels in their order alternately with periodic print-out.
Alarm print-out function		Prints time, channel number, alarm kind and output relay number at occurrence/reset of alarm.
PV shift function		Subjects measured value to summation and subtraction to shift the values to display or record in order to offset the difference in measured value by other instrument.
Input filter		Retards the response to abrupt change of input for each channel (first order lag filter). Time constant settable range : 0 to 255 sec.
Burn-out function		In case of thermocouple or resistance bulb open circuiting, overswings to the maximum value side of recording range and simultaneously displays and prints the input.

APPENDIX 1. MOUNTING OF PHE OPTIONAL UNITS

Optional units include alarm unit and alarm and external control unit.

They are available in the following types.

2 alarm points + 1 external control point for 1-continuous type
4 alarm points + 1 external control point for 2-continuous type
6 alarm points + 1 external control point for 6-dot type

•How to mount alarm terminal

1. Case of 1-continuous type or 2-continuous type

- Be sure to turn OFF the power before starting the work.

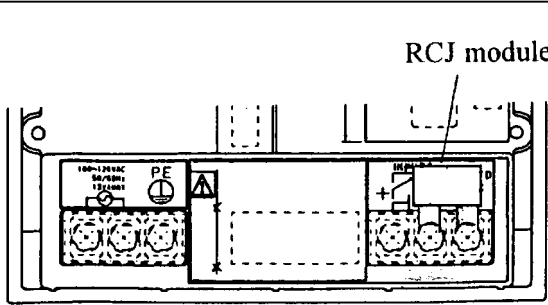
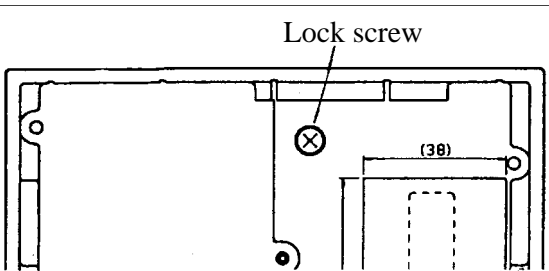
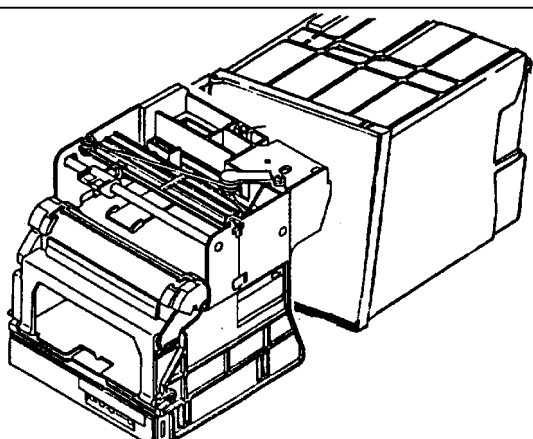
Step 1	 <p>RCJ module</p>	<p>Remove the reference contact compensation module (RCJ module) for thermocouple and shunt resistance of 4 to 20mA input, if provided.</p> <p>(If power supply wiring and input terminal wiring are laid, remove all these wires.)</p>
Step 2	 <p>Lock screw</p> <p>(38)</p>	<p>Remove one lock screw, which is fixing the main unit to the case.</p>
Step 3		<p>Pull out the main unit from the case.</p> <p>Caution: Be careful at this time not to miss out the nuts provided for the main unit.</p>

Step 4

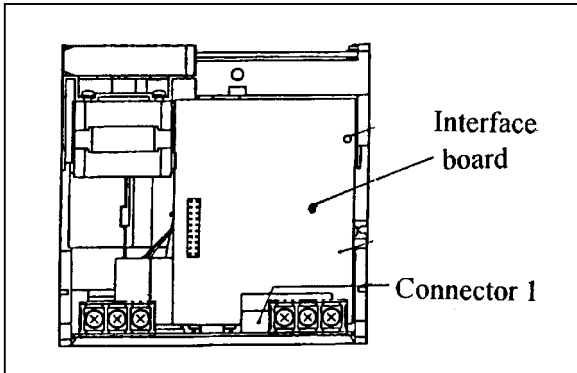

Insert the interface board into connector 1 (CN1) located in the rear part of the main board.

Step 5

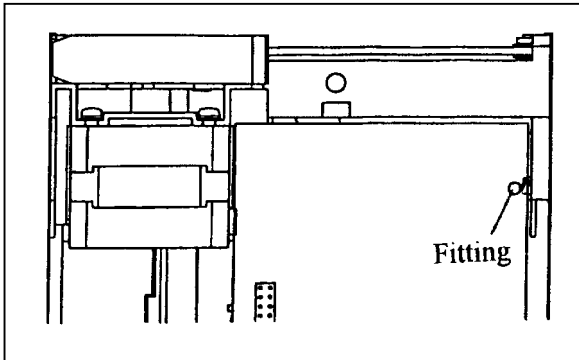

Fit the hole located in the right upper part of the interface board to the main unit.

Step 6

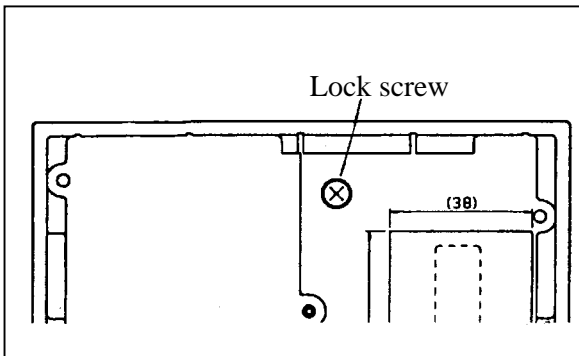

Return the main unit to the case, and fasten one lock screw that fixes the main unit.

Step 7

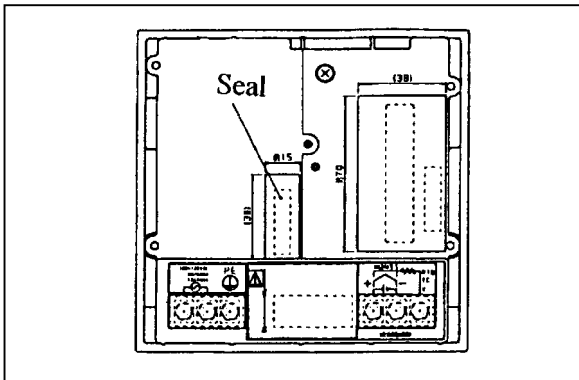

Remove the covering seal from the rear face of the main unit.

A connector will appear.

Step 8

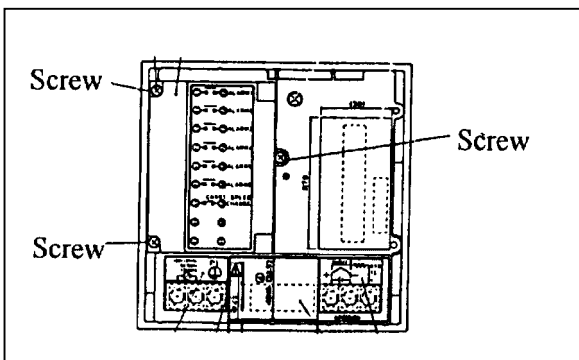

Insert the plug of the alarm unit or alarm and external control unit into the connector on the main unit side.

Fix the alarm unit or alarm and external control unit by three lock screws.

2. Case of 6-dot type

- Be sure to turn OFF the power before starting the work.

Step 1

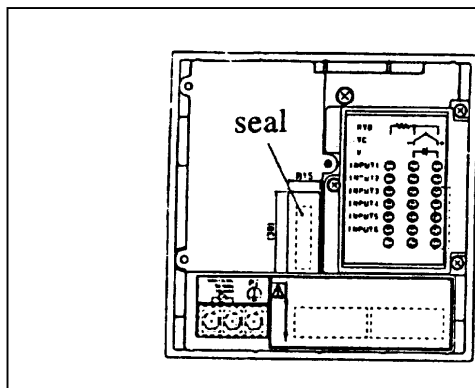

Remove the covering seal from the rear face of the main unit.

A connector will appear.

Step 2

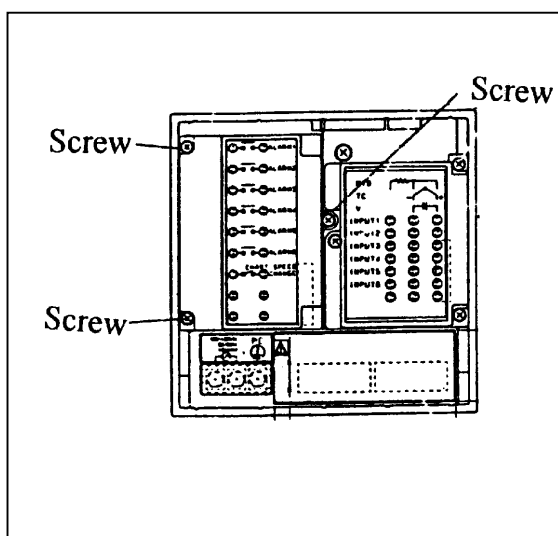

Insert the plug of the alarm unit or alarm and external control unit into the connector on the main unit side.

Fix the alarm unit or alarm and external control unit by three lock screws.

APPENDIX 2. SYSTEM PARAMETER SETTING

1. OUTLINE OF SYSTEM PARAMETER SETTING ITEMS	B - 2
2. OUTLINE OF SYSTEM PARAMETER SETTING MODE	B - 3
3. SYSTEM PARAMETER SETTING PROCEDURE	B - 5
3.1 Input type setting	B - 6
3.2 Recording range setting	B - 12
3.3 Calibration of measured value	B - 13
3.4 Industrial unit setting	B - 15
3.5 Channel No. print function OFF	B - 17
3.6 Reference contact compensation function (RCJ) OFF	B - 17
3.7 Setting of print-out intervals of periodic print-out and scale print-out	B - 17
3.8 Setting of external contact input (DI) function	B - 18
3.9 Alarm print-out function OFF	B - 19

1. OUTLINE OF SYSTEM PARAMETER SETTING ITEMS

The following items, 1, 2 and 4 to 9, can be set for setting system parameters.

① Input type setting (including scaling setting)

- Method of setting the input type (thermocouple, resistance bulb, voltage) of each channel is mentioned.
- When the input is thermocouple or resistance bulb, its unit (°C/ °F) can be set selectively.
- Methods of setting the measurement range, decimal point position, industrial value and unit symbol at scaling ON with voltage input, are mentioned.



- On the input type setting, when the setting needs to be changed, be sure to calibrate the channel that has been changed. (For the method of calibration, refer to Item 3.3 “Calibration of measured value”)

② Recording range setting

- The method of setting the recording range of each channel is mentioned. Recording range is not automatically changed at change of input type.

③ Calibration of measured value

- The method of calibrating measured value is mentioned, though this item is not included in parameters of “System parameter setting mode”.

④ Industrial unit setting

- Industrial unit (unit symbol) of each channel can be set in maximum 7 characters. Unit characters are set on each character.

⑤ Channel No. print function OFF

- Printing of channel No. on recording line can be disabled by setting this function.

⑥ Reference contact compensation function (RCJ) OFF

- Reference contact compensation function at thermocouple input can be stopped.

⑦ Setting of print-out intervals of periodic print-out and scale print-out.

- Print-out interval for periodic print-out and scale print-out can be set.

⑧ Setting of external contact input (DI) function

- Measured value can be printed with external contact input (DI) (“Chart speed select” function is used for normal DI).

⑨ Alarm print-out function OFF

- Alarm generation/release print-out can be set not to be burnt out.



- When the setting of this system parameter has been changed (Item 1 to 9, excluding the calibration in Item 3), reset the main unit or turn ON the power again. (The main unit can be reset by pressing the reset switch on the front key-board)

2. OUTLINE OF SYSTEM PARAMETER SETTING MODE

- This mode is classified into 5 steps.

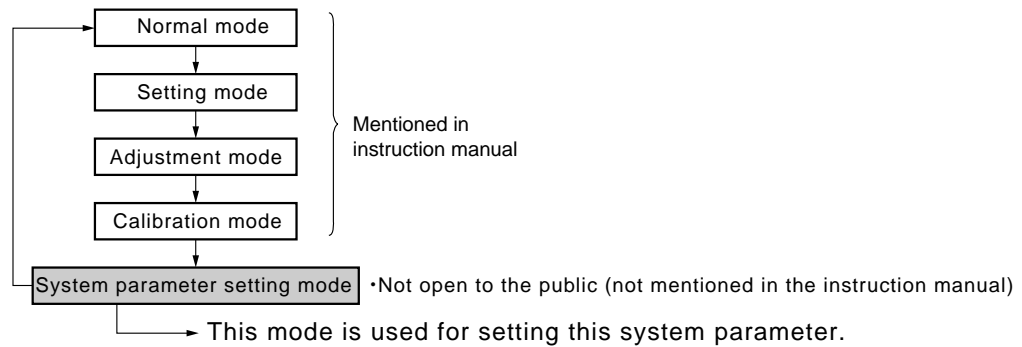

Normal mode

At each press of the DISPLAY key, the display changes as shown below (initial screen is time display).

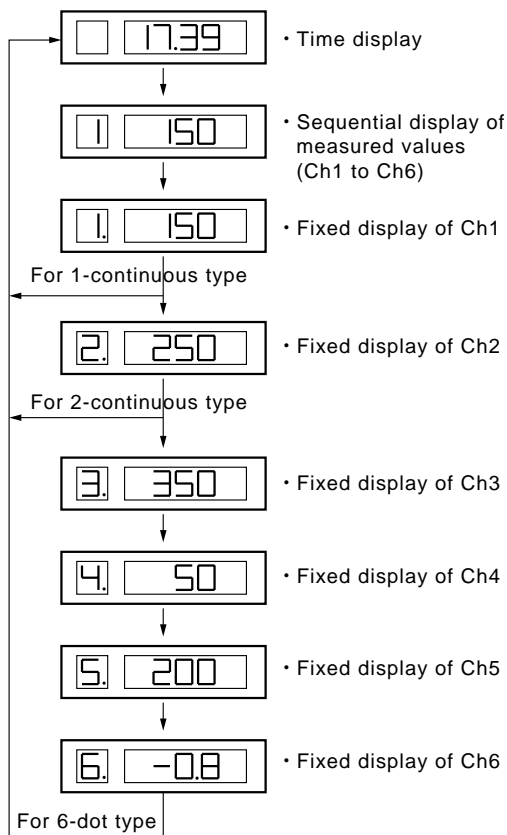

Setting mode

By pressing the DISPLAY key for more than 3 seconds, the setting mode screen changes as shown below (display of initial screen “Key lock” of setting mode).

At each press of the SELECT key, the display is selected as shown below.

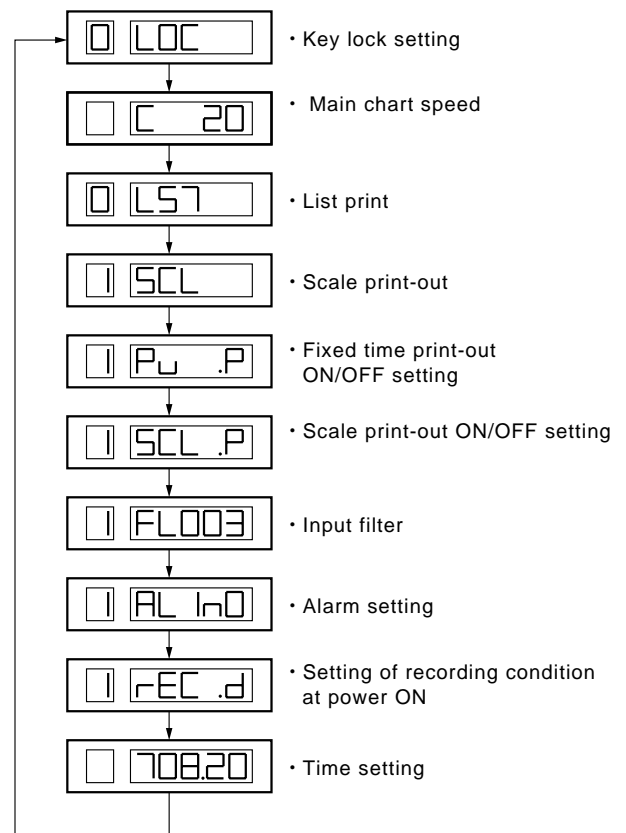

Adjustment mode

By pressing the SELECT key for more than 3 seconds while pressing the UP key under the condition that the initial screen “Key lock” of setting mode is displayed, the adjustment mode screen is selected as shown below (display of initial screen “Black-lash” of adjustment mode). At each press of the SELECT key, the display changes as shown below.

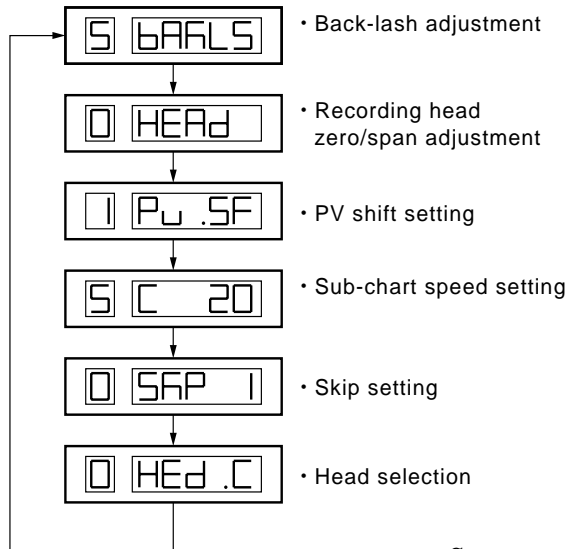

Calibration mode

By pressing the SELECT key for more than 3 seconds while pressing the UP key under the condition that the PV shift screen “Pu. SF” of the adjustment mode is displayed, the calibration mode screen is selected as shown below (display of initial screen “1AJ 1S” of calibration mode). At each press of the SELECT key, the display changes as shown below.

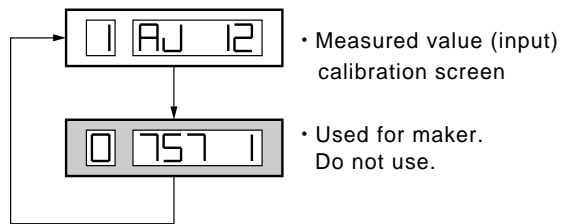

System parameter setting mode

While the initial panel “1AJ 1S” of calibration mode displayed, press the UP key to display “7AJ 1S”, then press the SELECT key for more than 3 seconds while pressing the UP key.

The system parameter setting panel is selected as shown below (display of initial panel “Input type setting” of system parameter setting mode).

At each press of the SELECT key, the display changes as shown below.

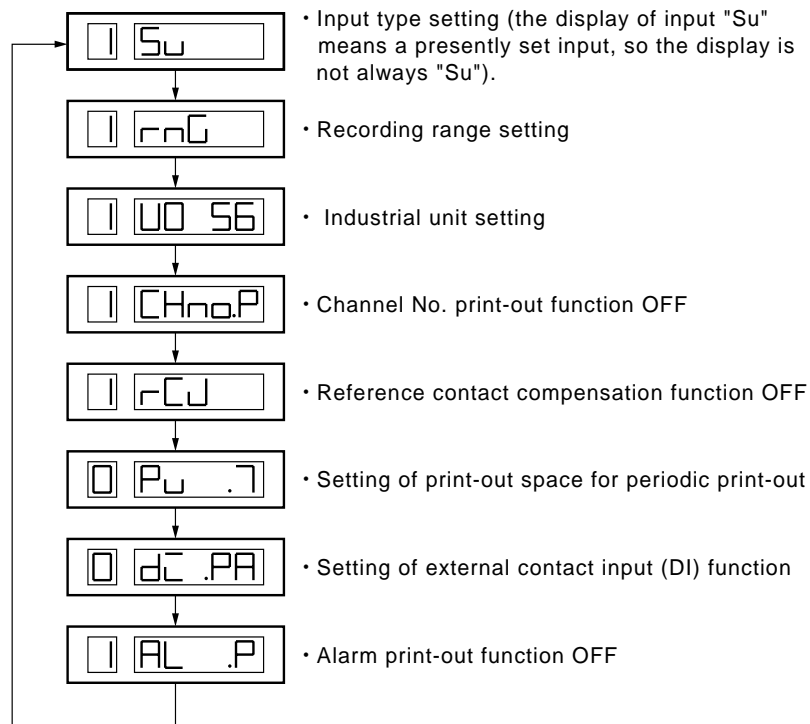

3. SYSTEM PARAMETER SETTING PROCEDURE

- Input type setting is made by setting the pins and operating the keys on the front. Other settings are all made by operating the keys on the front.
- To gain access to the system parameter setting, use the following procedure.

By pressing the DISPLAY key for more than 3 seconds, the setting screen display changes as shown below.

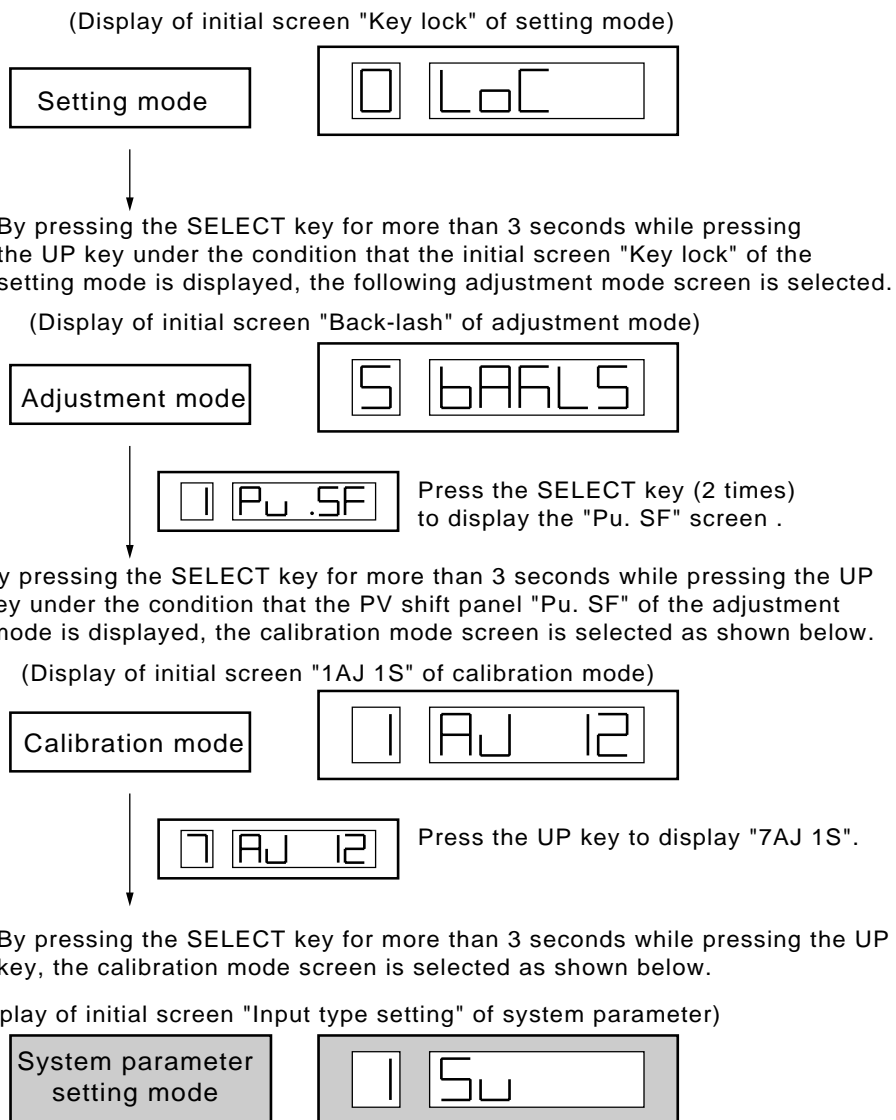

3.1 Input type setting

- Set the type of input of each channel. The following 2 items are required for setting the input of each channel.

- ① Setting of pins for hardware
- ② Change of setting by operating the keys on the front key-board for software

This setting may also be made by simply changing the software setting, without changing the pin setting.



- * When the input type setting has been changed, calibrate the input of the channel that has been changed.
- * Calibration is not required for changing the type of thermocouple, for example, from the K-thermocouple to T-thermocouple or for changing the type of resistance bulb, for example, from resistance bulb JPt100 to Pt100.

(1) 1-continuous type

Thermocouple	Change of input in this group can be set from the front key-board alone. Input calibration is required for the channel that has been changed.
Resistance bulb	
$\pm 50\text{mV}$	
$\pm 500\text{mV}$	When changing the range from one bold frame group to another, the pin setting and the software setting are required. Input calibration is also required for the channel that has been changed.
$\pm 5\text{V}$	
$\pm 50\text{V}$	

(2) 2-continuous type

Thermocouple	When changing the range from one bold frame group to another, the pin setting and the software setting are required. Input calibration is also required for the channel that has been changed.
Resistance bulb	
$\pm 50\text{mV}$	
$\pm 500\text{mV}$	
$\pm 5\text{V}$	
$\pm 50\text{V}$	

(3) 6-dot type (Input: Ch1 to Ch6)

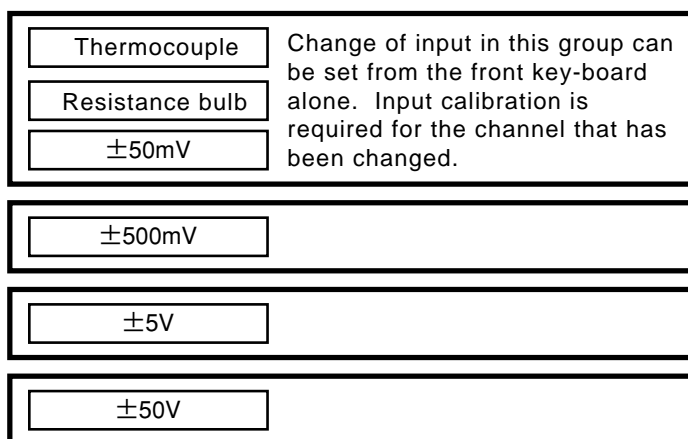

When changing the range from one bold frame group to another, the pin setting and the software setting are required. Input calibration is also required for the channel that has been changed.

3.1.1 Method of setting input type and setting pin

(1) 1-continuous or 2-continuous type

- ① Turn OFF the input power for the recorder.
- ② Remove the input wiring and the power supply wiring.
- ③ If a reference contact compensation module (RCJ module) for thermocouple and a shunt resistor for 4 to 20mA input are attached, they should be removed.
- ④ If an alarm unit is attached, it should be removed.
- ⑤ Remove the screw (1 pc) holding the main unit to the case, then draw out the main unit.
- ⑥ Set the setting pin on the main board referring to Fig. 3.1 "Pin setting specifications".
- ⑦ When the setting is finished, return the main unit to the case by reversing the above work procedures.

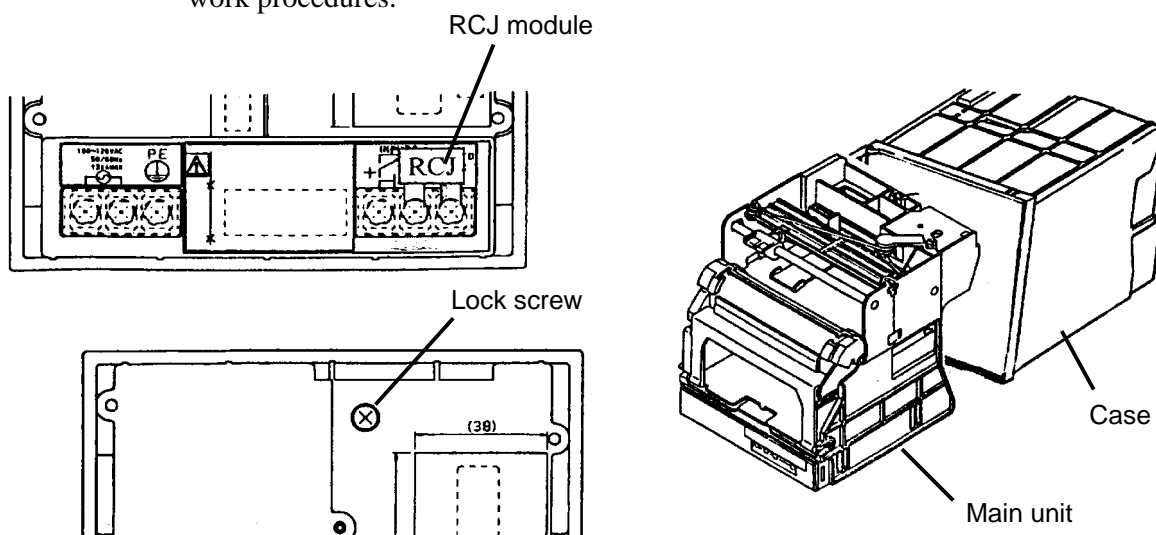

(2) 6-dot type

On the 6-dot type, the main unit need not be drawn out.

- ① Turn OFF the input power for the recorder.
- ② Remove the screws (3 pcs) holding the input terminal unit, then remove the terminal unit.
- ③ Set the setting pin on the interface board referring to Fig. 3.1 “Pin setting specifications”.
- ④ When the setting is finished, return the terminal unit to the original position by reversing the above work procedures.

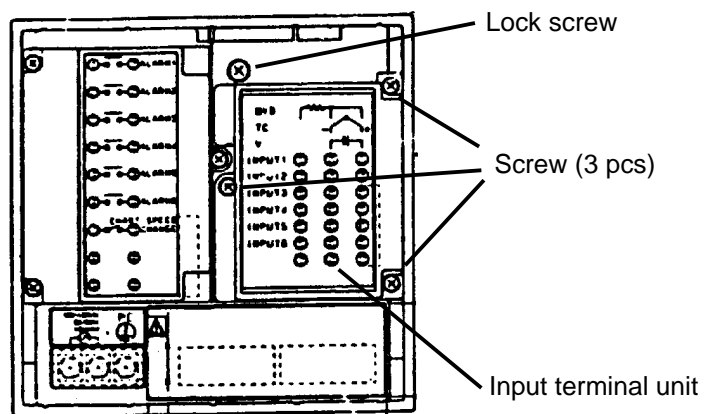

Setting pin position

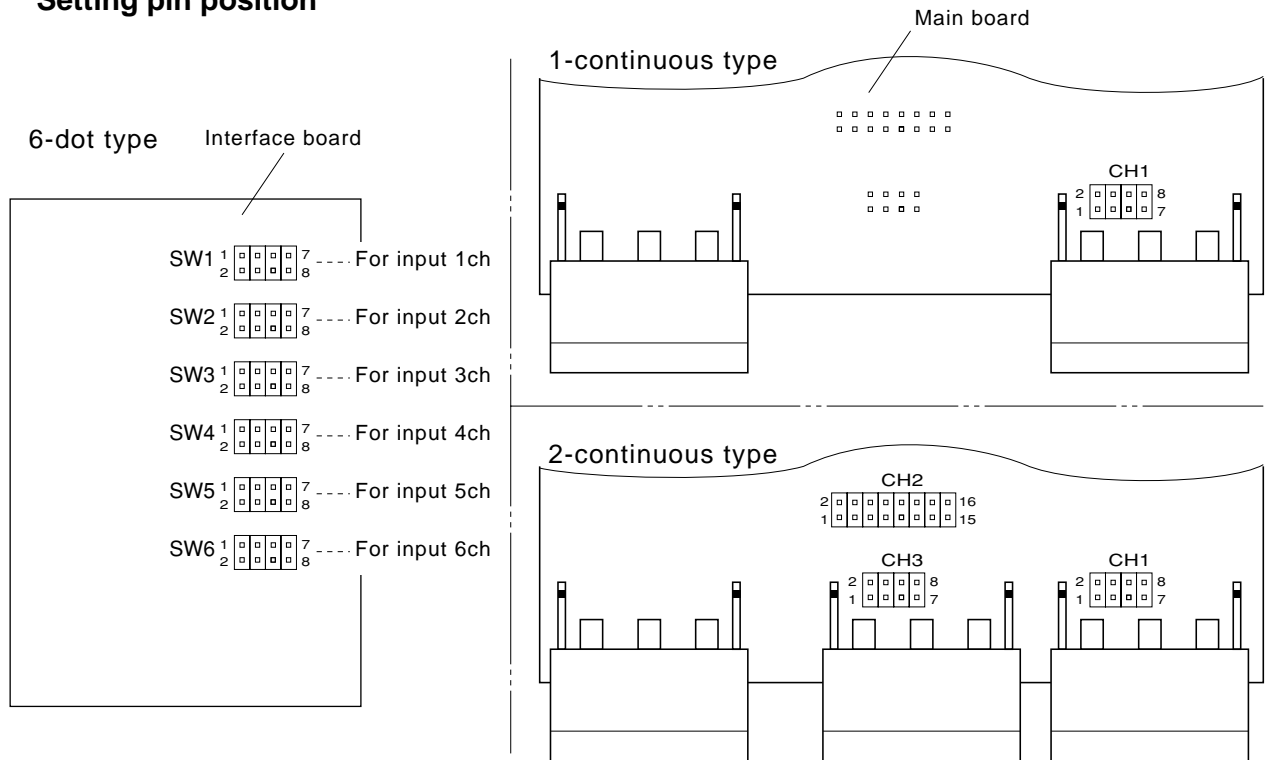

Input type and pin setting : Short-circuit pin

Type Pin setting Input type	1-continuous and 2-continuous type			6-dot type	
	For input 1ch	For input 2ch		For input 1ch to 6ch	
	CH1	CH2	CH3	@ CH1	SW1~SW6
Thermocouple TC		$\begin{matrix} 2 & \square & \square & \square & \square & 16 \\ 1 & \blacksquare & \square & \square & \square & 15 \end{matrix}$	$\begin{matrix} 2 & \square & \square & \blacksquare & 8 \\ 1 & \square & \square & \blacksquare & 7 \end{matrix}$		
Resistance bulb RTD	$\begin{matrix} 2 & \square & \square & \square & \blacksquare & 8 \\ 1 & \square & \square & \square & \square & 7 \end{matrix}$	$\begin{matrix} 2 & \blacksquare & \square & \square & \square & 16 \\ 1 & \blacksquare & \square & \square & \square & 15 \end{matrix}$	$\begin{matrix} 2 & \square & \blacksquare & \square & 8 \\ 1 & \square & \blacksquare & \square & 7 \end{matrix}$		$\begin{matrix} 1 & \square & \square & \square & \blacksquare & 7 \\ 2 & \square & \square & \square & \square & 8 \end{matrix}$
$\pm 50\text{mV}$		$\begin{matrix} 2 & \square & \square & \blacksquare & \square & 16 \\ 1 & \square & \square & \blacksquare & \square & 15 \end{matrix}$			
$\pm 500\text{mV}$ (4 to 20mA)	$\begin{matrix} 2 & \blacksquare & \square & \square & \square & 8 \\ 1 & \blacksquare & \square & \square & \square & 7 \end{matrix}$	$\begin{matrix} 2 & \square & \square & \blacksquare & \square & 16 \\ 1 & \square & \square & \blacksquare & \square & 15 \end{matrix}$			$\begin{matrix} 1 & \blacksquare & \square & \square & \square & 7 \\ 2 & \blacksquare & \square & \square & \square & 8 \end{matrix}$
$\pm 5\text{V}$	$\begin{matrix} 2 & \square & \square & \square & \square & 8 \\ 1 & \square & \square & \square & \blacksquare & 7 \end{matrix}$	$\begin{matrix} 2 & \square & \square & \blacksquare & \square & 16 \\ 1 & \square & \square & \blacksquare & \square & 15 \end{matrix}$	$\begin{matrix} 2 & \square & \square & \square & \blacksquare & 8 \\ 1 & \square & \square & \square & \square & 7 \end{matrix}$		$\begin{matrix} 1 & \square & \square & \square & \square & 7 \\ 2 & \square & \square & \square & \blacksquare & 8 \end{matrix}$
$\pm 50\text{V}$	$\begin{matrix} 2 & \square & \square & \square & \square & 8 \\ 1 & \square & \square & \square & \blacksquare & 7 \end{matrix}$	$\begin{matrix} 2 & \square & \square & \blacksquare & \square & 16 \\ 1 & \square & \square & \blacksquare & \square & 15 \end{matrix}$			$\begin{matrix} 1 & \square & \square & \square & \square & 7 \\ 2 & \square & \square & \square & \blacksquare & 8 \end{matrix}$

Fig. 3.1 Pin setting specifications

3.1.2 Input type setting (front key-board)

The type of input of each channel can be set from the front key-board. When the setting of input type is changed from an input type to a different type, for example, from a thermocouple to a resistance bulb or from $\pm 50\text{mV}$ input to 500mV input, set the input type from the front key-board and then calibrate the input of the channel that has been changed. When an input is changed between the same types, for example, from K-thermocouple to T-thermocouple or from Pt100 to JPt100, the input calibration is not required. For details of input calibration, refer to Item 3.3 “Calibration of measured value” in this manual or “Calibration mode” in the instruction manual.



- When the input type setting is completed, be sure to reset the main unit or turn ON the power again (the main unit can be reset by pressing the reset switch on the front key-board).

The table below shows a list of input types and their displays.

Table 3.1 Input type and display

No.	Display	Input type classification
1	K	K-thermocouple
2	E	E-thermocouple
3	J	J-thermocouple
4	T	T-thermocouple
5	R	R-thermocouple
6	S	S-thermocouple
7	B	B-thermocouple
8	N	N-thermocouple

No.	Display	Input type classification
17	5V	5V
18	50V	50V
19	50mV S	50mV scaling ON
20	500mV S	500mV scaling ON
21	5V S	5V scaling ON
22	50V S	50V scaling ON

No.	Display	Input type classification
9	W	W-thermocouple
10	L	L-thermocouple
11	U	U-thermocouple
12	Pn	Pn-thermocouple
13	Pt100	Pt100
14	JPt100	JPt100
15	50mV	50mV
16	500mV	500mV

(1) Case of thermocouple and resistance bulb

- Setting of input type and temperature unit (°C or °F)

<Example>

Setting of Ch1 to °C with K-thermocouple (Range setting is mentioned in Item 3.2)

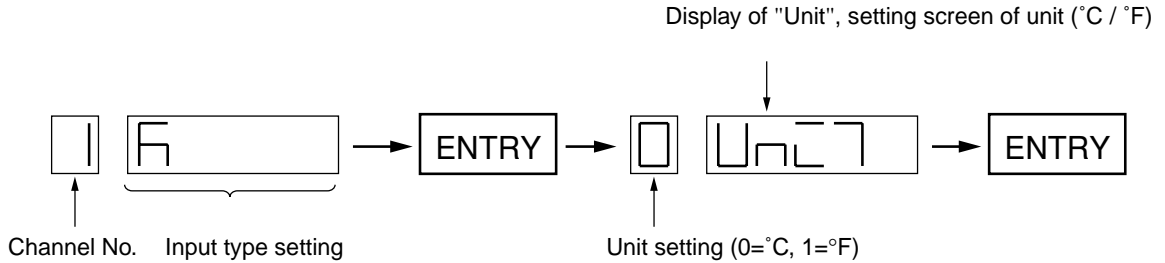

(2) Without voltage input scaling

<Example>

Ch1 is set to ±500mV range.

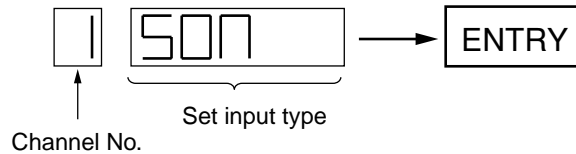

(3) With voltage input scaling (ON)

When the scaling is ON with voltage input, the measurement range, decimal point position and industrial value can be set.

<Example>

Ch1 is set to ±5V range, scaling ON, and measurement range 0 to 1V (decimal point position has been determined by the input range beforehand and is fixed at that position).

Industrial value after scaling: 0.0 to 100.0 Displayed down to the first digit below the decimal point.

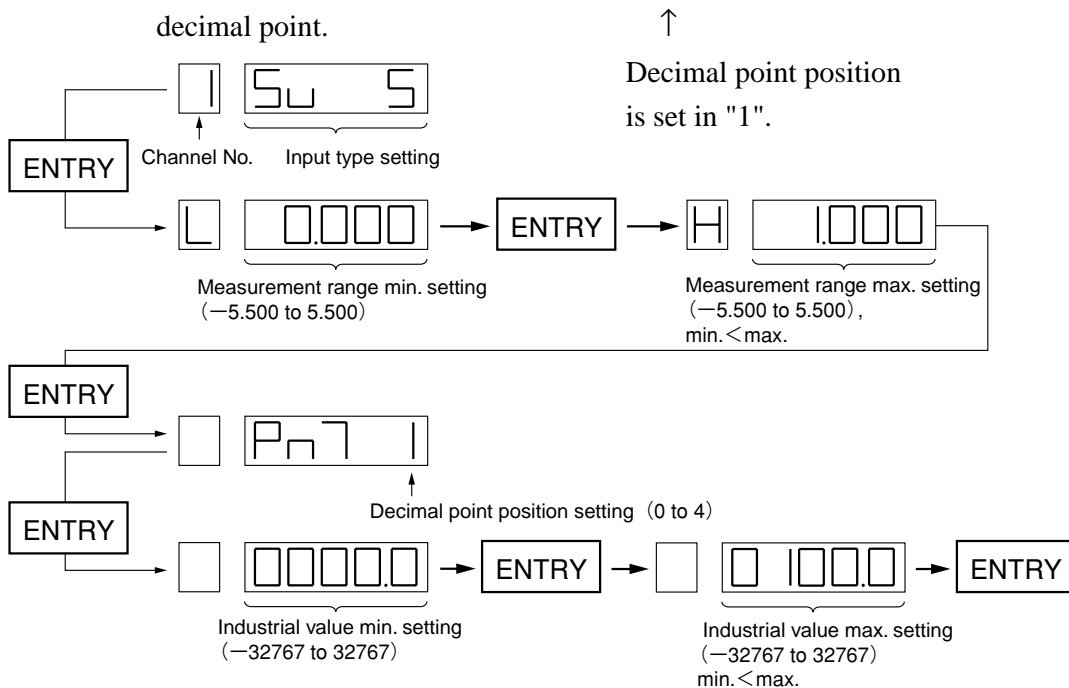

3.2 Recording range setting

- Set the recording range of each channel.
- For the setting range, refer to Table 3.2 "Setting range of recording range".

<Example>

Ch1 recording range is set to 0.0 to 100.0.

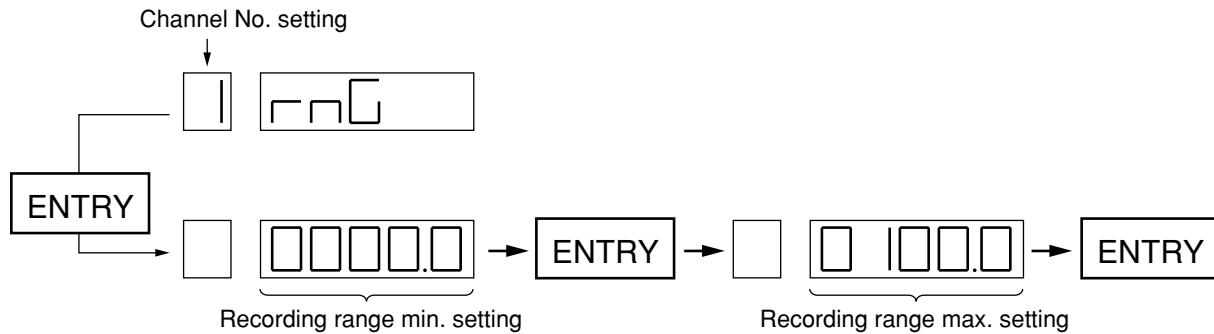

Table 3.2 Setting range of recording range

Display		°C	°F
Thermocouple	B	370.0 to 1790.0°C	698.0 to 3254.0°F
	R	-30.0 to 1790.0°C	-22.0 to 3254.0°F
	S	-30.0 to 1790.0°C	-22.0 to 3254.0°F
	K	-230.0 to 1400.0°C	-382.0 to 2552.0°F
	E	-230.0 to 830.0°C	-382.0 to 1526.0°F
	J	-230.0 to 1130.0°C	-382.0 to 2066.0°F
	T	-230.0 to 430.0°C	-382.0 to 806.0°F
	N	-30 to 1330.0°C	-22.0 to 2426.0°F
	W	-30 to 1790.0°C	-22.0 to 3254.0°F
	L	-230.0 to 930.0°C	-382.0 to 1706.0°F
	U	-230.0 to 430.0°C	-382.0 to 806.0°F
Resistance bulb	Pt100	-230.0 to 630.0°C	-382.0 to 1166.0°F
	JPt100	-230.0 to 630.0°C	-382.0 to 1166.0°F
DC voltage	±50MV	-55.00 to 55.00mV	
	±500MV	-550.0 to 550.0mV	
	±5V	-5.500 to 5.500V	
	±50V	-55.00 to 55.00V	
	Scaling ON	Industrial value -32767 to 32767 (decimal point is optional)	



- When the setting of recording range is finished, be sure to reset the main unit or turn ON the power again (the main unit can be reset by pressing the reset switch on the front key-board).

<Supplement> Recording range setting

When only the recording range is changed without changing the input type (for example, from thermocouple to resistance bulb or from $\pm 50\text{mV}$ to $\pm 500\text{mV}$), the measured value need not be calibrated.

<Example ... Case where calibration of measured value is not required>

- Input was changed from K-thermocouple to T-thermocouple in the same group of thermocouple and the input range (recording range) was changed from “0 to 200°C” to “0 to 300°C”. ... Input calibration is not required.
- Input was changed from JPt100 to Pt100 in the same group of resistance bulb and the input range (recording range) was changed from “0 to 300°C” to “0 to 500°C”. ... Input calibration is not required.
- At $\pm 5\text{V}$ of input, the input range was changed from “0 to 5V” to “1 to 5V” Input calibration is not required.
- The input was changed from $\pm 5\text{V}$ to $\pm 5\text{V}$ scaling ON and the input range was changed from 0 to 5V to 1 to 5V. Also, the industrial value after scaling was changed to 0.0 to 100.0%....Input calibration is not required.

(When the recording range has been changed, be sure to reset the main unit or turn ON the power again)

3.3 Calibration of measured value

When the setting of input type has been changed, be sure to calibrate the measured value.

<Pin setting for input type → Input setting from the front key-board → Recording range setting from the front key-board → Calibration of measured value> ... Carry out the above-mentioned items.

<Pin setting for input type → Input setting from the front key-board → Calibration of measured value> ...Calibration can be made normally even after the above-mentioned items have been carried out, but it is better for you to carry out the setting of recording range in advance (the setting method is also mentioned in the instruction manual).

- Operation -

- ① Press the RECORD key to stop the recording operation.
- ② Press the DISPLAY key for 3 seconds to display the setting mode (Key Lock display).
- ③ While pressing the UP key, press the SELECT key for 3 seconds. The display is shifted to the adjustment mode.

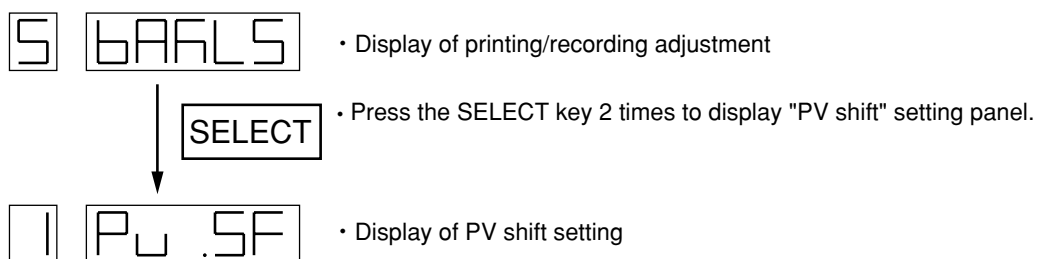

- ④ While pressing the UP key, press the SELECT key for 3 seconds. The display is shifted to the calibration mode.

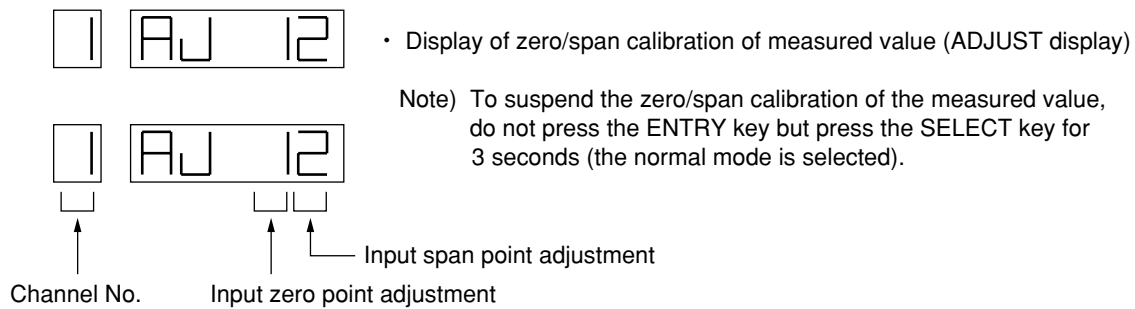

- ⑤ Press the UP key and select a channel for calibration. Ch1 to Ch6 = DC voltage input, resistance bulb input, thermocouple input



CAUTION • Ch7, Ch8 = Used for maker's test. Never use these channels.

- ⑥ After the channel for calibration is selected, press the ENTRY key.

- ⑦ Apply 0% input. *1

*1 The input signal for 0% point calibration is shown below.

Voltage input:	0mV or 0V
Thermocouple input:	0V
Resistance bulb (Pt or JPt):	100Ω

- ⑧ After the 0% input is applied, press the ENTRY key. Zero calibration is automatically started.

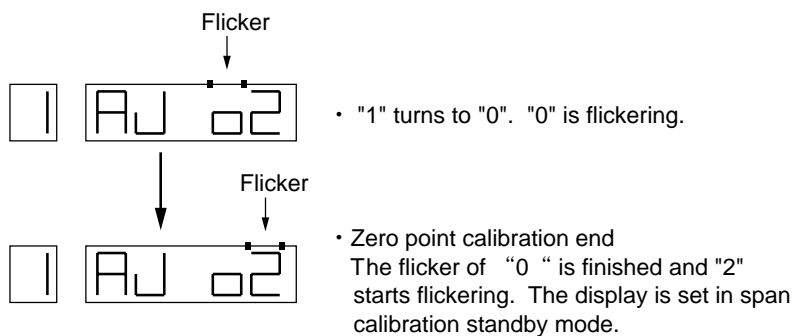

- ⑨ Apply 100% input. *2

*2 The input signal for 100% point calibration is shown below.

± 50mV:	50mV
± 500mV:	500mV
± 5V:	5V
± 50V:	50V
Thermocouple input:	50mV (room temperature compensation not required)
Resistance bulb (Pt or JPt):	324.26Ω

- ⑩ After the 100% input is applied, press the ENTRY key. Span calibration is automatically started.

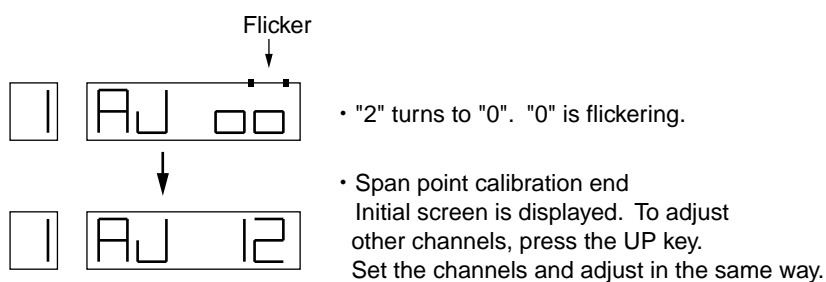

- ⑪ Press the SELECT key for 3 seconds. The display mode is selected and the calibration is finished.

Note) When a channel No. has been selected, calibration can not be suspended by the SELECT key until the calibration is finished.

To suspend the calibration, turn ON the power again or press the reset button.

3.4 Industrial unit setting

- For unit symbol (character) setting, one character should be set with 2 codes (No.1 and No.2 codes).
- Unit symbol of each channel can be set in maximum 7 characters.
- Setting of unit symbol character positions (digits) are shown below.

<Example>

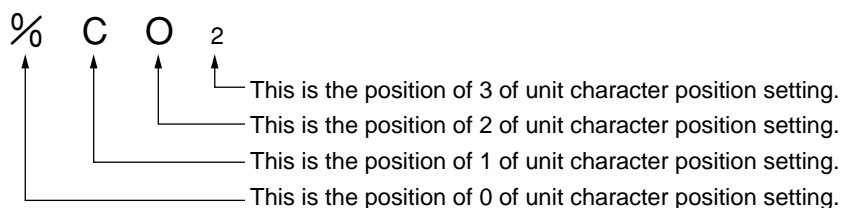

Table 3.4 Unit symbol (character) setting code

No.1 code \ No.2 code	2	3	4	5	6	7	8	9	A	B	C	D	E	F
0	SP	0	@	P	\	p	↑			—	タ	ミ	2	
1	!	1	A	Q	a	q	↓			ア	チ	ム	3	
2	ˆ	2	B	R	b	r	←			イ	ツ	メ		
3	#	3	C	S	c	s	→			ウ	テ	モ		
4	\$	4	D	T	d	t				エ	ト	ヤ		
5	%	5	E	U	e	u			・	オ	ナ	ユ		
6	&	6	F	V	f	v			ヲ	カ	ニ	ヨ		
7	'	7	G	W	g	w			ァ	キ	ヌ	ラ		
8	(8	H	X	h	x	⁻¹	μ	ィ	ク	ネ	リ		
9)	9	I	Y	i	y	²		ゥ	ケ	ノ	ル		
A	*	:	J	Z	j	z	³		ェ	コ	ハ	レ		
B	+	;	K	[k	{	⁰		ォ	サ	ヒ	ロ		
C	,	<	L	¥	l				ャ	シ	フ	ワ		
D	—	=	M]	m	}			ュ	ス	ヘ	ン		
E	.	>	N	^	n	~			ョ	セ	ホ	ˆ		
F	/	?	O	_	o	■	Ω		ッ	ソ	マ	。		

Note) In the above table, SP (Code 20) means "Space" which is set as a blank column without character. Do not use the blank columns in this table.

- Unit symbol setting method

Display the setting screen of industrial unit of "System parameter setting mode".

Industrial unit setting screen

The displayed figure 56 is a unit code No. that is set at present. The code No. is not always 56 (the code No. being set is displayed).



<Example>

Setting of %CO₂

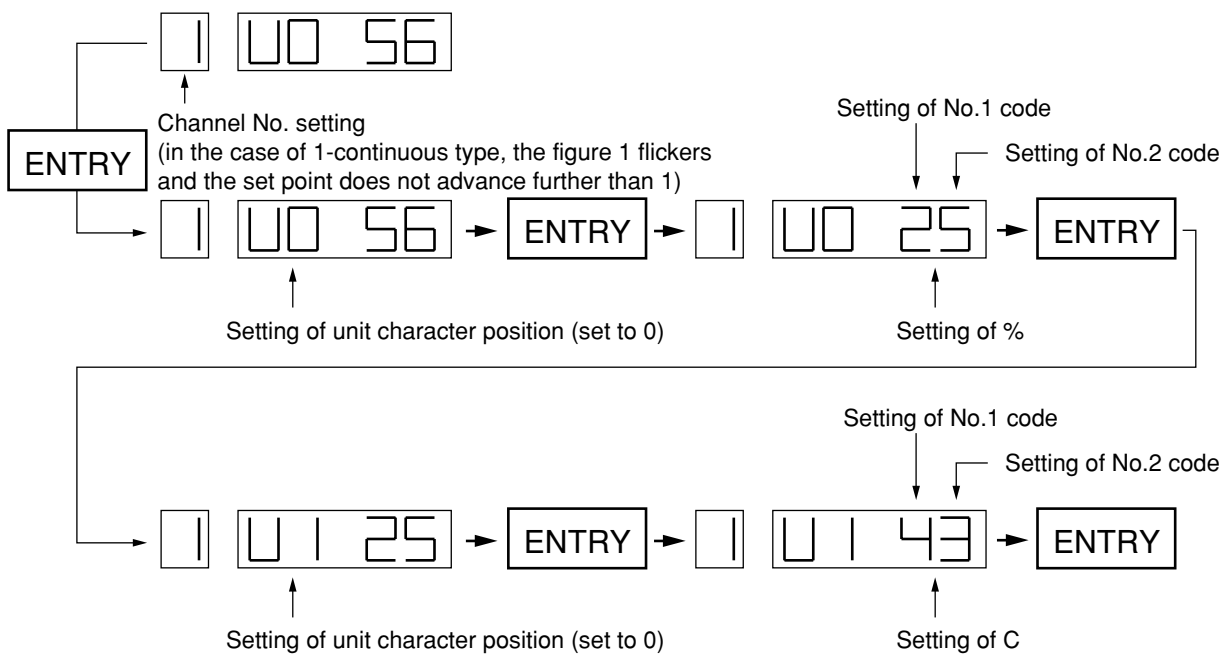

Set O and 2 in the same way.



- When the setting of this industrial unit is finished, be sure to reset the main unit or turn ON the power again. (The main unit can be reset by pressing the reset switch on the front key-board)

3.5 Channel No. print function OFF

Channel No. cannot be printed on the recording line by setting this function.

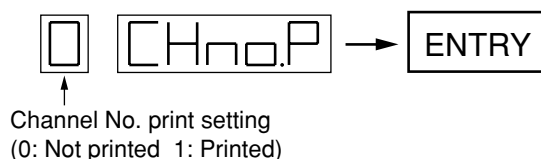

- When the setting of channel No. print function OFF is finished, be sure to reset the main unit or turn ON the power again. (The main unit can be reset by pressing the reset switch on the front key-board)

3.6 Reference contact compensation function (RCJ) OFF

When the input is thermocouple, the function of reference contact compensation can be disabled by setting this function.

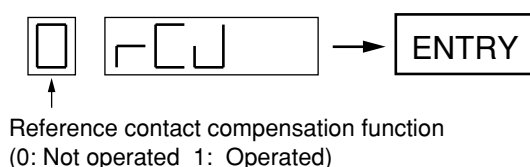

- When the setting of reference contact compensation function (RCJ) OFF is finished, be sure to reset the main unit or turn ON the power again. (The main unit can be reset by pressing the reset switch on the front key-board)

3.7 Setting of print-out intervals of periodic print-out and scale print-out

Normal print-out interval is set automatically by the chart paper feed speed. It can also be set in optional values.

- Method of setting optional print space

- ① Set the print-out interval for periodic print-out to "1".
(0: Set by chart paper feed speed 1: Set as desired)
 - ② When the print-out interval is set to "1", the operation mode returns to "Normal mode" from "System parameter setting mode".
 - ③ The operation mode is shifted from "Normal mode" to "Setting mode".
 - ④ When the periodic print-out ON/OFF setting screen of "Setting mode" is displayed, press the ENTRY key and "Print-out interval setting" screen will be displayed.
(Under normal conditions, this screen is not displayed. It can be displayed by setting "Print-out interval setting" of "System parameter setting mode" to "1")
- Print-out interval can be set from 0 to 255 (Unit time: Minute).
 - 0: Print-out interval is 12 hours.
 - 1 to 255 (Unit time: Minute): Print-out interval is 2 times the set value.

<Example>

When the print-out interval is set to 10, it becomes 20 minutes.

<Example>

Setting of print-out interval for periodic print-out to 20 minutes

Set to "1" by "Setting of print-out interval for periodic print-out" of "System parameter setting mode".

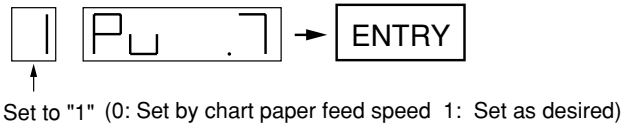

Display the setting screen "Periodic print-out ON/OFF" of "Setting mode".

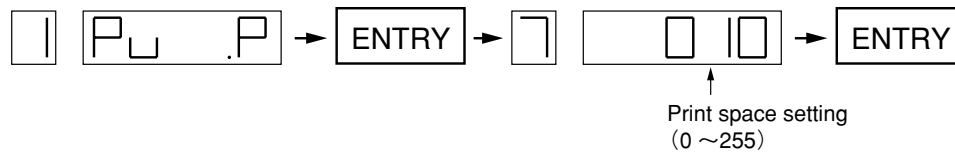

- When the setting of print-out interval for periodic print-out and scale print-out is finished, be sure to reset the main unit or turn ON the power again. (The main unit can be reset by pressing the reset switch on the front key-board)

3.8 Setting of external contact input (DI) function

Besides normal function for "Chart paper feed speed selection", a function for "Measurement print-out" can be set by external contact input (DI).

(When this function is used, the chart paper feed speed cannot be selected)

- DI function setting method (allocation)

	PA setting	Pb setting
Standard function (chart paper feed speed selection)	0	0
Measurement print-out	1	0
Used for maker. Do not use.	0	1
	1	1

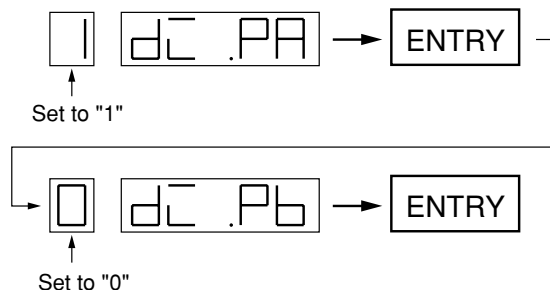

- When the setting of external contact input (DI) function is finished, be sure to reset the main unit or turn ON the power again. (The main unit can be reset by pressing the reset switch on the front key-board)

3.9 Alarm print-out function OFF

Alarm generation/release print-out can be set not to be burnt out.

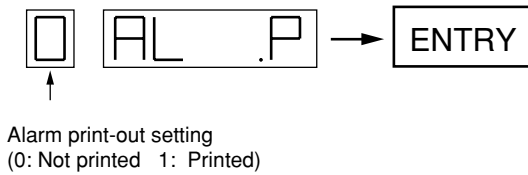

- When the setting of alarm print-out function OFF is finished, be sure to reset the main unit or turn ON the power again. (The main unit can be reset by pressing the reset switch on the front key-board)

APPENDIX 3. CHANGE OF HARDWARE

• How to perform switching between 100V and 200V



- Be sure to turn OFF the power before starting the work.

• Case of 1- or 2-continuous type

Step 1

Remove the reference contact compensation module (RCJ module) [(1) shown in figure] for thermocouple and shunt resistance of 4 to 20mA input [(2) shown in figure], if provided.

If alarm & external control unit [(3) shown in figure] is provided, dismantle the unit after removing three fixing screws [(4) shown in figure].

(If power supply wiring [(5) shown in figure] and input terminal wiring [(6) shown in figure] are laid, remove these wires.)

• Case of 6- dots type

Dismount the input terminal [(7) shown in figure] after removing three fixing screws [(8) shown in figure].

If alarm & external control unit [(3) shown in figure] is provided, dismantle the unit after removing three fixing screws [(4) shown in figure].

(If power supply wiring [(5) shown in figure] are laid, remove these wires.)

Step 2

Remove one lock screw [(9) shown in figure], which is fixing the main unit to the case.

Step 3

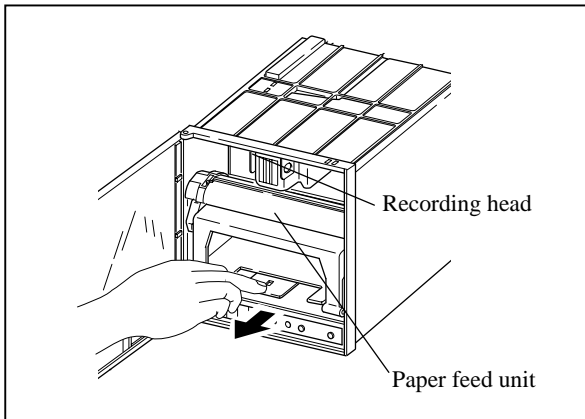

Open the front door. Push down the paper feed unit draw-out lever, and pull and take out the paper feed unit.

Take out the recording head from the main unit.

Step 4

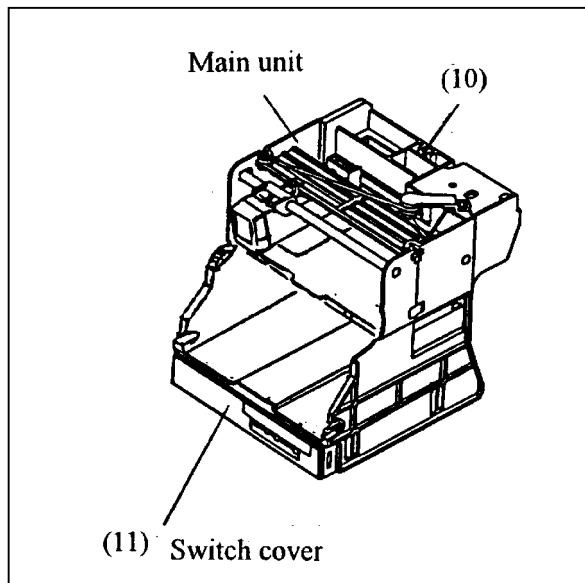

Pull and take out the main unit from the case.

Take out the nut [(10) shown in figure], which is fitted to the main unit, at this time and store it.

Dismount the switch cover [(11) shown in figure] located in the lower part of the front face of the main unit.

Step 5

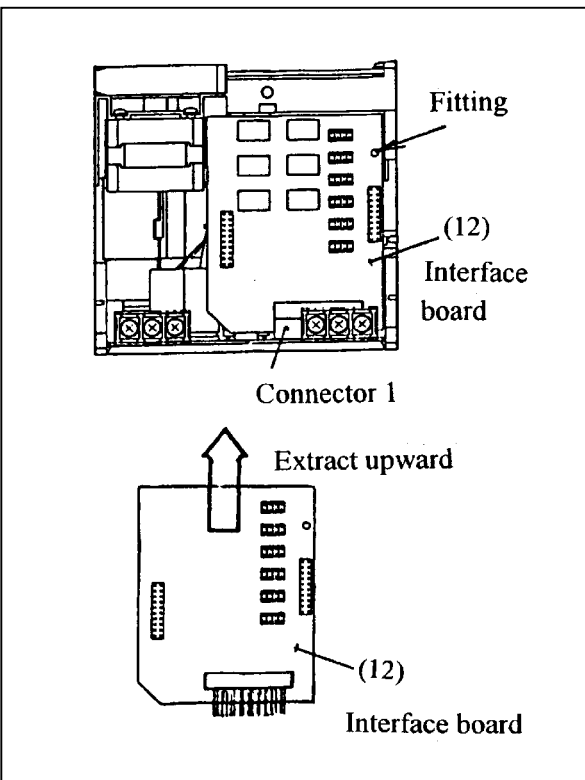

If an interface board [(12) shown in figure] is provided, dismount it in the sequence indicated below.

(1) Disengage the fitting of the printed circuit board at the upper right portion of the interface board.

(Disengage the fitting by expanding the point of the main unit shown on the left.)

(2) Dismount the interface board from connector 1 (by extracting upward).

Step 6

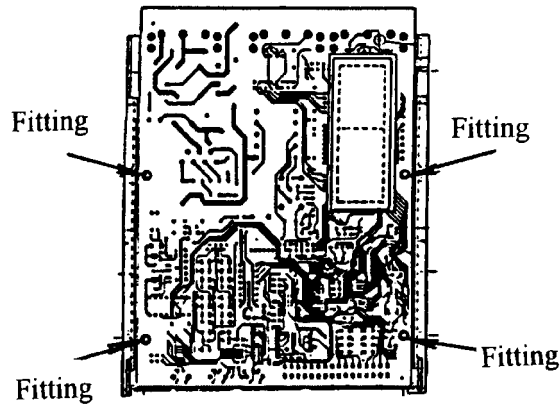

Reverse the main unit so that the printed circuit board at the bottom faces upward.

Then disengage the fittings at four places of the printed circuit board.

(Disengage the fitting by expanding the portion located by each fitting.)

Step 7

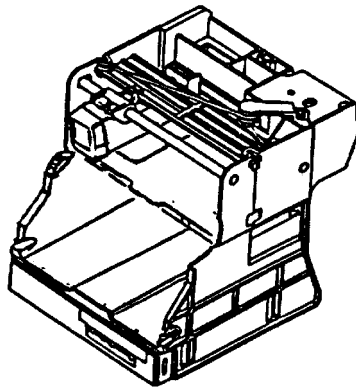

Return the main unit to the former state while holding the printed circuit board by hand so that it will not drop.

Move the main unit to a forward position of the printed circuit board so that the work of replacement of the main board can be easily performed.

Step 8 Change connection of the jumper wire using a soldering iron.

100V system [100, 115, 120V AC]: Shorting between A and B ... Short using a jumper wire.

200V system [200, 220, 240V AC]: Open between A and B No jumper wire.

Use crosslinked-polyethylene wire of 0.5 mm as the shorting wire.

100V system: Shorting between A and B

200V system: Open between A and B

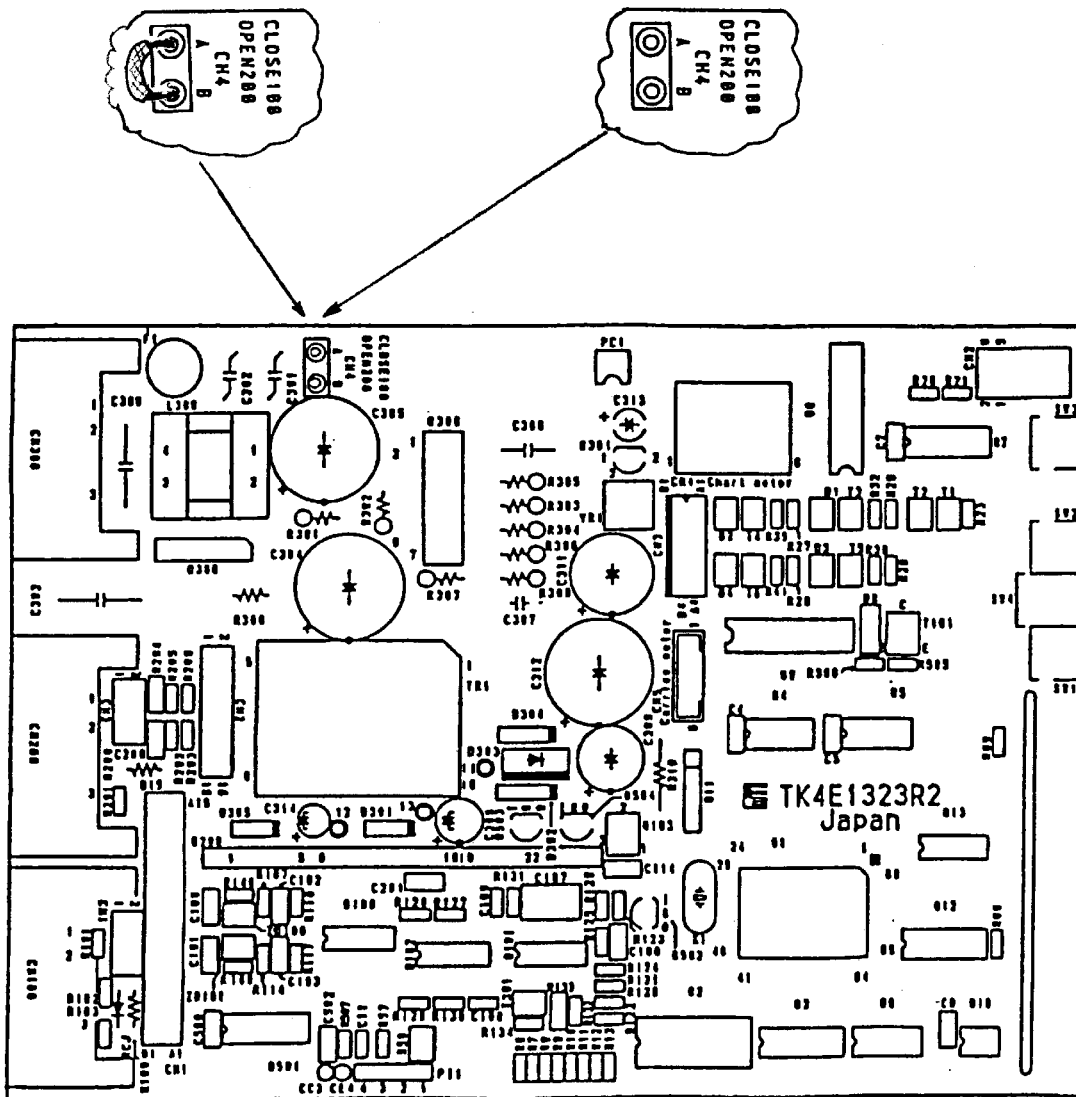

Step 9

Return to the original state by performing the works described above in the reverse sequence.