

**Remote manual and auto/manual loading stations are designed for the remote control of pneumatic systems using a manostat regulator and different combinations of air switching valve and pressure gauge.**

- Reliable, durable
- Visual display of set pressure
- Precise regulation
- Excellent setting sensitivity

**TYPICAL APPLICATIONS**

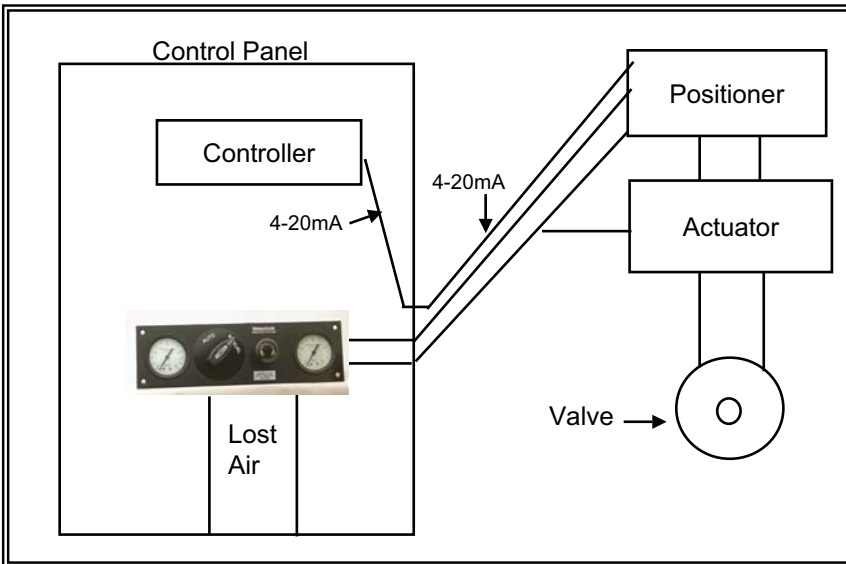
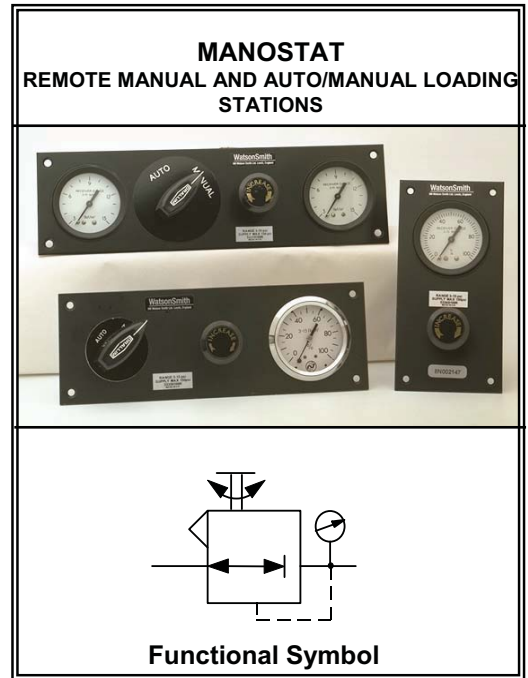

**Industry:**

Used in thousands of applications worldwide, Watson Smith Instrumentation Pressure Regulators have unparalleled accuracy and stability regardless of input pressure and flow fluctuations and are ideal for dead-end applications.

**Solution:**

Designed for the remote control of pneumatic systems, the loading stations use an R27 and different combinations of air switching valves and pressure gauges.

Available as remote manual and auto/manual loading stations



## **TECHNICAL DATA**

### **Pneumatic**

- Output Signal See ordering information. Minimum outlet pressure 0.1-0.14bar (1.5-2psig)
- Air Supply Oil free, dry air or other dry gases, filtered to better than 25 microns; at least 0.2bar (3psig) above output pressure to a maximum of 10bar (150psig, 1000kPa)
- Flow Capacity Up to 300NI/min (10scfm).
- Air Consumption 0.2 l/min (0.006scfm) at 1bar (15psig);  
0.3 l/min (0.01scfm) at 1.7bar (25psig);  
0.6 l/min (0.02scfm) at 4bar (60psig);  
1.2 l/min (0.04scfm) at 8bar (120psig) (typical values at maximum supply pressure)
- Response Time less than 0.2 seconds for 50% load change
- Regulation % output change for 1bar/15psi supply Accuracy pressure change at mid-range output:  
0.1% (0.14bar/2-25psi), 0.05% (0.14-4bar/2- 60psi), 0.02% (0.14-8bar/2-120psi)
- Sensitivity Better than 0.3mbar (0.005psi)
- Hysteresis Typically less than 0.05% setting at mid-Repeatability range
- Temperature Effect Typically better than  $\pm 1\%$  change of full span between 20°C and +70°C
- Connections 1/4" NPT female standard (plus two integral 1/4" NPT gauge ports);  
others available on request

### **Physical**

- Operating Temperature -20°C to +70°C
- I.P. Rating IP65
- Vibration The unit is unaffected by moderate vibration
- Material of Construction Zinc diecasting passivated and epoxy painted, Beryllium copper capsule;  
Nitrile diaphragms

**Note:** A small positive pressure (<2psig, 0.14bar) will always be shown at the lower end of the gauge scale (due to regulator servo operation)

### **Model Types**

(With panel mounting plate, 3mm thick, black painted finish with corner fixing straps)

- SP Manostat regulator plus 63mm diameter pressure gauge (phosphor bronze Bourdon tube to BS1780); horizontal/vertical mounting
- SP2 As SP model but with a rotary 2 position, 3-way auto/manual valve; horizontal/vertical mounting; pressure gauge indicates manual set pressure only
- SP2G2 As SP2 model but with a second pressure gauge to measure auto signal pressure before switching; horizontal/vertical mounting
- SP2G2W Weatherproof SP2G2; surface/post mounting (yoke supplied suitable for a 50mm/2" diameter post)

## Installation Diagrams

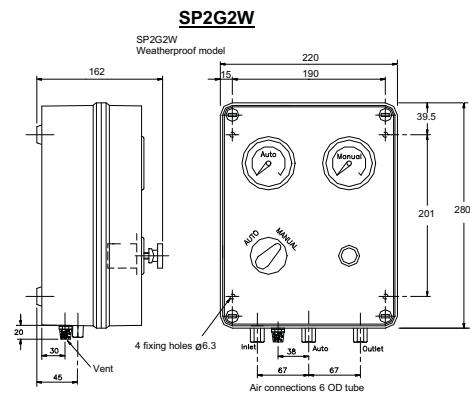
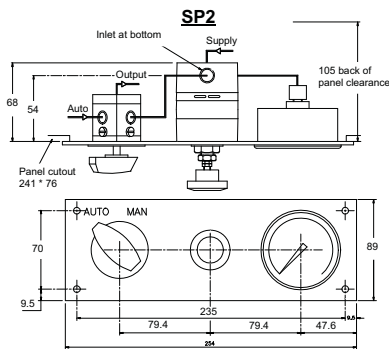
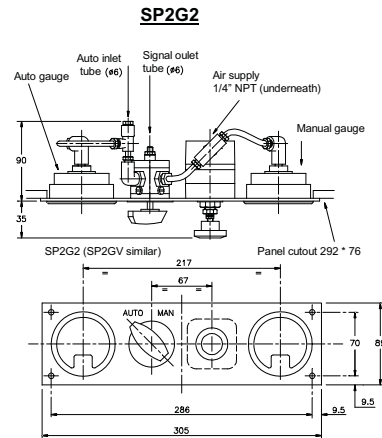
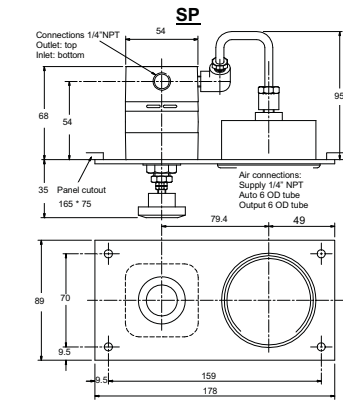

## Ordering Information

Part Number	Description
359000R	SP2H 0.2-1 bar; 0-100%
371201R	SP2G2H : 0.2-1 bar, Captured Bleed
379000R	SP2G2H: 0.2-1bar, 0-100%
382100R	SP2G2V: 0.2-1bar
391200R	SP2G2W: 0-30psi
392100R	SP2G2W: 0.2-1 bar
393200R	SP2G2W: 0-2 bar
399100R	SP2G2W: 3-15psi, 0-100%
399110R	SP2G2: 3-15psi, 0-100% Yoke Mounting

**ORDER CODES:** Each product has a 7-digit code which can be compiled as shown in the table

Options to special order:

- Special scale calibrations
- Alternative pneumatic connections
- Alternative materials of construction
- Feedback available on switches
- Explosion-proof switches

Your distributor:

**Coulton Instrumentation Ltd**  
 17 Somerford Business Park, Christchurch, BH23 3RU, UK  
 Tel: +44 1202 480 303  
 E-mail: sales@coulton.com  
 Web: www.coulton.com

dslstnN 04/07  
 Control Doc. 2006-113a

*All instruments are tested on the Watson Smith Automatic Testing System and an individual test certificate is provided at no extra charge. Each unit is tested for linearity, hysteresis, total error, air consumption, response time and supply sensitivity.*

***Our policy is one of continuous research and development. We therefore reserve the right to amend without notice the specifications given in this document. Customers are responsible for ensuring that the product is used only for the purpose for which it is intended. In case of doubt Norgren will be pleased to advise.***