

SOFT MONITOUCH

TELLUS and V-Server

Make your office the forefront of production

SOFT MONITOUCH TELLUS and V-Server

Monitoring the plant from the office enables quick response to changes, improving operating efficiency.

TELLUS and V-Server links Monitouch in a plant with a PC in the office, so that your PC can collect on-site data or monitor and control the equipment in the plant.

This combination enables efficient and low-cost production; immediate and appropriate responses to the condition of the line is possible from anywhere.

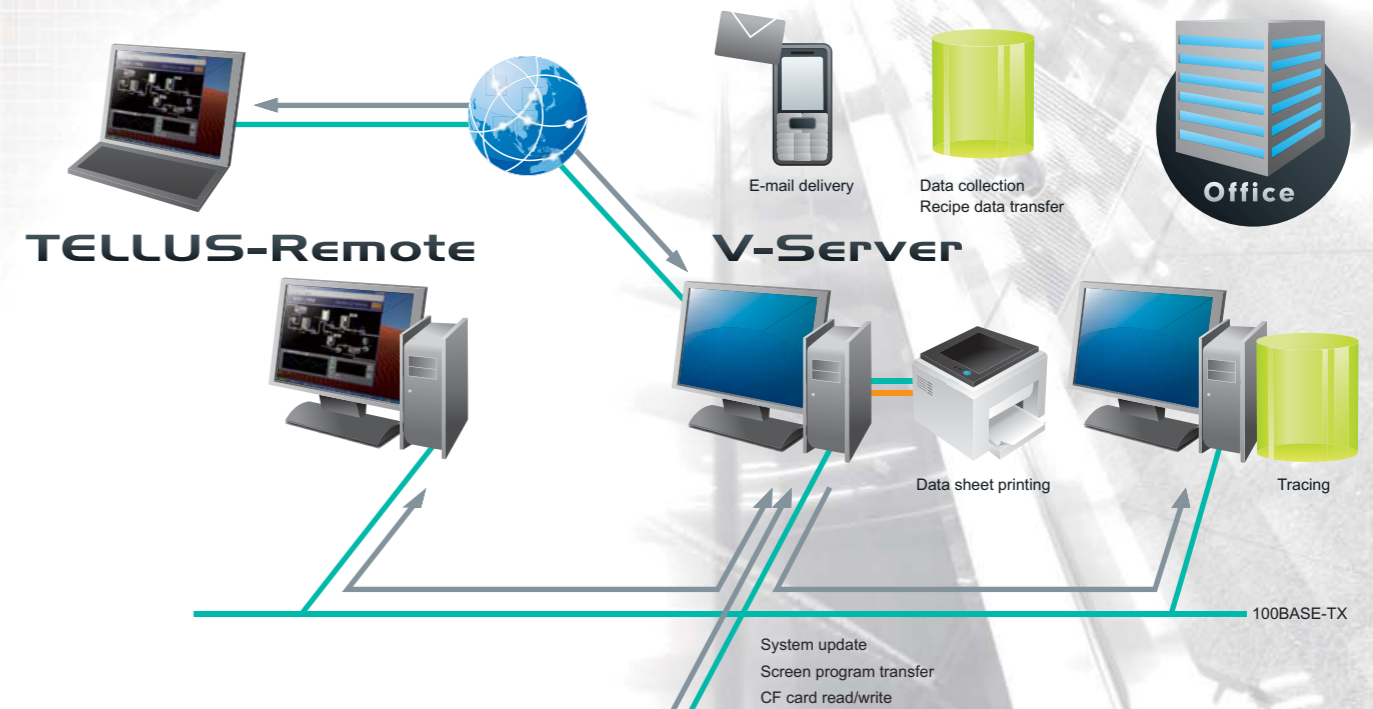

V-Server

P.03

Collection and saving of current data

Linkage of a PC and Monitouch via Ethernet enables collection and saving of on-site data in real time.

TELLUS-Remote

P.05

Remote monitoring and control

Installation of the TELLUS and V-Server software package allows your PC to monitor and control the production site via Monitouch through Ethernet.

TELLUS-HMI

P.06

Monitouch functions available on your PC

Equivalent functions of Monitouch are available on your PC by directly connecting to PLC after installing TELLUS software on your PC. It is possible to display an image of the entire line on a large screen display and link various Windows applications.

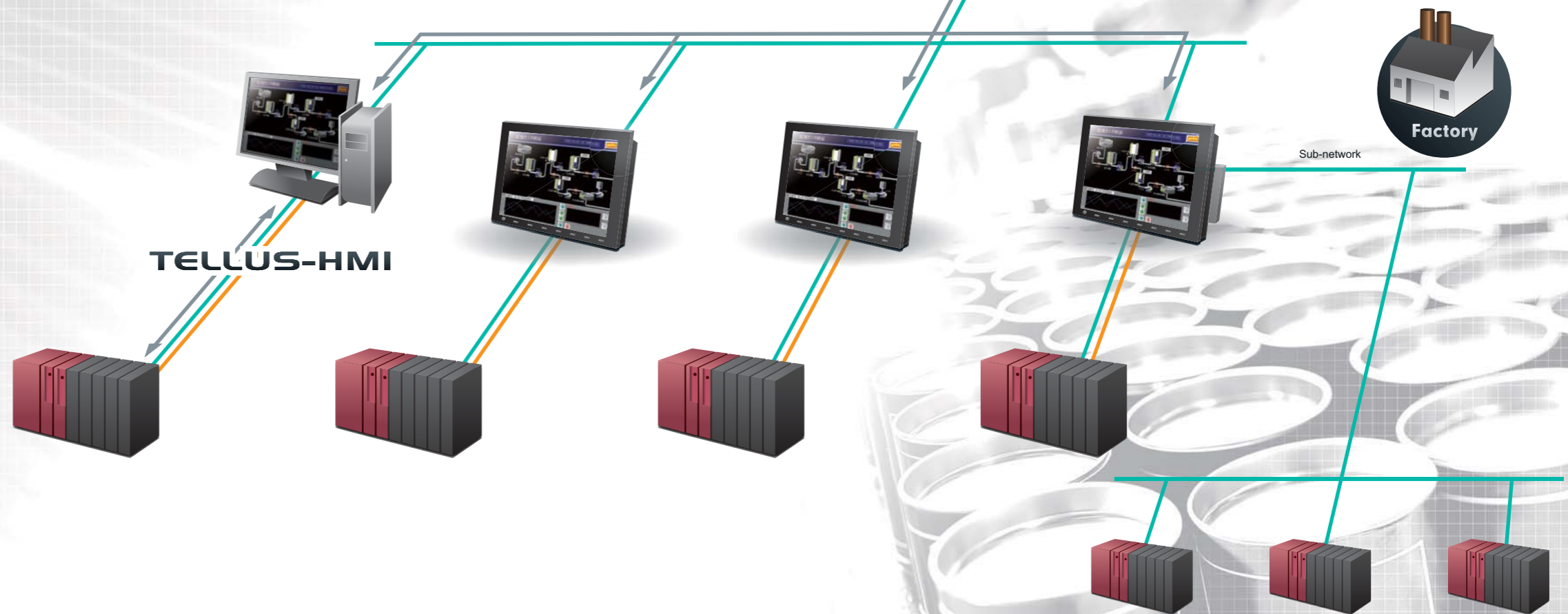
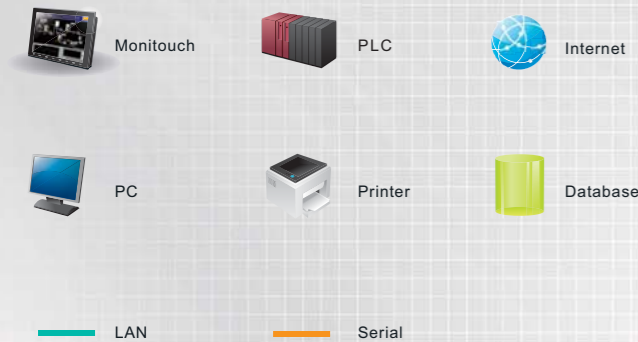

Linking your office and plant for collection of production data

V-SERVER

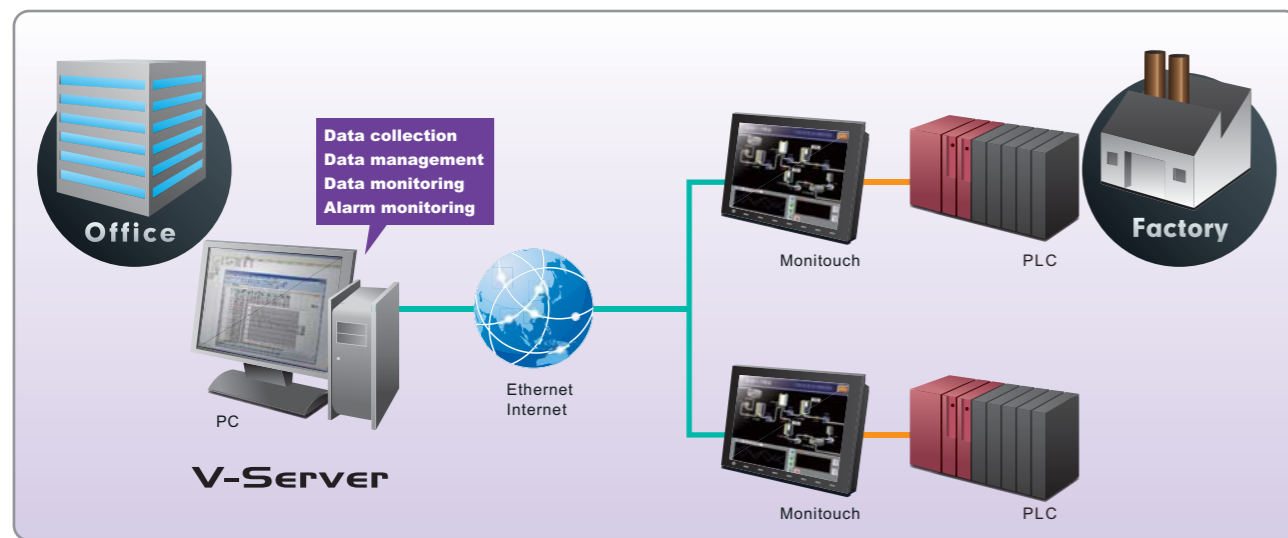

Easy to make daily and monthly reports (DDE function)

The tag data registered in V-Server can be pasted to Excel files in DDE format. This makes it easy to generate daily/monthly reports.

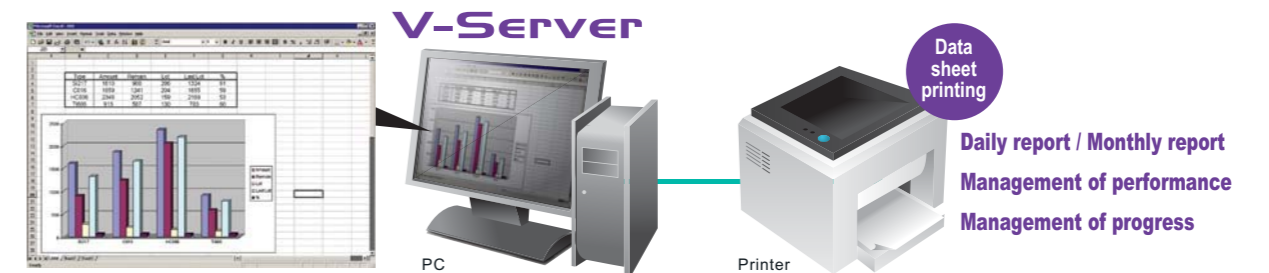

Data saving without programming



Data logging function

Production data can be regularly read out and saved in database or CSV/Excel format.

Readout of sampling data

Sampling data stored in Monitouch can be read out and saved in database or CSV/Excel format.

Consolidated recipe data management

Consolidation of recipe data by the upper-level PC reduces the process of recipe registration and modification for each piece of equipment and provides consistent product quality.

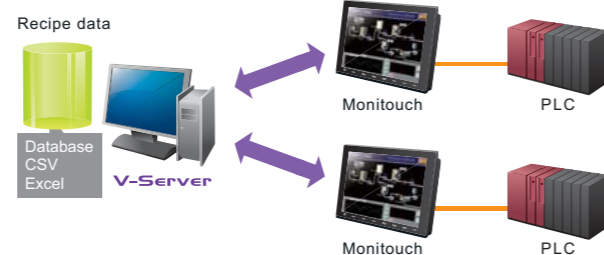

Consolidated management of data of PLCs of various types and manufacturers

V-Server collects information from peripheral devices through Monitouch as a gateway. It is possible to collect information from the devices of any type and manufacturer if they can be connected to Monitouch.

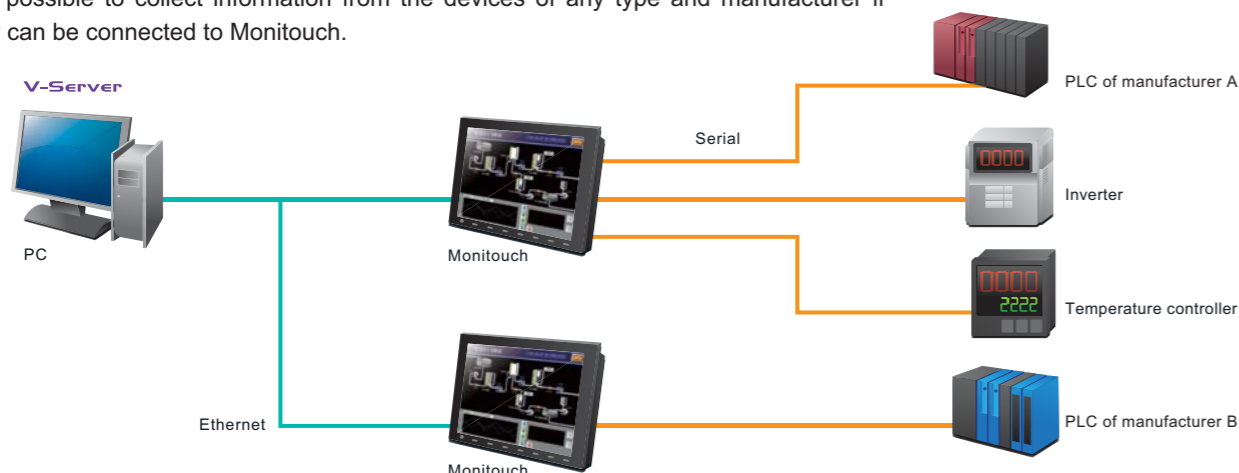

Quick response to on-site problems

Alarm data can be monitored to display historical data or a list of alarms currently occurring. In addition, an e-mail alert can be sent immediately when a critical alarm occurs.



Updating of Monitouch data from the office

You can update the system program of multiple Monitouch panels at a time or transfer the screen program to them all together.

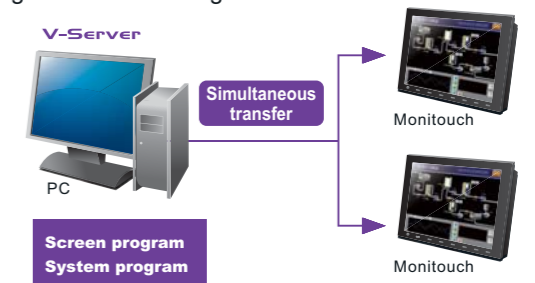

Reading and writing of CF cards

Files on a CF card inserted in Monitouch can be read out to a PC, and files edited on a PC can be written onto a CF card via Ethernet.

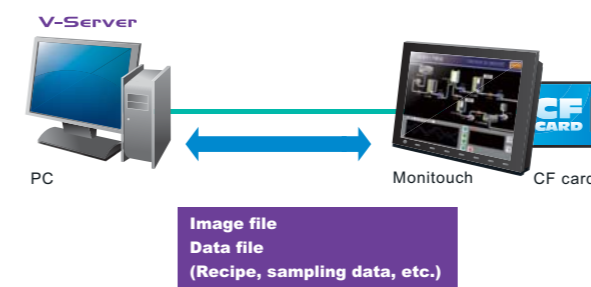

Automatic actions in response to events

Various kinds of events can be set depending on the requirements of the operation. Events allow for a high degree of flexibility, so you can adapt to the specifications of the production line.

Event (Trigger conditions)		
Bit ON/OFF	Setting of memory values	Time setting
Action (Operations)		
Start/Stop of logging	Recipe read/write	Sampling readout
Application start-up	CF card read/write	

Remote monitoring and control TELLUS-Remote

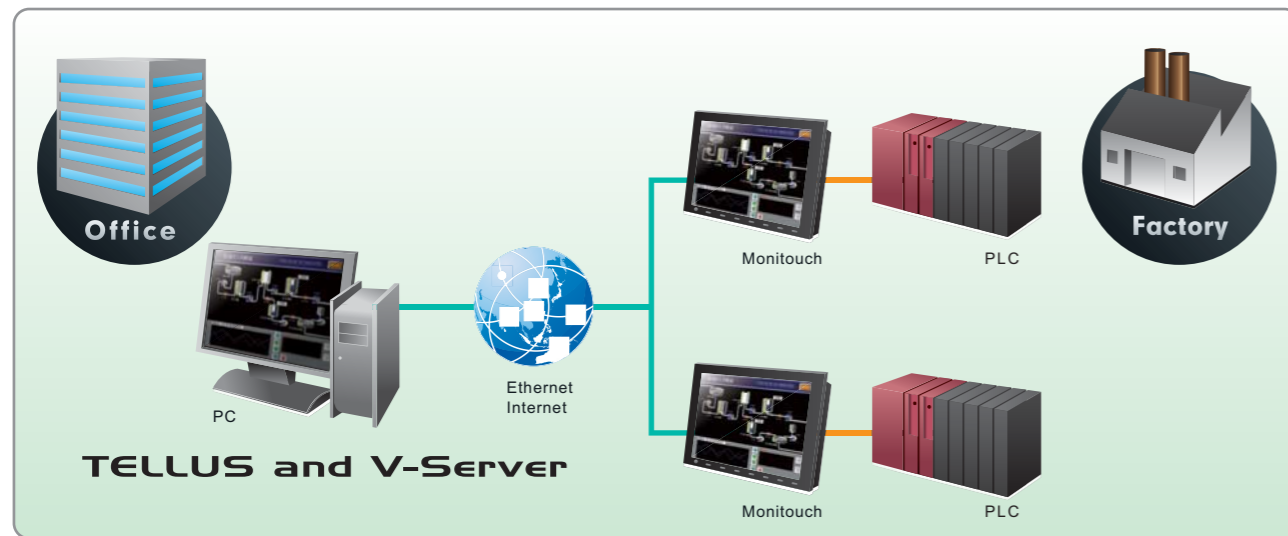

Integration of PC and Monitouch improves performance beyond Monitouch's capacity.

TELLUS-HMI

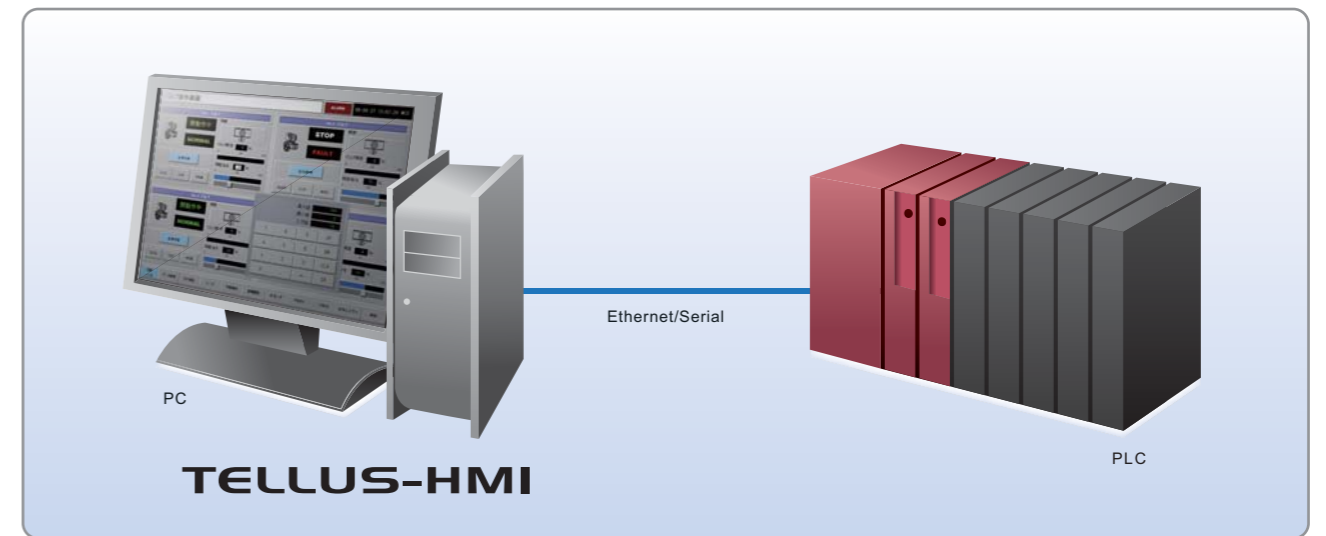

Remote control with excellent cost performance

Conventional system			TELLUS and V-Server	
SCADA (Software)	Display creation and customization	Communication unit (PLC, etc.)	TELLUS and V-Server	V series (Ethernet supported)
Conventional remote control systems require an enormous amount of time and money; expensive equipment and software, exclusive programming by VB/VC, etc. are needed.			Only installation of low-cost application software is needed. The same screen program as for Monitouch V-series in production site can be used without making any additional screen program for remote monitoring.	
High cost!			Low cost!	

Monitoring and control of multiple units by one PC

TELLUS allows you to control and monitor multiple Monitouch panels and PLCs with a single PC, which helps improve the operating efficiency and the cost-effectiveness.

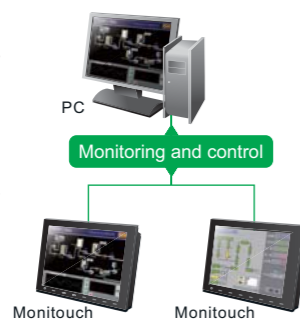

Security functions against operation errors

Security functions such as write-protect are provided to ensure safe and secure system operation.

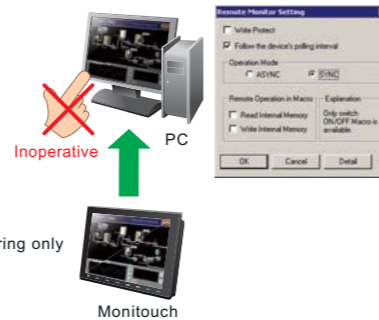

Remote control by means of a simple system

The system is compatible with various systems such as in-house LAN, Internet, WAN, etc.

- You can access the on-site screen via the Internet from a remote location.
- You can monitor overseas plants via WAN.

*It is necessary to modify the setting of firewall and routing for Internet access.

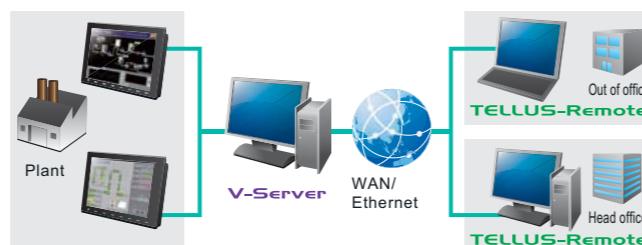

A large screen display allows centralized monitoring of the entire plant.

TELLUS HMI supports full HD resolution. The entire image, which cannot be displayed on one Monitouch display, can be displayed on a large screen display.

<p>Monitouch V815IX Max. resolution: XGA (1,024x768 pixels)</p>	<p>Display HMI mode display area 1,920x1,080 pixels</p>
	<p>Full HD display Full HD 1080</p> <p>Screen Configuration The screen is designed by means of the exclusive configuration software, V-SFT-5. TELLUS Ver.3 allows you to edit in high resolution.</p>

Easy selection of peripheral equipment

It is possible to connect peripheral equipment such as printers and mass storage media that have Windows drivers so that the data can be easily output or saved.



Large expandability combined with various applications

Processing of production data such as summary and analysis can be easily conducted using external software.

<p>Shutdown of OS OS can be shut down on TELLUS without displaying the shutdown menu.</p>	<p>Start-up of application Various applications can be run, including that for viewing a PDF of the troubleshooting manual.</p>	<p>Loading and execution of DLL functions DLL functions that were made individually can be loaded and executed on TELLUS.</p>
--	--	--

Advantages of using V-Server

“I don't have to bother collecting data any more.”



Real-time collection of on-site production data

Production data can be collected in real time without burdening workers. Collected data can be used for reviewing production plans and improving production facilities.



Using collected data to increase production efficiency

Obtaining on-site information in real time makes it possible to draw up appropriate and efficient production plans.

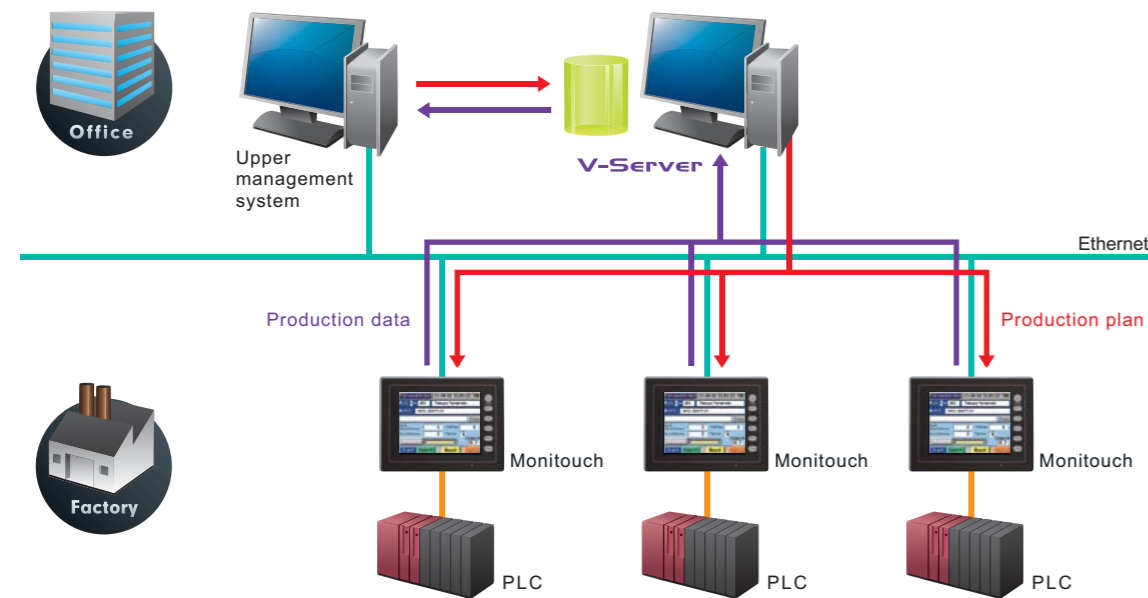

Sending reports upon completion of work

Daily reports are made automatically and accurately to reduce the burden on the production worker and errors.

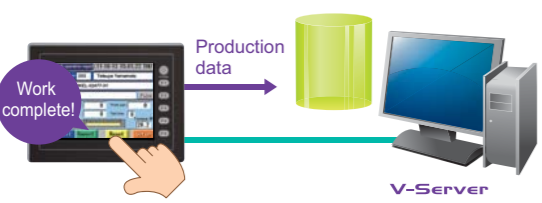

Producing a database of problems

Data on operation stops and errors are analyzed to improve production facilities.



Advantages of using TELLUS-Remote

“We can shorten the downtime.”



Troubleshooting in the office for quick recovery

Prompt response to problems is possible by controlling the production equipment remotely. Production efficiency is improved by shortening downtime, and there is no need to spend the time and money required to send a person to the production site.

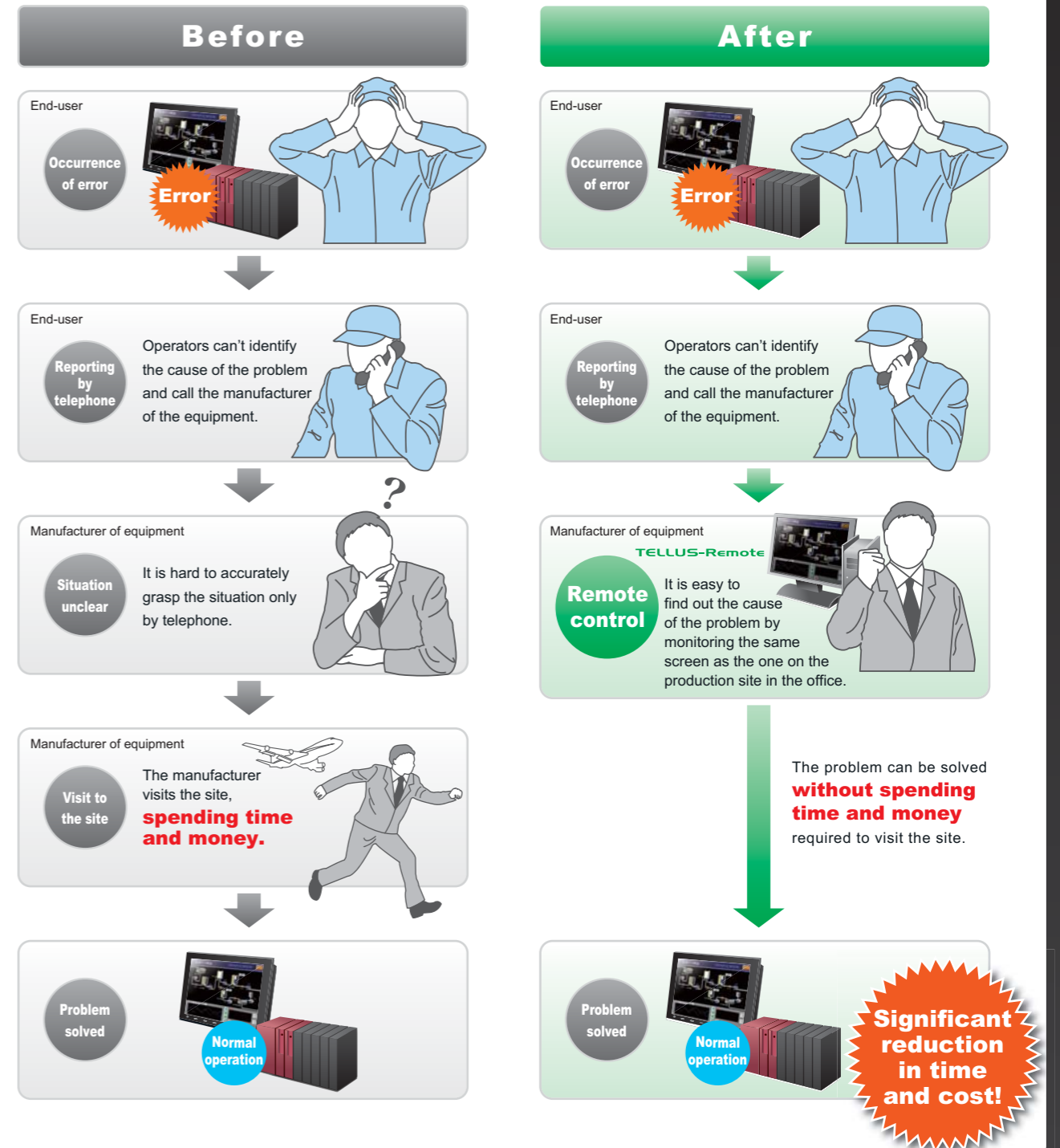

Advantages of using TELLUS-HMI

"I won't miss a problem in production."



An image of the entire production line can be displayed on one large screen.

Equipping a PC with Monitouch functions makes it possible to have a large, full HD display. All operation processes can be displayed on one large screen.

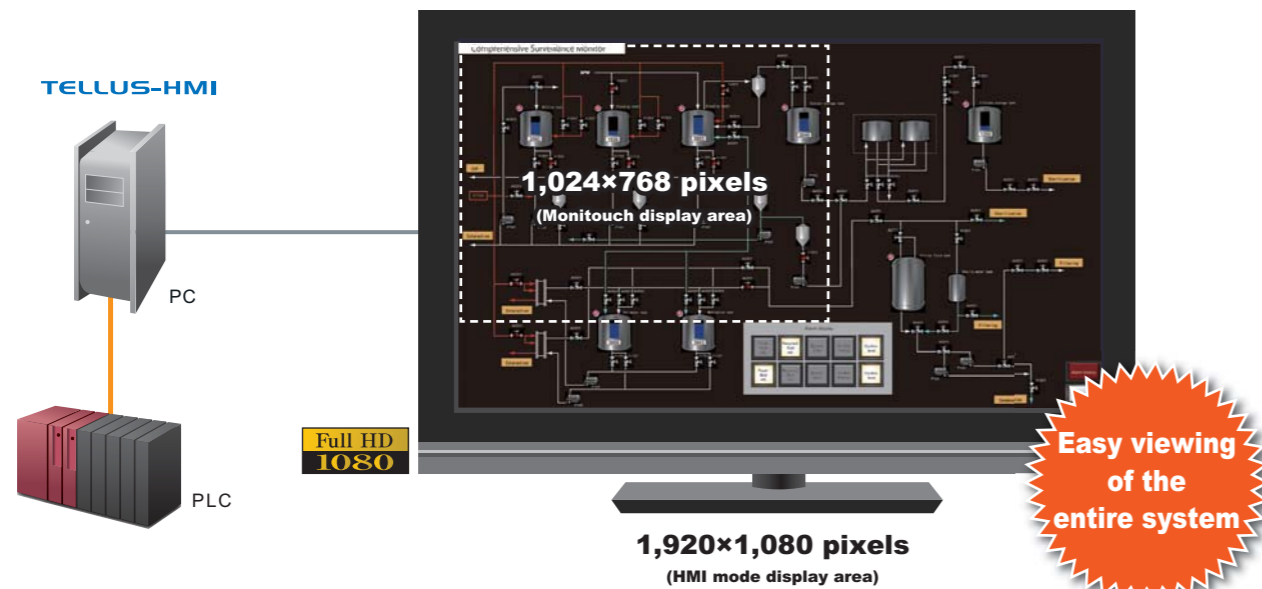

Additional displays only for monitoring is available.

Connection of a large display enables easy viewing of the image data.

Run two TELLUS-HMIs and indicate the data on separate displays.

Display 1
(Primary display)

1

TELLUS-HMI for the primary display



Display properties



Display 2
(Monitoring display)

2



TELLUS-HMI for the monitoring display

RGB cable

Data can be viewed on two displays!



Operation of the primary display does not interfere with the monitoring display.

Compatible Models & Operation Requirements

Compatible Models

V8i series
V8 series with CU-03-3 (Ethernet unit)
V715/V7i series
V7 series with CU-03-3 (Ethernet unit)
V706 and DU-01
V612/V610/V608/V606i with CU-03-3 (Ethernet unit)

Recommended Operating Environment

Please ensure the following conditions are in place for the operation of TELLUS and V-Server.

PC	IBM PC/AT compatibles operable with Windows
OS	Windows 98SE / Me / NT Ver.4.0/2000 / XP / Vista 32bit / Vista 64bit / Windows 7 32bit / Windows 7 64bit
CPU	Pentium III 800MHz or more
Memory	TELLUS : 256MB or more V-Server : 128MB or more
Hard disk*	TELLUS : 80MB or more V-Server : 200MB or more
Display	Resolution: 640x480 or more Colors: High Color 16-bit or more

*When installed

Configuration Software

V-SFT-5 : configuration software for Monitouch V series and TELLUS. You can easily create your own screen program as desired.

License Types

One license is required for each computer. There are four types of licenses depending on the function. (Licenses are framed in red as below.)

1 V-Server

The functions of V-Server are carried out by the server PC.

- Readout/Writing of the recipe data for V-series (or TELLUS HMI)
- Alarm monitoring
- Event action
- Screen data transfer (excluding TELLUS-HMI)

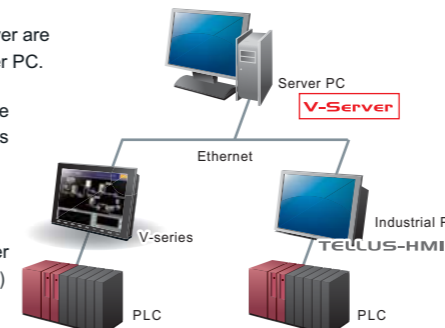

2 TELLUS-Remote

- A client PC equipped with TELLUS accesses V-Server on a server PC via Ethernet and operates the panels of V-series (or TELLUS HMI) remotely.
- HMI communication is also possible.

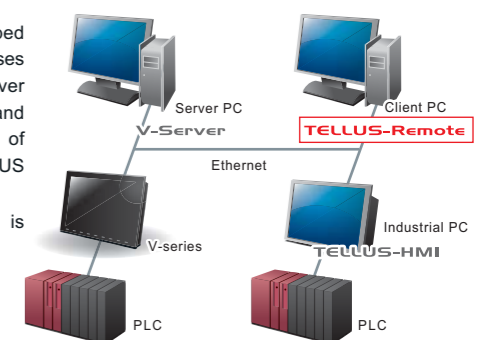

3 TELLUS and V-Server

- A server PC equipped with TELLUS and V-Server can remotely control the panels of V-series (or TELLUS HMI) while conducting V-Server functions.
- HMI communication is also possible.

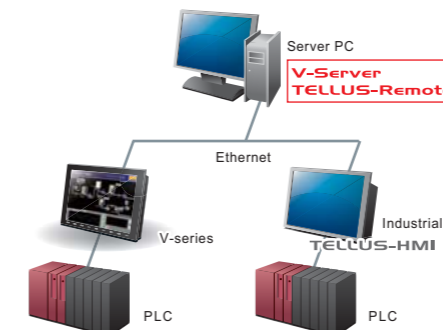

4 TELLUS-HMI

- A PC (or Industrial PC) equipped with TELLUS-HMI and connected with a PLC functions as a V-series panel.

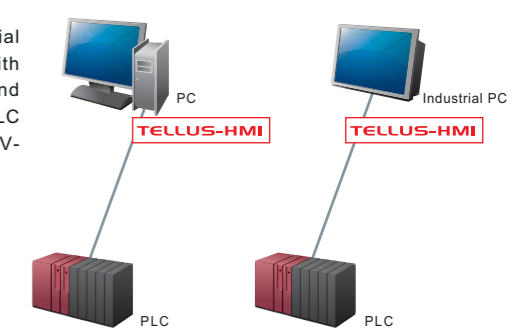

License Validation

There are two types of licenses: Password type and USB license type.

USB license key

TELLUS-HMI USB Key
TELLUS-Remote USB Key
TELLUS and V-Server USB Key



Password validation

TELLUS-HMI
TELLUS-Remote
TELLUS and V-Server
V-Server

License Validation

License validation is restricted to one license per computer. There are four types of licenses, one for each function (See above). Check the type of license for the function(s) you wish to use it for.

Notes: When reinstalling the application software on the same computer, the same password is valid. If you initialize the OS or change the computer on which the application software is installed, the password becomes invalid. In this case, you must go through the license validation procedure again to get a new password.

