

# FCR MICROJET RECORDER-E

DATA SHEET

PHE

This recorder can record up to 6 channels of thermocouples, resistance bulbs and DC voltage/current signals. The adoption of ink jet system makes it possible to record measured data in analog trace and digital color printing (6 colors, max) on a 100mm wide chart paper.

## FEATURES

1. Compact size  
Depth: 175mm, mass; about 1.2kg (continuous type)  
Depth: 197mm, mass; about 1.5kg (6-intermittent type)  
Ideally suited for use with machines and equipments.
2. High-quality recording
  - Continuous traces without pen offset are possible by our unique ink jet system.
  - Scales are printed on a chart paper for each channel, eliminating the need for scale plate.
  - 6 different scale on 6 intermittent recording universal input type is available.
3. Easy setting of input signals  
DC voltage input (5mV span, 50V max.), DC current (4-20mA, 10-50mA), 12 kinds of thermocouples and resistance bulbs (Pt100) are field-settable for each channel.
4. Digital printing  
In addition to analog recording of measured data, periodic data printing, measured value list, scale printing, alarm printing, burnout printing, and parameter list are also available.
5. Easy Operation
  - A cartridge type recording device is used for easy replacement.
  - Allow to draw out the chart paper while recording.

## SPECIFICATIONS

### Input system

- Input points:** 1, 2-continuous recording, 6-intermittent recording
- Input signal:** Thermocouple: B, R, S, K, E, J, T, N, W, L, U, PN  
Resistance bulb: Pt100  
DC voltage: 50mV, 500mV, 5V, 50V range  
DC current: 4 to 20mA DC, 10 to 50mA DC (Shunt resistor (option) need to be connected to the terminal.)

### Input signal setting and change:

Setting and change of input signal between thermocouple, resistance bulb and DC voltage (50mV, 500mV, 5V, 50V range) is possible for each channel by the setting pin in the instrument and keyboard operation.



### Measuring range (Recording range):

Recording range on each channel is settable within the reference range with keyboard operation.

### Measurement cycle:

1, 2-continuous: 0.2s/point  
6-intermittent: 30s/all points

### Burnout:

When thermocouple or resistance bulb input is disconnected, the recording is deflected to 100%.

### Input filter:

Settable within the range of 0-255s by 1s. steps.  
Initial set before delivery is 3 s.

### Reference range

Input signal		°C	°F
Thermocouple	B	400 to 1760	752 to 3200
	R	0 to 1760	32 to 3200
	S	0 to 1760	32 to 3200
	K	-200 to 1370	-328 to 2498
	E	-200 to 800	-328 to 1472
	J	-200 to 1100	-328 to 2012
	T	-200 to 400	-328 to 752
	N	0 to 1300	32 to 2372
	W	0 to 1760	32 to 3200
	L	-200 to 900	-328 to 1652
	U	-200 to 400	-328 to 752
	PN	0 to 1300	32 to 2372
Resistance bulb	Pt 100	-200 to 600	-328 to 1112
DC voltage	±50mV	-50.00 to 50.00mV	
	±500mV	-500.0 to 500.0mV	
	±5V	-5.000 to 5.000V	
	±50V	-50.00 to 50.00V	
	Scaling	Scaling is possible within the range of -32767 to +32767 (decimal point may be put as necessary)	

### Recording system

- Writing system:** Ink jet system, in 6 colors as max.  
**Chart width:** 100mm  
**Chart length:** Z fold 15.08m  
**Service life of ink (depends on operating conditions):**  
About 12 months for 1 continuous line recording at 20mm/h of chart speed.

**Recording color:** 1-continuous: Recording: purple  
 Printing: purple  
 2-continuous: Recording:  
 No. 1 channel, red  
 No. 2 channel, blue  
 Printing: purple  
 6-intermittent recording:  
 No. 1 channel, orange  
 No. 2 channel, green  
 No. 3 channel, purple  
 No. 4 channel, red  
 No. 5 channel, black  
 No. 6 channel, blue  
 Printing: black

**Chart speed:** 10, 20, 24, 30, 50, 120, 200, 300, 400,  
 1000, 1200, 1500 mm/h  
 Can be changed by key operation.  
 Initial set before delivery is 20mm/h  
 (Note) In continuous type, it records  
 data intermittently when the speed ex-  
 ceeds 400mm/h.

**Recording cycle:** **Continuous recording:**  
 Depend on chart speed  
 [Calculation formula]  

$$\text{Recording cycle (sec)} = \frac{400}{\text{chart speed (mm/h)}}$$
 (not faster than 2 seconds.)  
**Intermittent recording:**  
 30 s/all points.

**Industrial unit:** Selectable on each channel in max. 7  
 characters by ASCII code.

**Printing function:**[Printing during analog recording]  
 [Note] Chart speed of continuous type  
 should be slower than 400mm/h  
 and that of intermittent type  
 should be slower than 50mm/h.  
 Channel No. printing: Beside of record-  
 ing line  
 Periodic printing: Channel number, mea-  
 surement value, unit,  
 chart speed and year,  
 month, day, hour, min-  
 ute.  
 [Note] Print period is automatically fixed  
 on chart speed.  
 Scale printing: This print out is effected  
 alternately with periodic  
 printing.  
 [Note] Print interval is automatically  
 fixed on chart speed.  
 Alarm printing: Channel number, kind of  
 alarm and hour, minute.  
 Burnout printing: Channel number and  
 hour, minute.  
 [Printing independent of analog recording]  
 [Note] Printing is performed by key op-  
 eration, while analog recording  
 is interrupted. After completion  
 of the printing, analog recording  
 starts again.

Instantaneous value list: Channel num-  
 ber, measured value,  
 industrial unit, year,  
 month, day, hour,  
 minute.  
 Parameter list (set value list):  
 Input signal, recording  
 range, measuring range,  
 scaling range, unit,  
 alarm, input filter, chart  
 speed, year, month, day,  
 hour, minute, etc.  
 Scale line printing: Optional scale line  
 by user.  
 Test pattern: All characters and color  
 patterns can be printed.  
 [Other printing]  
 Recording start mark  
 Chart speed change mark

**Indicating, key operation system**

**Indication:** LED (7 segments), 6 digits, green  
**Indication character:**  
 7 segments, alphanumeral  
 Character height 10mm, width 5mm  
**Contents of indication:**  
 Channel No.: 1 digit (1 to 6)  
 Measured value:  
 5 digits (including sign for  
 value below 0)  
 Temperature: 1 digit below decimal  
 point  
 Voltage/current:  
 Scaling, -9999 is displayed  
 for -10000 and under.  
 Time: Hour, Minute  
 Status indication:  
 Symbolic code as alarm,  
 burnout or carriage failure.  
 Measurement display cycle:  
 3s for channel selection,  
 1s for data update in the  
 same channel  
**Operation key:** 3 keys and 1 reset key  
 Key lock: soft key lock is available by  
 key operation.

**Power requirement**

**Line supply:** Specify when ordering  
 Rated voltage  
 100 to 120VAC or 200 to 240VAC  
 Usable voltage  
 85 to 132VAC or 180 to 264VAC  
**Frequency:** 50/60Hz  
**Power consumption:**  
 100 to 120VAC or 200 to 240VAC, with-  
 out option, 13VA or less  
 100 to 120VAC or 200 to 240VAC, with  
 alarm, 15VA or less

## Alarm

**Type:** Absolute value alarm, high and low  
**Setting:** Two levels for each channel (high: 2 levels, low: 2 levels, or each level at high/low)  
**Indication:** Alarm level is indicated for each channel at occurrence of alarm.  
**Printing:** Channel No. alarm level and hour, minute.  
**Hysteresis:** Approx. 0.2% of measuring (recording) range  
**Alarm output:** See "Optional specifications"

## Physical data

**Mounting:** Panel (may be inclined up to 30° backwards from the vertical)

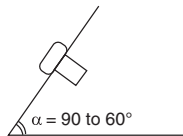

Two or more recorders can be mounted side by side.

**Panel thickness:** 2 to 30mm  
**Material:** Case: mold Front door frame: mold  
**Finish color:** Case: black Front door frame: black  
**Protective structure:**  
 Front door: IEC IP50  
**Case size:** Bezel 144 x 144mm  
 Depth 175mm (Continuous type)  
 195mm (Intermittent type)  
 Cutout 137 x 137mm  
**External terminals:**  
 Screw terminals (M4 screw)  
**Mass:** Approx. 1.2kg (continuous type)  
 Approx. 1.5kg (intermittent type)  
**External terminals:** M4 screw

## Performance and characteristics

**Indication accuracy\*1:**  
 DC voltage, DC current :  
 ±(0.3% of measuring range +1 digit)  
**Thermocouple, Resistance bulb:**  
 Depend on the measuring range for each input signal.  
 Refer to the table below.

input signal	(0.3% of measuring range+1 digit)		(1% of measuring range+1 digit)	
	measuring range		measuring range	
B	1000°C or more	1832°F or more	600°C or more	1112°F or more
R	1000°C or more	1832°F or more	600°C or more	1112°F or more
S	1000°C or more	1832°F or more	600°C or more	1112°F or more
K	300°C or more	572°F or more	200°C or more	392°F or more
E	300°C or more	572°F or more	200°C or more	392°F or more
J	300°C or more	572°F or more	200°C or more	392°F or more
T	300°C or more	572°F or more	200°C or more	392°F or more
N	300°C or more	572°F or more	200°C or more	392°F or more
W	500°C or more	932°F or more	400°C or more	752°F or more
L	300°C or more	572°F or more	200°C or more	392°F or more
U	300°C or more	572°F or more	200°C or more	392°F or more
PN	300°C or more	572°F or more	200°C or more	392°F or more
Pt100	150°C or more	302°F or more	50°C or more	122°F or more

[Note] 1. For thermocouple input, in case of measuring range includes -200°C to -100°C (-328°F to -148°F), indication accuracy should be added +0.5%.  
 2. The indication accuracy of thermocouple does not include reference junction compensating error.

**Resolution\*1:** Thermocouple input : 0.1°C 0.1°F  
 Resistance bulb : 0.1°C 0.1°F  
 DC voltage : ±50mV : 10μV  
 : ±500mV : 100μV  
 : ±5V : 1mV  
 : ±50V : 10mV  
 DC current : converted value to DC voltage is guaranteed

**Recording accuracy \*1:**  
 Indication accuracy ±(0.2% of measuring range)

**Recording resolution:**  
 0.1mm

**Chart speed accuracy:**  
 ±0.1% (in case continuous feed of more than 1m. Expansion and contraction of paper is not included)

**Reference junction compensation accuracy:**  
 K, E, J, T, N, L, U, PN : ±0.5°C  
 B, R, S, W : ±1°C

**90% response time:**  
 Less than 2s (continuous type only)

**Maximum input voltage:**  
 Thermocouple, resistance bulb and DC voltage (50mV, 500mV range):  
 ±10V DC or less  
 DC 5V/50V range: ±100V DC or less

**Input resistance:** Thermocouple, 50mV voltage range  
 > 10MΩ  
 5V/50V range: > 1MΩ  
 500mV range: > 100kΩ

**Isolation:** 100MΩ (between each terminal and earth at 500V DC)  
 Channel to channel:  
 500V AC, 1min  
 Power terminal to ground: 2000V AC, 1min  
 Input terminal to ground: 500V AC, 1min  
 Power terminal to input terminal: 1000V AC, 1min  
 Alarm to alarm: 750V AC, 1min  
 (leak current: 5mA or less)

**Common mode noise rejection:**  
 120dB (50/60Hz)

**Series mode noise rejection:**  
 30dB (50/60Hz)

**Clock accuracy:** ±50ppm (2 minutes per month)

**Memory protection:** Non-volatile memory for parameters.  
 Lithium battery for clock.

[Note] \*1 Measurement condition:  
 23±2°C, 65±10% RH, power voltage 100 to 120V, 200 to 240V, frequency 50/60Hz within 1%, warm-up time 30min or more, vertical mounting, and free from the effects of vibration, noise, etc.

### Operating environment

Temperature limits: 0 to 50°C

Humidity limits: 20 to 80%RH  
(temperature × humidity < 3200)

Mounting position:

Front inclination 0°, rear inclination 30°,  
left/right inclination 0°

Signal source resistance:

Thermocouple input: 1kΩ or less

Resistance bulb input: Less than 10Ω  
(line resistance of each wire of 3-wires  
system should be balanced)

Voltage input: Less than 0.1% of input  
resistance

Vibration: 10 to 60Hz, 0.2m/s<sup>2</sup> or less

Shock: None

### Optional specifications

Alarm output (DO):

2, 4 or 6 points N.O contact relay (refer  
to code symbols)

Contact capacity 250V AC/3A.

30V DC/3A (resistance load)

Alarm output unit is required.

External control input (DI):

1 point, no-voltage contact input is  
used for selection of chart speed in 2  
steps.

Normally, operation is effected at main  
chart speed.

Sub-speed is selected with contact  
ON, and main speed with contact OFF.

Main/sub speed is set by key operation.  
When sub-speed is set to 0mm/h, re-  
cording start/stop can be selected.

Alarm output /external control input unit  
is required.

### Other functions

Printing/recording adjustment:

Make adjustment when characters  
bend and/or disturbance of record (round  
trip difference) occur.

Adjustment of zero/span of analog trend record position:

The position of ink cartridge is adjusted  
for correct recording on 0% point and  
100% point on chart paper.

This adjustment should be made after  
replacement of ink cartridge or chart  
paper.

Measured value shift:

Indication or recording value is shifted  
by adding or subtracting calculation of  
measured value.

Sub chart speed: This is for selecting chart speed with  
external control input. It is selected  
from the following.

0, 10, 20, 30, 50, 120, 200, 300, 400,  
1000, 1200, 1500mm/h

Initial set before delivery: 20mm/h

0mm/h means stop recording.

Channel skip: This is used to stop the operation of  
unused channel. Skipped channel stops  
all operations including display and  
alarm.

Setting recording status at power ON:

Recording can be started again or  
disabled when power is ON or when  
power is recovered from failure.

Real time clock: Setting year, month, day, hour, minute

## CODE SYMBOLS

1 2 3 4 5 6 7 8 9 10 11 12 13													Description
P	H	E	0	0	2	-	V	V	E	V			Recording points <4th digit code>
			1										1 continuous recording
			2										2 continuous recording
			9										6 intermittent recording
													Power supply • Temperature Unit <7th digit code>
			1										100 to 120VAC 50/60Hz °C
			2										200 to 240VAC 50/60Hz °C
			3										100 to 120VAC 50/60Hz °F
			4										200 to 240VAC 50/60Hz °F
													Alarm output/external control input (1 point) <11th digit code>
			0										Without
			1										2 points alarm output (1 continuous only)
			2										4 points alarm output (2 continuous only)
			3										6 points alarm output (6-intermittent only)
			A										2 points alarm output/External control (1 continuous only)
			B										4 points alarm output/External control (2 continuous only)
			C										6 points alarm output/External control (6 intermittent only)

Input : Universal (Programmable)  
Range: Field settable (Programmable)

- Note) 1. Initial set before delivery is ;  
• Thermocouple K type 0 to 1200°C  
2. Shunt resistor (10Ω ±0.1%) should be ordered separately for current input.  
Shunt Resistor : Ordering code PHZT1101  
3. When changing the kinds of input signal, some adjustments may become necessary.

## SCOPE OF DELIVERY

Recorder, panel mounting bracket, accessories  
(ink cartridge 1 pc, chart paper 1 roll, input signal setting pin for replacement 1pc, ink absorption cloth 1 sheet). instruction manual (1 copy)

Note: Ink cartridge is not mounted on the recorder at the time of delivery.

### Spare parts

Item	Part No.	Unit of quantity for sale
Ink cartridge	PHZH2002 (1, 2-continuous)	1 pc
	PHZH1002 (6-intermittent)	1 pc
Chart paper (0 to 50, 50 uniform division)	PEX00DL1 - 5000B	1 box (6 charts)

### Other (optional items)

Item	Type	Specification
Shunt resistor	PHZT1101	For 10Ω±0.1%

# OUTLINE DIAGRAM (Unit:mm)

## 1-continuous type

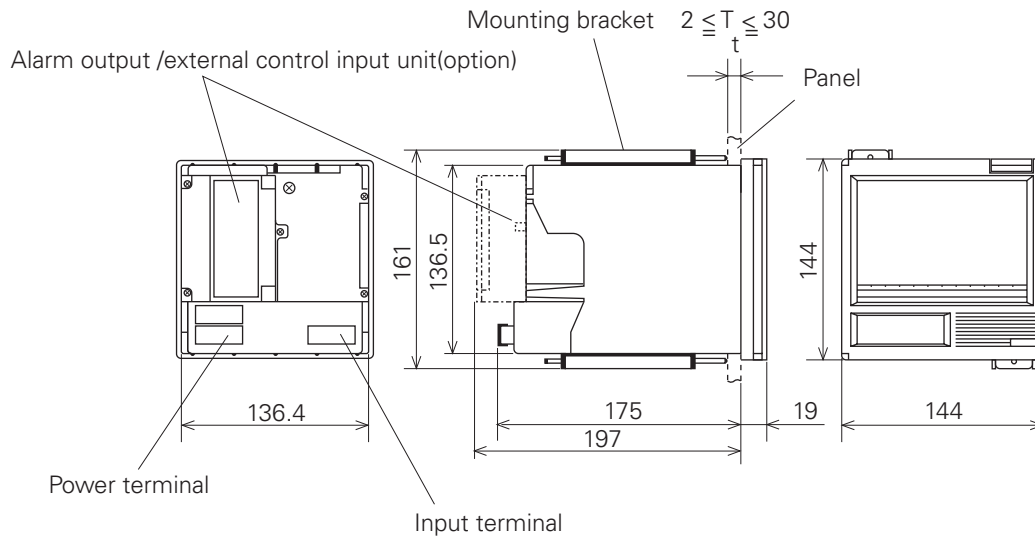

### Panel cutout

When mounting one unit

When mounting multiple n unit

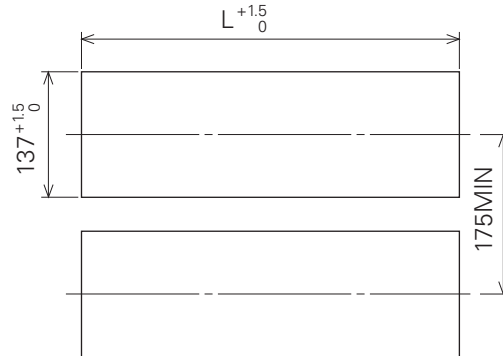
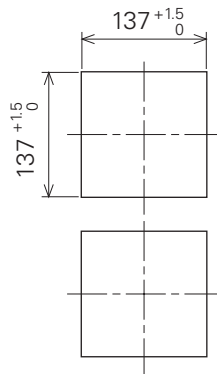

No. of units	$L^{+1.5}_0$ (mm)
2	282
3	426
4	570
5	714
6	858
7	1002
8	1146
9	1290
10	1434
n	(144 x n) - 6

### Connection diagram

Alarm output / external control input unit

①①	○	○	②①	Alarm output 1
①②	○	○	②②	Alarm output 2
①③			②③	Not used
①④			②④	Not used
①⑤			②⑤	Not used
①⑥			②⑥	Not used
①⑦	○	○	②⑦	External control input
①⑧			②⑧	Not used
①⑨			②⑨	Not used

### Power terminal

100 to 120VAC or  
200 to 240VAC  
50/60HZ

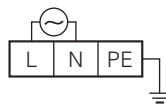

### Input terminal

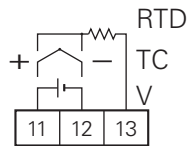

# OUTLINE DIAGRAM (Unit:mm)

## 2-continuous type

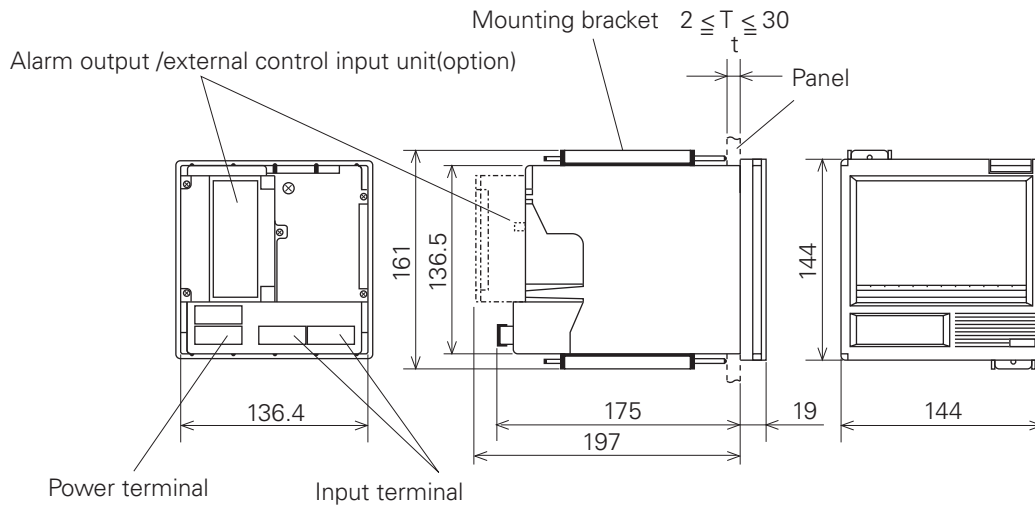

### Panel cutout

When mounting one unit

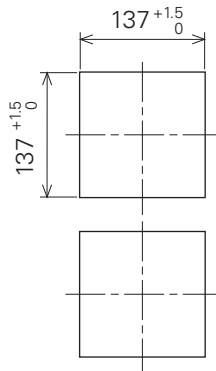

When mounting multiple n unit

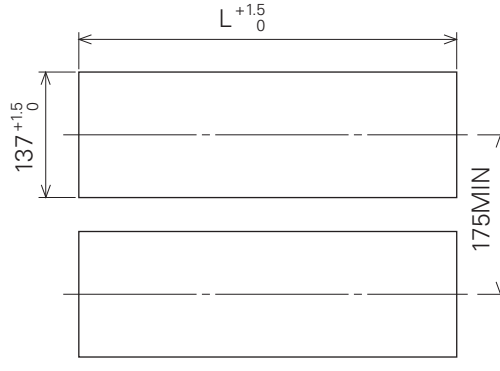

No. of units	$L^{+1.5}_0$ (mm)
2	282
3	426
4	570
5	714
6	858
7	1002
8	1146
9	1290
10	1434
n	$(144 \times n) - 6$

### Connection diagram

Alarm output /external control input unit

(11) — (21)	Alarm 1
(12) — (22)	Alarm 2
(13) — (23)	Alarm 3
(14) — (24)	Alarm 4
(15) — (25)	Not used
(16) — (26)	Not used
(17) — (27)	External control input
(18) — (28)	Not used
(19) — (29)	Not used

### Power terminal

100 to 120VAC or  
200 to 240VAC  
50/60HZ

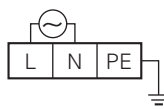

### Input terminal

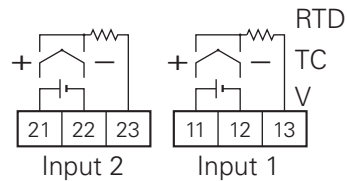

# OUTLINE DIAGRAM (Unit:mm)

## 6-intermittent type

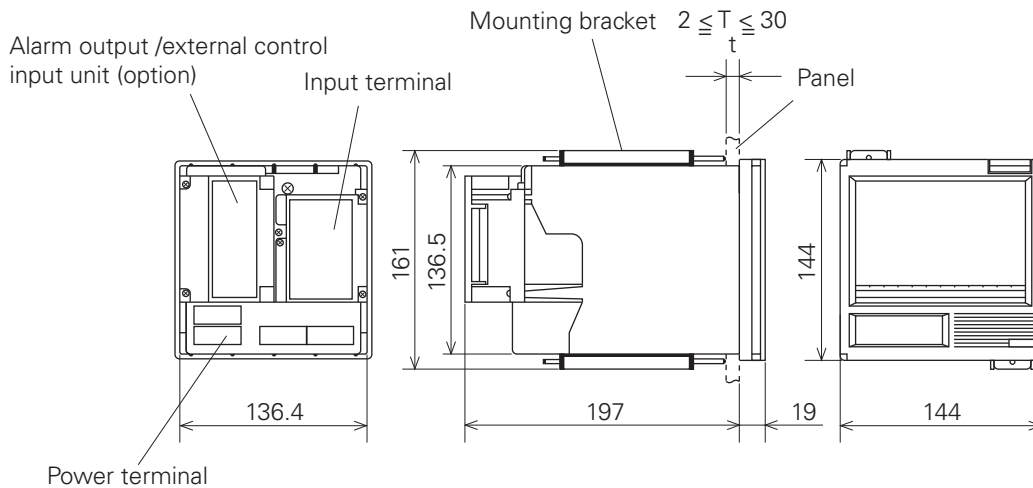

Panel cutout  
When mounting one unit

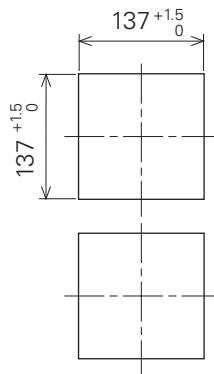

When mounting multiple n unit

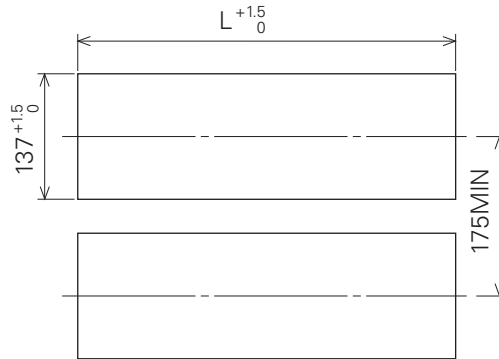

No. of units	$L^{+1.5}_0$ (mm)
2	282
3	426
4	570
5	714
6	858
7	1002
8	1146
9	1290
10	1434
n	(144 x n) - 6

### Connection diagram

Alarm output /external control input unit

⑪	○	○	⑫	○	⑬	○	⑭	○	⑮	○	⑯	○	⑰	○	⑱	○	⑲	○	⑳	○	㉑	○	㉒	○	㉓	○	㉔	○	㉕	○	㉖	○	㉗	○	㉘	○	㉙	○	㉚	○	㉛	○	㉜	○	㉝	○	㉞	○	㉟	○	㊱	○	㊲	○	㊳	○	㊴	○	㊵	○	㊶	○	㊷	○	㊸	○	㊹	○	㊺	○	㊻	○	㊼	○	㊽	○	㊾	○	㊿	○	1	○	2	○	3	○	4	○	5	○	6	○	External control input	○	Not used	○	Not used	○
---	---	---	---	---	---	---	---	---	---	---	---	---	---	---	---	---	---	---	---	---	---	---	---	---	---	---	---	---	---	---	---	---	---	---	---	---	---	---	---	---	---	---	---	---	---	---	---	---	---	---	---	---	---	---	---	---	---	---	---	---	---	---	---	---	---	---	---	---	---	---	---	---	---	---	---	---	---	---	---	---	---	---	---	---	---	---	---	---	---	---	---	---	------------------------	---	----------	---	----------	---

### Power terminal

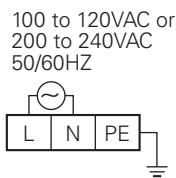

### Input terminal

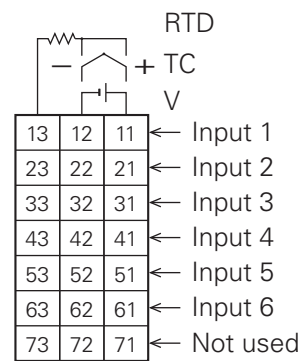

CE mark

\*The products conform to the requirements of the Electro magnetic compatibility Directive and Low voltage Directive.

⚠ Caution on Safety

\*Before using this product, be sure to read its instruction manual in advance.

# Fuji Electric

Your distributor:

**Coulton Instrumentation Ltd**

17 Somerford Business Park, Christchurch, BH23 3RU, UK

Tel: +44 1202 480 303

E-mail: sales@coulton.com

Web: www.coulton.com