

# DIFFERENTIAL PRESSURE (FLOW) TRANSMITTER

## DATA SHEET

**FKC...5**

The FCX-All differential pressure (flow) transmitter accurately measures differential pressure, liquid level, gauge pressure or flow rate and transmits a proportional 4 to 20mA signal. The transmitter utilizes a unique micromachined capacitance silicon sensor with state-of-the-art microprocessor technology to provide exceptional performance and functionality.

## FEATURES

- High accuracy up to  $\pm 0.04\%$**   
0.065% accuracy as standard, 0.04% accuracy as option.  
Fuji's micro-capacitance silicon sensor assures this accuracy for all elevated or suppressed calibration ranges without additional adjustment.
- Minimum environmental influence**  
The "Advanced Floating Cell" design which protects the pressure sensor against changes in temperature, static pressure, and overpressure substantially reduces total measurement error in actual field applications.
- Fuji/HART® bilingual communications protocol**  
FCX-All series transmitter offers bilingual communications to speak both Fuji proprietary protocol and HART®. Any HART® compatible devices can communicate with FCX-All
- Application flexibility**  
Various options that render the FCX-All suitable for almost any process applications include.
  - Full range of hazardous area approvals
  - Built-in RFI filter and lightning arrester
  - 5-digit LCD meter with engineering unit
  - Stainless steel electronics housing
  - Wide selection of materials
- Programmable output Linearization Function**  
In addition to Linear and Square Root, output signal can be freely programmable.  
(Up to 14 compensated points at approximation.)
- Burnout current flexibility (Under Scale: 3.2 to 4.0mA, Over Scale: 20.0 to 22.5mA)**  
Burnout signal level is adjustable using Model FXW or Hand Held Communicator (HHC) to comply with NAMUR NE43.
- Dry calibration without reference pressure**  
Thanks to the best combination of unique construction of mechanical parts (Sensor unit) and high performance electronics circuit (Electronics unit), reliability of dry calibration without reference pressure is at equal level as wet calibration.



## SPECIFICATIONS

### Functional specifications

#### Type :

**FKC** : Smart, 4 to 20mA DC + Fuji / Hart® digital signal

#### Service :

Liquid, gas, or vapour

#### Static pressure, span, and range limit :

Type	Static pressure MPa {bar}	Span limit kPa {m bar}		Range limit kPa {m bar}
		Min.	Max.	
FKC□11	-0.1 to +3.2 {-1 to +32}	0.1 {1}	1 {10}	$\pm 1$ { $\pm 10$ }
FKC□22	-0.1 to +10 {-1 to +100}	0.1 {1}	6 {60}	$\pm 6$ { $\pm 60$ }
FKC□33	-0.1 to +16 {-1 to +160}	0.32 {3.2}	32 {320}	$\pm 32$ { $\pm 320$ }
FKC□35	-0.1 to +16 {-1 to +160}	1.3 {13}	130 {1300}	$\pm 130$ { $\pm 1300$ }
FKC□36	-0.1 to + 16 {-1 to +160}	5 {50}	500 {5000}	$\pm 500$ { $\pm 5000$ }
FKC□38	-0.1 to +16 {-1 to +160}	30 {300}	3000 {30000}	$\pm 3000$ { $\pm 30000$ }
FKC□43	-0.1 to +42 {-1 to +420}	0.32 {3.2}	32 {320}	$\pm 32$ { $\pm 320$ }
FKC□45	-0.1 to +42 {-1 to +420}	1.3 {13}	130 {1300}	$\pm 130$ { $\pm 1300$ }
FKC□46	-0.1 to +42 {-1 to +420}	5 {50}	500 {5000}	$\pm 500$ { $\pm 5000$ }
FKC□48	-0.1 to +30 {-1 to +300}	30 {300}	3000 {30000}	$\pm 3000$ { $\pm 30000$ }
FKC□49*	-0.1 to +30 {-1 to +300}	500 {5000}	20000 {200000}	+20000,-10000 {+200000,-100000}

Remark : To minimize environmental influence, span should be greater than 1/40 of the max. span in most applications.

Important\* : Max possible overload pressure on LP side must be  $\leq 100$ bar

Lower limit of static pressure (vacuum limit) ;

Silicone fill sensor: See Fig. 1

Fluorinated fill sensor:

66kPa abs (500mmHg abs) at temperature below 60°C

**Over range limit :**

To maximum static pressure limit

**Output signal :**

4 to 20mA DC (linear or square root) with digital signal superimposed on the 4 to 20mA signal

**Power supply :**

Transmitter operates on 10.5V to 45V DC at transmitter terminals.

10.5V to 32V DC for the units with optional arrester.

**Load limitations :** see figure below

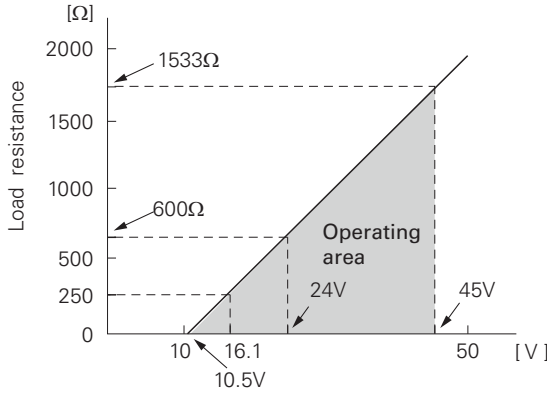

Note: For communication with HHC<sup>(1)</sup> (Model: FXW), min. of 250Ω required.

**Hazardous locations :**

Authority (Digit 10 = )	Intrinsic safety																					
ATEX (K)	Ex II 1 G Ex ia IIC T5 (-40°C ≤ Ta ≤ +50 °C) Ex ia IIC T4 (-40°C ≤ Ta ≤ +70 °C) IP66/67 Entity Parameters: Ui ≤ 28 Vdc, Ii ≤ 94.3 mA, Pi ≤ 0.66 W Ci = 36 nF/26 nF for models with/without Arrester Li = 0.7 mH/0.6 mH for models with/without Analog Indicator																					
Factory Mutual (H)	Class I II III Div.1 Groups A, B, C, D, E, F, G T4 Entity Type 4X <table border="1"> <thead> <tr> <th colspan="2">Model code</th> <th>Tamb</th> </tr> <tr> <th>9th digit</th> <th>13th digit</th> <th></th> </tr> </thead> <tbody> <tr> <td>A,B,C,D,J</td> <td>Y,G,N</td> <td>-40°C to +85°C</td> </tr> <tr> <td>L,P,M,1,2,3</td> <td>Y,G,N</td> <td>-20°C to +80°C</td> </tr> <tr> <td>Q,S,N,4,5,6</td> <td>Y,G,N</td> <td>-20°C to +60°C</td> </tr> <tr> <td>E,F,G,H,K</td> <td>Y,G,N</td> <td>-40°C to +60°C</td> </tr> <tr> <td>-</td> <td>W,A,D</td> <td>-10°C to +60°C</td> </tr> </tbody> </table> Entity Parameters: Vmax=42.4V, Imax=113mA, Pi=1W, Ci=35.98nF, Li=0.694mH	Model code		Tamb	9th digit	13th digit		A,B,C,D,J	Y,G,N	-40°C to +85°C	L,P,M,1,2,3	Y,G,N	-20°C to +80°C	Q,S,N,4,5,6	Y,G,N	-20°C to +60°C	E,F,G,H,K	Y,G,N	-40°C to +60°C	-	W,A,D	-10°C to +60°C
Model code		Tamb																				
9th digit	13th digit																					
A,B,C,D,J	Y,G,N	-40°C to +85°C																				
L,P,M,1,2,3	Y,G,N	-20°C to +80°C																				
Q,S,N,4,5,6	Y,G,N	-20°C to +60°C																				
E,F,G,H,K	Y,G,N	-40°C to +60°C																				
-	W,A,D	-10°C to +60°C																				
CSA (J)	Ex ia Class I, Groups A, B, C and D; Class II, Groups E,F and G; Class III Per drawing TC 522873 Temp. code T5 for Tamb max = +50°C Temp. code T4 for Tamb max = +70°C Entity Parameters: Vmax = 28 Vdc, Imax = 94.3 mA, Pmax = 0.66 W Ci = 36 nF/25 nF for models with/without Arrester Li = 0.7 mH/0.6 mH for models with/without Analog Indicator																					
IECEX (T)	Ex ia IIC T5 (-40°C ≤ Ta ≤ +50 °C) Ex ia IIC T4 (-40°C ≤ Ta ≤ +70 °C) IP66/67 Entity Parameters: Ui ≤ 28 Vdc, Ii ≤ 94.3 mA, Pi ≤ 0.66 W Ci = 36 nF/26 nF for models with/without Arrester Li = 0.7 mH/0.6 mH for models with/without Analog Indicator																					

Authority (Digit 10 = )	Type n Nonincendive																					
ATEX (P)	Ex II 3 G Ex nA II T5 (-40°C ≤ Ta ≤ +70 °C) IP66/67 Electrical ratings Model Without arrester: Ui ≤ 45 Vdc, 4-20 mA loop powered, Pi ≤ 1.0125 W Model With arrester: Ui ≤ 32 Vdc, 4-20 mA loop powered, Pi ≤ 1.0125 W Optional Analog indicator is not available for type "n"																					
Factory Mutual (H)	Class I II III Div.2 Groups A, B, C, D, F, G T4 Entity Type 4X <table border="1"> <thead> <tr> <th colspan="2">Model code</th> <th>Tamb</th> </tr> <tr> <th>9th digit</th> <th>13th digit</th> <th></th> </tr> </thead> <tbody> <tr> <td>A,B,C,D,J</td> <td>Y,G,N</td> <td>-40°C to +85°C</td> </tr> <tr> <td>L,P,M,1,2,3</td> <td>Y,G,N</td> <td>-20°C to +80°C</td> </tr> <tr> <td>Q,S,N,4,5,6</td> <td>Y,G,N</td> <td>-20°C to +60°C</td> </tr> <tr> <td>E,F,G,H,K</td> <td>Y,G,N</td> <td>-40°C to +60°C</td> </tr> <tr> <td>-</td> <td>W,A,D</td> <td>-10°C to +60°C</td> </tr> </tbody> </table>	Model code		Tamb	9th digit	13th digit		A,B,C,D,J	Y,G,N	-40°C to +85°C	L,P,M,1,2,3	Y,G,N	-20°C to +80°C	Q,S,N,4,5,6	Y,G,N	-20°C to +60°C	E,F,G,H,K	Y,G,N	-40°C to +60°C	-	W,A,D	-10°C to +60°C
Model code		Tamb																				
9th digit	13th digit																					
A,B,C,D,J	Y,G,N	-40°C to +85°C																				
L,P,M,1,2,3	Y,G,N	-20°C to +80°C																				
Q,S,N,4,5,6	Y,G,N	-20°C to +60°C																				
E,F,G,H,K	Y,G,N	-40°C to +60°C																				
-	W,A,D	-10°C to +60°C																				
CSA (J)	Class I Div.2 Groups A, B, C, D Class II Div.2 Groups E, F, G Class III Div.2 Temp Code T5 Tamb max = +50°C Temp Code T4 Tamb max = +70°C Entity Parameters: Vmax = 28 Vdc, Imax = 94.3 mA, Pmax = 0.66 W Ci = 36 nF/25 nF for models with/without Arrester Li = 0.7 mH/0.6 mH for models with/without Analog Indicator																					
IECEX (Q)	Ex nA II T5 (-40°C ≤ Ta ≤ +70 °C) IP66/67 Electrical ratings Model Without arrester: Ui ≤ 45 Vdc, 4-20 mA loop powered, Pi ≤ 1.0125 W Model With arrester: Ui ≤ 32 Vdc, 4-20 mA loop powered, Pi ≤ 1.0125 W Optional Analog indicator is not available for type "n"																					
Authority	Flameproof																					
ATEX (X)	Ex II 2 GD Ex d IIC T6 (-40°C ≤ Ta ≤ +65 °C) Ex d IIC T5 (-40°C ≤ Ta ≤ +85 °C) Ex tD A21 IP66/67 T 85°C Ex tD A21 IP66/67 T 100°C Electrical ratings Model Without arrester: Ui ≤ 45 Vdc, 4-20 mA loop powered, Pi ≤ 1.0125 W Model With arrester: Ui ≤ 32 Vdc, 4-20 mA loop powered, Pi ≤ 1.0125 W																					
Factory Mutual (D)	Class I Div.1 Groups B, C, D T6 Type 4X Class II III Div.1 Groups E, F, G T6 Type 4X Tamb max = +60°C																					
CSA (E)	Class I, Groups C and D; Class II, Groups E,F and G ; Class III Maximum ambient temperature 85°C Maximum working pressure 50 Mpa Electrical ratings Model Without arrester: Ui ≤ 45 Vdc, 4-20 mA Model With arrester: Ui ≤ 32 Vdc, 4-20 mA Note: "Seal not required"																					
IECEX (R)	Ex d IIC T6 (-40°C ≤ Ta ≤ +65 °C) Ex d IIC T5 (-40°C ≤ Ta ≤ +85 °C) DIP A21 IP66/67 T 85°C DIP A21 IP66/67 T 100°C Electrical ratings Model Without arrester: Ui ≤ 45 Vdc, 4-20 mA loop powered, Pi ≤ 1.0125 W Model With arrester: Ui ≤ 32 Vdc, 4-20 mA loop powered, Pi ≤ 1.0125 W																					

**Zero/span adjustment :**

Zero and span are adjustable from the HHC<sup>(1)</sup>. Zero and span are also adjustable externally from the adjustment screw.

**Damping :**

Adjustable from HHC<sup>(1)</sup> or local adjustment unit with LCD display.

The time constant is adjustable between 0 to 32 seconds.

**Zero elevation / suppression :**

-100% to +100% of URL

**Normal / reverse action :**

Selectable from HHC<sup>(1)</sup>

**Indication :**

Analog indicator or 5-digit LCD meter, as specified.

**Burnout direction :** Selectable from HHC<sup>(1)</sup>

If self-diagnostic detect transmitter failure, the analog signal will be driven to either "Output Hold", "Output Overscale" or "Output Underscale" modes.

"Output Hold" :

Output signal is hold as the value just before failure happens.

"Output Overscale" :

Adjustable within the range 20.0mA to 22.5mA from HHC<sup>(1)</sup>

"Output Underscale" :

Adjustable within the range 3.2mA to 4.0mA from HHC<sup>(1)</sup>  
Output limits conforming to NAMUR NE43 by order.

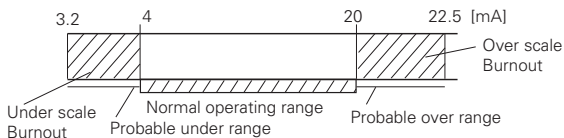

**Loop-check output :**

Transmitter can be configured to provide constant signal 3.2mA through 22.5mA by HHC<sup>(1)</sup>.

**Temperature limit :**

- Ambient : -40 to +85°C
- (-20 to +80°C for LCD indicator)
- (-40 to +60°C for arrester option)
- (-10 to +60°C for fluorinated oil filled transmitters)

For explosionproof units (flameproof or intrinsic safety), ambient temperature must be within the limits specified in each standard.

- Process : -40 to +120°C for silicone fill sensor
- 20 to +80°C for fluorinated oil fill sensor

Storage : -40 to +90°C

**Humidity limit :**

0 to 100% RH

**Communication :**

With HHC<sup>(1)</sup> (Model FXW, consult datasheet N° EDS8-47), following items can be remotely displayed or configured.

Note: HHC's version must be higher than 7.0 (or FXW □□□□1-□4), for FCX-AII. for supporting these items : "Saturate current", "Write protect", and "History".

Items	Fuji Protocol with FXW		Hart® Protocol	
	Display	Set	Display	Set
Tag No.	✓	✓	✓	✓
Model No.	✓	✓	—	—
Serial No. & Software Version	✓	—	✓	—
Engineering unit	✓	✓	✓	✓
Range limit	✓	—	✓	—
Measuring range	✓	✓	✓	✓
Damping	✓	✓	✓	✓
Output mode	Linear	✓	✓	✓
	Square root	✓	✓	✓
Burnout direction	✓	✓	✓	✓
Calibration	✓	✓	✓	✓

Output adjust	—	✓	—	✓
Data	✓	—	✓	—
Self diagnoses	✓	—	✓	—
Printer (In case of FXW with printer option)	✓	—	—	—
External switch lock	✓	✓	✓	✓
Transmitter display	✓	✓	✓	✓
Linearize*	✓	✓	—	—
Rerange	✓	✓	✓	✓
Saturate current	✓	✓	✓	✓
Write protect	✓	✓	✓	✓
History				
– Calibration history	✓	✓	✓	✓
– Ambient temperature history	✓	—	✓	—

(Note) (1) HHC: Hand Held Communicator

**\*Local configurator with LCD display (option) :**

Local configurator with 3 push button and LCD display can support all items (Fuji Protocol list) except "Linearize" function.

**Programmable output linearization function :**

Output signal can be characterized with "14 points linear approximation function" from HHC<sup>(1)</sup>.

**Performance specifications for linear output**

Reference conditions, silicone oil fill, 316SS isolating diaphragms, 4 to 20mA analog output in linear mode.

**Accuracy rating :**

(including linearity, hysteresis, and repeatability)

**Max span : 32kPa models and above**

- For spans greater than 1/10 of URL: ±0.065% of span or ±0.04% of span (optional)
- For spans below 1/10 of URL:

$$\pm \left( 0.015 + 0.05 \frac{0.1 \times \text{URL}}{\text{Span}} \right) \% \text{ of span}$$

**Max span 20MPa models :**

- For spans ≥ 5MPa : ±0.1% of span
- For spans < 5MPa :

$$\pm \left( 0.05 + 0.05 \frac{5\text{MPa}}{\text{Span}} \right) \% \text{ of span}$$

**Max span 1kPa, 6kPa models :**

- For spans greater than 1/10 of URL: ±0.1% of span
- For spans below 1/10 of URL :

$$\pm \left( 0.05 + 0.05 \frac{0.1 \times \text{URL}}{\text{Span}} \right) \% \text{ of span}$$

**Stability :**

±0.1% of upper range limit (URL) for 10 years for 6th digit code 3, 5, 6, 8 and 9.

**Temperature effect :**

Effects per 28°C change between the limits of -40°C and +85°C

Range code (6th digit in code symbols)	Zero shift	Total effect
"1"/1kPa {10mbar} "2"/6kPa {60mbar}	$\pm \left( 0.125 + 0.1 \frac{\text{URL}}{\text{Span}} \right) \%$	$\pm \left( 0.15 + 0.1 \frac{\text{URL}}{\text{Span}} \right) \%$
"3"/32kPa {320mbar} "5"/130kPa {1300mbar} "6"/500kPa {5000mbar} "8"/3000 kPa {30000mbar} "9"/20000kPa {200000mbar}	$\pm \left( 0.075 + 0.0125 \frac{\text{URL}}{\text{Span}} \right) \%$	$\pm \left( 0.095 + 0.0125 \frac{\text{URL}}{\text{Span}} \right) \%$

Double the effects for material code (7th digit in codes symbols) "H", "M", "T"

**Static pressure effect :**

Static pressure code (5th digit in Code symbols)	Zero shift (% of URL)
"1" / 1kPa {10mbar} sensor "2" / 6kPa {60mbar} sensor	±0.2% / 2MPa {20bar} ±0.2% / 3.2MPa {32bar}
"3", "4" "4"	±0.035% / 6.9MPa {69bar} ±0.2% / 6.9MPa {69bar} FKC□49

Double the effects for material code (7th digit in codes symbols) "H", "M", "T"

**Overrange effect :**

Static pressure code (5th digit in Code symbols)	Zero shift (% of URL)
"1" / 1kPa {10mbar} sensor "2" / 6kPa {60mbar} sensor	±0.3% / 2MPa {20bar} ±0.1% / 3.2MPa {32bar}
"3" "3" "4" "4"	±0.1% / 16MPa {160bar} FKC□35,36,38 ±0.15% / 16MPa {160bar} FKC□33 ±0.25% / 42MPa {420 bar} FKC□33,35,36,38 ±0.2% / 10MPa {100 bar} FKC□49

Double the effects for material code (7th digit in codes symbols) "H", "M", "T"

**Supply voltage effect :**

Less than 0.005% of calibrated span per 1V

**Update rate :** 60 msec

**Response time :** (at 63,2% of output signal)

Range code (6th digit in code symbols)	Time constant (at 23°C)	Dead time
"1"	0.33 s	0.12 s
"2"	0.3 s	
"3"	0.12 s	
"5" through "8"	0.08 s	

Response time = time constant + dead time

**Mounting position effect :**

Zero shift, less than 0.12kPa {1.2m bar} for a 10° tilt in any plane.

No effect on span.

This error can be corrected by adjusting Zero.

**Vibration effect :**

> ±0,25% of span for spans greater than 1/10 of URL.

Frequency 10 to 150Hz, acceleration 39,2m/sec<sup>2</sup> .

**Material fatigue :**

Please consult Fuji Electric.

**Dielectric strength :**

500V AC, 50/60Hz 1 min., between circuit and earth.

**Insulation resistance :**

More than 100MΩ at 500V DC.

**Internal resistance for external field indicator :**

12Ω max. (connected to test terminal CK+ and CK-)

**Performance specifications for square root output**

**Accuracy rating:**

Output	Span	
	over 0.1 × URL	below 0.1 × URL
50 to 100%	±0.065 %	±(0.015+0.05 × 0.1 × URL/Span)%
20 to 50%	±0.163 %	±2.5 × (0.015+0.05 × 0.1 × URL/Span)%
10 to 20%	±0.325 %	±5 × (0.015+0.05 × 0.1 × URL/Span)%

**Max span 1kPa, 6kPa model:**

Output	Accuracy
50 to 100%	±0.1 %
20 to 50%	±0.25%
10 to 20%	±0.5 %

**Temperature effect:**

Effects per 28°C change between the limits of -40°C and +85°C

Range code	Shift at 20% output point
"1" and "2"	± (0.375+0.25 $\frac{URL}{Span}$ )%/28°C
"3" through "9"	± (0.24+0.03125 $\frac{URL}{Span}$ )%/28°C

**Low flow cut-off:**

Customer configurable for any point between 0 to 20% of output

**Physical specifications**

**Electrical connections:**

1/2"-14 NPT, Pg13.5 or M20×1.5

**Process connections:**

1/4"-18 NPT on 54mm centers, as specified.

Meets DIN 19213.

option: 1/2"-14 NPT for oval flanges

**Process-wetted parts material:**

Material code (7th digit in code symbols)	Process cover	Diaphragm	Wetted sensor body	Vent/drain
V	316L SS(*1)	316L SS	316/31803 SS	316 SS
W	316L SS(*1)	Hastelloy-C	316 SS	316 SS
H	316L SS(*1)	Hastelloy-C	Hastelloy-C lining	316 SS
J	316L SS(*1)	316L SS + Gold coating	316SS	316 SS
M	316L SS(*1)	Monel	Monel lining	316 SS
T	316L SS(*1)	Tantalum	Tantalum lining	316 SS

Notes: \*(1) ASTM CF8M

Remark:

Sensor gasket :Viton o-ring or PTFE square section gasket. Availability of above material design depends on ranges and static pressure. Refer to "Code symbols".

**Non-wetted parts material :**

Electronics housing:

Low copper die-cast aluminum alloy finished with polyester coating (standard), or 316 stainless steel, as specified.

Bolts and nuts:

- Cr-Mo alloy (standard) till 420 bar,
- 316 stainless steel for static pressure if 160 bar max.
- SS660 for static pressure > 160 bar.

Fill fluid :

Silicone oil (standard) or fluorinated oil

Mounting bracket :

304 stainless steel

**Environmental protection:**

IEC IP67 and NEMA 6/6P

**Mounting:**

Without mounting bracket : direct mounting on mani-fold (optional)

With optional mounting bracket : for 50mm (2") pipe or direct wall mounting.

**Mass{weight}:**

Transmitter approximately 3.1 to 3.6kg without options.

Add; 0.5kg for mounting bracket

4.5kg for stainless steel housing (option)

## Optional features

### Indicator :

A plug-in analog indicator.  
An optional 5-digit LCD meter with engineering unit is also available.

### Local configurator with LCD display :

An optional 5 digits LCD meter with 3 push buttons can support items as using communication with HHC<sup>(1)</sup>.

### Arrester :

A built-in arrester protects the electronics from lightning surges.  
Lightning surge immunity: 4kV (1.2 × 50μs)

### Oxygen service :

Special cleaning procedures are followed throughout the process to maintain all process wetted parts oil free.  
The fill fluid is fluorinated oil.

### Chlorine service :

The fill fluid is fluorinated oil.

### Degreasing :

Process-wetted parts are cleaned, but the fill fluid is standard silicone oil. Not for use on oxygen or chlorine measurement.

### NACE specification :

Metallic materials for all pressure bound ary parts comply with NACE MR-01-75.  
660 or 660/660 stainless steel bolts and nuts comply with NACE.

### Optional tag plate :

An extra stainless steel tag with customer tag data is wired to the transmitter.

### Vacuum service :

Special silicone oil and filling procedure are applied.

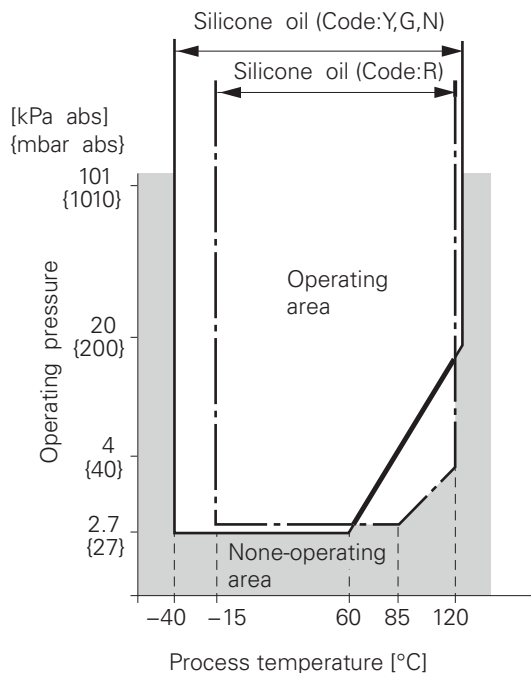

Fig. 1 Relation between process temperature and operating pressure

## ACCESSORIES

### Oval flanges :

Converts process connection to 1/2"-14 NPT in 316L SS.

### Manifolds :

Available in 316 stainless steel and in pressure rating 16MPa or 42MPa.

### Hand held communicator :

(FXW model, refer to datasheet N° EDS8-47)



1	2	3	4	5	6	7	8	9	10	11	12	13	14	15	16	DESCRIPTION
F	K	C					5									<b>Indicator &amp; Arrester</b>
							5	A								Indicator
							5	B								Arrester
							5	C								Initial setting
							5	D								None
							5	J								None
							5	E								None
							5	F								4-20 mA DC
							5	G								None
							5	H								+
							5	K								Yes
							5	1								Yes
							5	2								Yes
							5	3								Yes
							5	4								Yes
							5	5								Yes
							5	6								Yes
																<b>Approvals for hazardous locations (consult FUJI for availability)</b>
								A								None (Standard)
								X								ATEX - Flameproof enclosures (digit 4 = "M, P, R, T" & "W" only)
								K								ATEX - Intrinsic Safety
								D								FM - Explosion-Proof (digit 4 = "P" & "T" only)
								E								CSA - Explosion-Proof (digit 4 = "P" & "T" only)
								H								FM - Intrinsic Safety and Non Incendive
								J								CSA - Intrinsic Safety
								P								ATEX - Type "n" (digit 9 = A, E, 1, 2, 3, 4, 5 & 6 only)
								Q								IECEx - Type "n" (digit 9 = A, E, 1, 2, 3, 4, 5 & 6 only)
								R								IECEx - Flameproof enclosures (digit 4 = "M, P, R, T" & "W" only)
								T								IECEx - Intrinsic Safety
								L								CSA - Explosion-Proof & Intrinsic Safety combined approval (digit 4 = "P" & "T" only)
								M								ATEX - Flameproof enclosures & Intrinsic Safety combined approval (digit 4 = "M, P, R, T" & "W" only)
								N								IECEx - Flameproof enclosures & Intrinsic Safety combined approval (digit 4 = "M, P, R, T" & "W" only)
								V								FM - Explosion-Proof & Intrinsic Safety combined approval (digit 4 = "P" & "T" only)
																<b>Side vent/drain &amp; mounting bracket</b>
																Side
																Mounting
																Vent/drain
																bracket
								A								None
								C								None
								D								Yes, SS
								F								Yes
																Yes, SS
																<b>SS parts</b>
																SS tag plate
																SS housing
								Y								None
								B								Yes
								C								None
								E								Yes
																<b>Special applications &amp; fill fluid</b>
																Treatment
																Fill fluid
								Y								None (std)
								W								Silicone oil
								G								None (std)
								A								Fluorinated oil
								D								Degreasing
								N								Silicone oil
								R								Oxygen service
																Fluorinated oil (only w/digit7=V)
																Chlorine service
																Fluorinated oil (only w/digit 7=H,T,B,U)
																NACE
																Silicone oil
																Vacuum service
																Silicone oil
																<b>Process cover gasket</b>
																Viton
																PTFE square section gasket in SS flange (FEF design)
																PTFE square section gasket in PVDF insert
																<b>Bolts/screws material</b>
																Carbon steel Cr-Mo (standard) M10
																SS 316/316 (bolt/nuts) M10
																Carbon steel Cr-Mo M12 for static pressure > 160 bar
																SS 660/660 (bolt/nuts) M10, and M12 for static pressure > 160 bar
																<b>Special options or design</b>
																special, no code available

Notes\*:

- The thread is M12, if static pressure 300/420 bar
- Turn down of 100:1 is possible, but it should be used at a span greater than 1/40 of the maximum span for better performance.
- Max. static pressure 160 bar for SS 316 bolts/nuts; for static pressure > 160 bar, please specify SS 660 bolts
- Gold coating on wetted measuring cell parts for Hydrogen service - Hydroseal version - gold/ceramic coating is available upon request.
- Process cover with PVDF insert with 1/2"-14 NPT side process connection/no vent drain, other upon request - square section PTFE gasket
  - When no code can be found in the current code symbols, place\* in concerned code digit(s) & add\* in 16 th digit
- Our stainless steel bolts / nuts in SS 660 are in conformity with the NACE requirements and must be used for NACE service
- For the static pressure option 420 bar and process cover gasket PTFE please use only code "R", "T" or "X"
- Process connection on the bottom side.
- Code "D & V" FM approval only possible with electrical connection 1/2"-14 NPT.
- Carbon steel / SS 660 M12 bolting have to be used for static pressure > 160 bar
- Max possible overload pressure on LP side must be ≤ 100 bar

OUTLINE DIAGRAM (unit: mm)

<7th digit code : V, H, M, T>

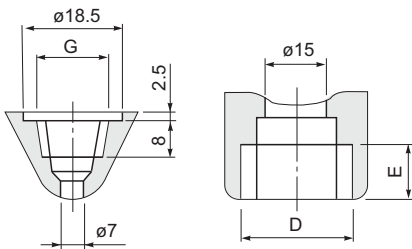
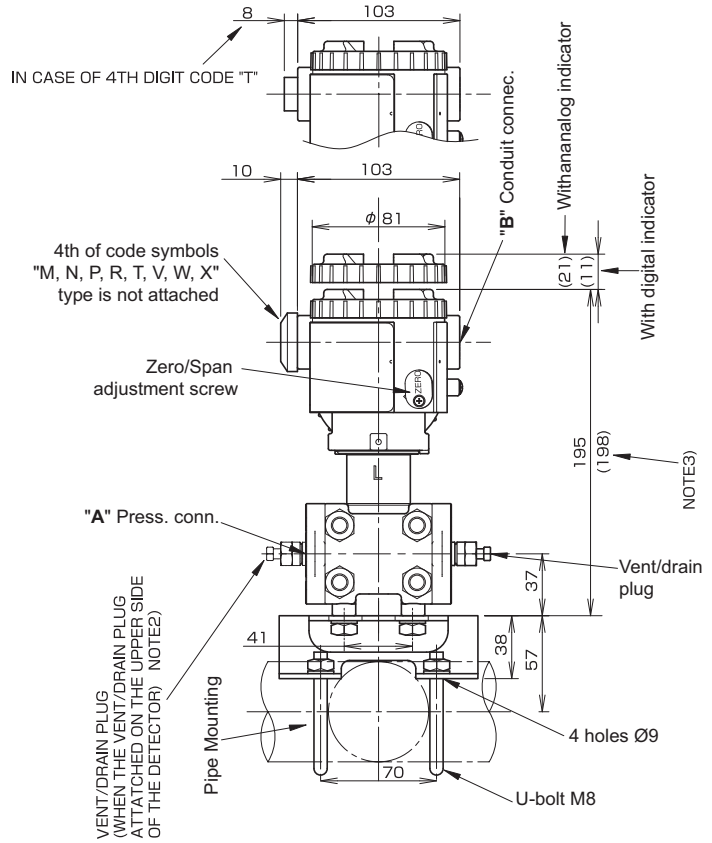
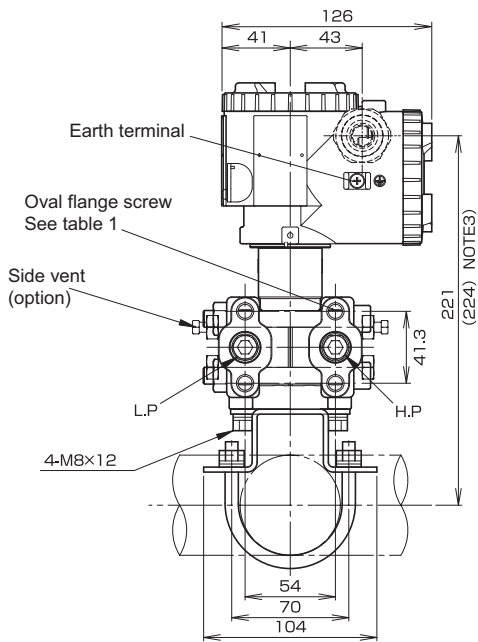

Details of "A"

Details of "B"

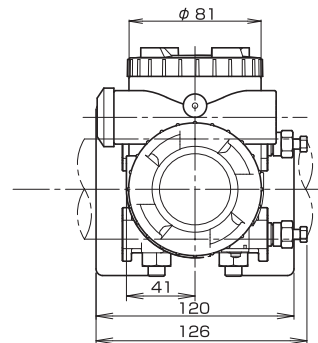

4th digit of the code symbols	Conduit conn.		Press. conn.	Oval frange screw
	D	E	G	
R	M20x1.5	16	1/4-18 NPT	7/16-20UNF
T	1/2-14NPT	16	1/4-18 NPT	7/16-20UNF
V	Pg13.5	10,5	1/4-18 NPT	M10 or M12
W	M20x1.5	16	1/4-18 NPT	M10 or M12
X	Pg13.5	10,5	1/4-18 NPT	7/16-20UNF

TABLE 1

NOTE1) IN CASE OF 10TH CODE "C", ø11 CABLE IS SUITBLE.  
 NOTE2) THE PRESSURE CONNECTOR IS LOCATED ON THE DOWN SIDE SURFACE OF THE DETECTOR, WHEN THE VENT/DRAINPLUG IS ATTACHED ON THE UPPER SIDE OF THE DETECTOR (WHEN THE 21TH DIGIT OF THE CODE SYMBOLS : C).  
 NOTE3) WHEN THE 5TH DIGIT OF THE CODE SYMBOLS "1,2,4" OR THE 7TH DIGIT OF THE CODE SYMBOLS "C,H,M,T"



**EMC Directive (2004/108/EC)**

All models of **FCX** series transmitters type **FCX-All** are in accordance with :

- the harmonized standards:
  - EN 61326-1 : 2006 (Electrical equipment for measurement, control and laboratory use - EMC requirements).
  - EN 61326-2-3 : 2006 (Part 2-3 : Particular requirements - Test configuration, operational conditions and performance criteria for transducers with integrated or remote signal conditioning)

**Emission limits** : EN 61326-1 : 2006

Frequency range (MHz)	Limits	Basic standard
30 to 230	40 dB ( $\mu\text{V}/\text{m}$ ) quasi peak, measured at 10m distance	EN 55011 / CISPR 11 Group 1 Class A
230 to 1000	47 dB ( $\mu\text{V}/\text{m}$ ) quasi peak, measured at 10m distance	

**Immunity requirements** : EN 61326-1 : 2006 (Table 2)

Phenomenon	Test value	Basic standard	Performance criteria
Electrostatic discharge (EDS)	4 kV (Contact) 8 kV (Air)	EN 61000-4-2 IEC 61000-4-2	<b>B</b>
Electromagnetic field	10V/m (80 to 1000 MHz) 3 V/m (1.4 to 2.0 GHz) 1 V/m (2.0 to 2.7 GHz)	EN 61000-4-3 IEC 61000-4-3	<b>A</b>
Rated power frequency Magnetic field	30 A/m	EN 61000-4-8 IEC 61000-4-8	<b>A</b>
Burst	2 kV (5/50 NS, 5 kHz)	EN 61000-4-4 IEC 61000-4-4	<b>B</b>
Surge	1 kV Line to line 2 kV Line to line	EN 61000-4-5 IEC61000-4-5	<b>B</b>
Conducted RF	3 V (150 kHz to 80 MHz)	EN 61000-4-6 IEC61000-4-6	<b>A</b>

**Performance criteria** :

**A** : During testing, normal performance within the specification limits.

**B** : During testing, temporary degradation or loss of function or performance which is self-recovering.

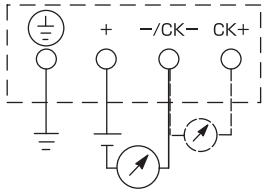
**CONNECTION DIAGRAM**

---

## Fuji Electric

Your distributor:

**Coulton Instrumentation Ltd**

17 Somerford Business Park, Christchurch, BH23 3RU, UK

**Tel:** +44 1202 480 303

**E-mail:** sales@coulton.com

**Web:** www.coulton.com