

FUJI ELECTRIC	Instruction Manual
Micro-controller X Model:PXV4	
INP-TN2PXV4-E	

Fuji Electric Co., Ltd.
 Head Office
 11-2, Osaki 1-chome, Shinagawa-ku, Tokyo, 141-0032 Japan
<http://www.fujielectric.co.jp>

Fuji Electric Instruments Co., Ltd.
 Sales Div. International Sales Dept.
 No.1, Fuji-machi, Hino-city, Tokyo, 191-8502 Japan
 Phone : +81-42-585-6201,6202
 Fax : +81-42-585-6187,6189
<http://www.fic-net.co.jp>

Thank you for your purchasing "Fuji Digital Temperature Controller." Please check that the product is exactly the one you ordered and use it according to the following instructions. (Please refer to a separate operation manual for details.) Dealers are cordially requested to ensure the delivery of this Instruction Manual to hands of the end-users.

NOTICE

The contents of this document may be changed in the future without prior notice.



We paid the utmost care for the accuracy of the contents. However, we are not liable for direct and indirect damages resulting from incorrect descriptions, omission of information, and use of information in this document.

The related documents

Contents	Title	Document No.
Specifications	Catalogue (Data sheets)	ECNO 1125
Operation	Operation Manual	PXV, PXW-1-E

Before using this product, the user is requested to read the following precautions carefully to ensure the safety. Safety precautions must be taken by every user to prevent an accident.

The safety requirements are classified into "warning" and "caution" according to the following interpretation :

 Warning	Suggesting that the user's mishandling can result in personal death or serious injury.
 Caution	Suggesting that the user's mishandling can result in personal injury or damage to the property.

1. Warning

1.1 Installation and wiring

- This equipment intends to be installed with the following conditions.

Operating temperature	-10 to 50 [°C]	
Operating humidity	90%RH or less (Non condensing)	
Installation category	II	Conforming to IEC1010-1
Pollution degree	2	

- Preserve the creepage and clearance as shown below between the temperature sensor and the location which indicates or generates the voltages as shown in the following table.

Failure to maintain these minimum distances would invalidate the EN 61010 safety approval.

Voltage used or generated by the other assemblies	Clearance (mm)	Clearance (mm)
Up to 50Vrms or Vdc	0.2	1.2
Up to 100Vrms or Vdc	0.2	1.4
Up to 150Vrms or Vdc	0.5	1.6
Up to 300Vrms or Vdc	1.5	3.0
Above 300Vrms or Vdc	Contact with sales office.	

} Hazardous voltage

- If the voltage shown above exceeds 50Vdc(i.e. hazardous voltage), the basic insulation is required between all terminals of this equipment and the ground, and supplementary insulation is required for the alarm output.

Isolation class of this equipment is shown below. Be sure check that the isolation class of the equipment satisfies your requirements before installation.

MAINS-INPUTS	BASIC insulation
MAINS-OUTPUTS	BASIC insulation
inputs - outputs (relay, alarm output)	BASIC insulation
inputs - outputs (SSR drive, 4-20mA DC)	Non-insulation

- If there is a danger of a serious accident resulting from a failure or a defect in this unit, provide the unit with an appropriate external protective circuit to prevent an accident.
- The unit is normally supplied without a power switch and fuses.
Make wiring so that the fuse is placed between the main power supply switch and this equipment.
(main power supply: 2 pole breaker, fuse rating: 250V, 1A)
- When wiring the power supply terminal, use vinyl insulated 600 volt cable or equivalent.
- To avoid the damage and failure of equipment, supply the power voltage fitting to the rating.
- To avoid an electric shock and equipment failure, do not turn ON the power before all wiring is completed.
- Be sure to check that the distance is kept to avoid electric shock or firing before turning the power ON.
- Keep away from terminals while the circuit is energized in order to avoid an electric shock and a malfunction.
- Never attempt to disassemble, fabricate, modify, or repair this unit because tampering with the unit may result in a malfunction, electric shock, or a fire.

1.2 Maintenance precautions

- Be sure to turn off the power before this unit is installed or removed in order to avoid an electric shock, malfunction, and fault.
- Regular maintenance is recommended a longer service life of this unit. Some parts of this unit have a limited life span, or they will be deteriorated with the lapse of time.
- One-year warranty is guaranteed for this unit including accessories, provided that the unit is properly used.

2. Caution

2.1 Cautions on installation

Avoid the following places for installation.

- a place where the ambient temperature may reach beyond the range of from 0 to 50°C while in operation.
- a place where the ambient humidity may reach beyond the range of from 45 to 85% RH while in operation.
- a place where a change in the ambient temperature is so rapid as to cause condensation.
- a place where corrosive gases (sulfide gas and ammonia gas, in particular) or combustible gases are emitted.
- a place where the unit is subject directly to vibration or shock.
- a place exposed to water oil, chemicals, steam and vapor.

(if immersed with water, take the inspection by sales office to avoid an electrical and firing)

- a place where the unit is exposed to dust, salt air, or air containing iron particles.
- a place where the unit is subject to interference with static electricity, magnetism, and noise.
- a place where the unit is exposed to direct sunlight.
- a place where the heat may be accumulated due to the radiation of heat.

2.2 Caution on installation on panel

- Insert the mounting bracket (accessory) from the rear side until the main unit is securely fit into the panel. If there should be a play, tighten two screws lightly until the play is eliminated. (Do not tighten the screws excessively because the mounting bracket can be removed from the stopper by the force.)
- The front side of this instrument conforms to NEMA 4X (equivalent with IP66). To ensure the waterproofness between the instrument and the panel, use packings that are provided as accessories in the following manner: (The improper fitting of packings will ruin the waterproofness.)
 - ① As shown in Figure 1, fit a packing to the case of the unit and then insert it in the panel.
 - ② Tighten screws on the fixing frame or fixtures so that no gaps are given between the front of equipment and packing and between panels. Check that there are no deviation and deformation of packing as shown in Fig.3.

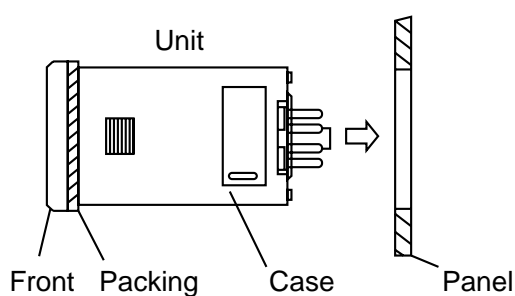

Figure 1

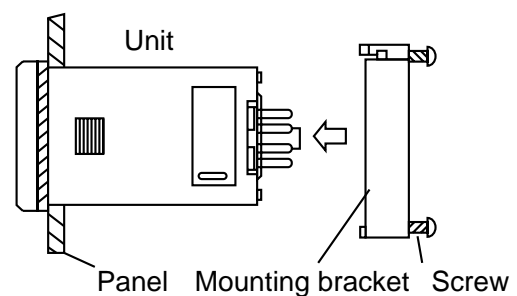

Figure 2

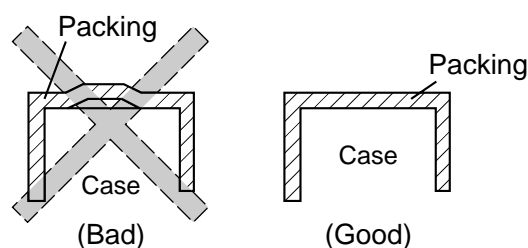

Figure 3

2.3 Precautions in wiring connection

- For the thermocouple sensor type, use thermocouple extension wires for wiring.
For the RTD type, use a wiring material with a small lead wire resistance and no resistance differentials among three wires.
- Keep input lines away from power line and load line to avoid the influence from noise induced.
- For the input and output signal lines, be sure to use shielded wires and keep them away from each other.
- If a noise level is excessive in the power supply, the additional installation of an insulating transformer and the use of a noise filter are recommended. (example: ZMB22R5-11 Noise Filter manufactured by TDK)

Make sure that the noise filter is installed to a place such as a panel that is properly grounded. The wiring between the noise filter output terminal and the instrument power supply terminal should be made as short as possible. None of fuses or switches should be installed to the wiring on the noise filter output side because the filter effect will be degraded by such a installation.

- A better anti-noise effect can be expected by using stranded power supply cable for the instrument. (The shorter the stranding pitch is, the better the anti-noise effect can be expected.)
- For the unit with an alarm against a failure (burn-out) in the heater, use the same power line for connection of the power supplies for the heater and the controller.
- A setup time is required for the contact output when the power is turned on. If the contact output is used as a signal for an external interlock circuit, use a delay relay at the same time.
- Use the supplemental relay since the life is shortened if full capacity load is connected to the output relay. SSR/SSC drive output type is preferred if the output operations occur frequently.

[Proportional interval] relay output: 30 seconds or more, SSR/SSC: one second or more

- If inductive load such as magnetic switches connected as a relay output load, it is recommended to use Z-Trap manufactured by Fuji Electric to protect a contact from switching surge and keep a longer life.

Model : ENC241D-05A (power supply voltage: 100 V)

ENC471D-05A (power supply voltage: 200 V)

Where to install : Connect it between contacts of the relay control output.

Example) PXV4

For TP48X

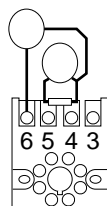

- The SSR/SSC-driven output, an output of 4 to 20 mA DC, is not electrically insulated from internal circuits.

Use a non-grounded sensor for resistance bulb or thermocouple.

2.4 Requirement for key operation/operation in abnormalities

- Prior to the operation, be sure to check alarm functions, since a failure in the proper setting will result in a failure in the proper output of an alarm in case of an abnormality.
- A display of UUUU or LLLL will appear in case of a break in the input. Be sure to turn off the power when a sensor is replaced.

2.5 Others

- Do not use organic solvents such as alcohol and benzene to wipe this unit. Use a neutral detergent for wiping the unit.

For normal usage

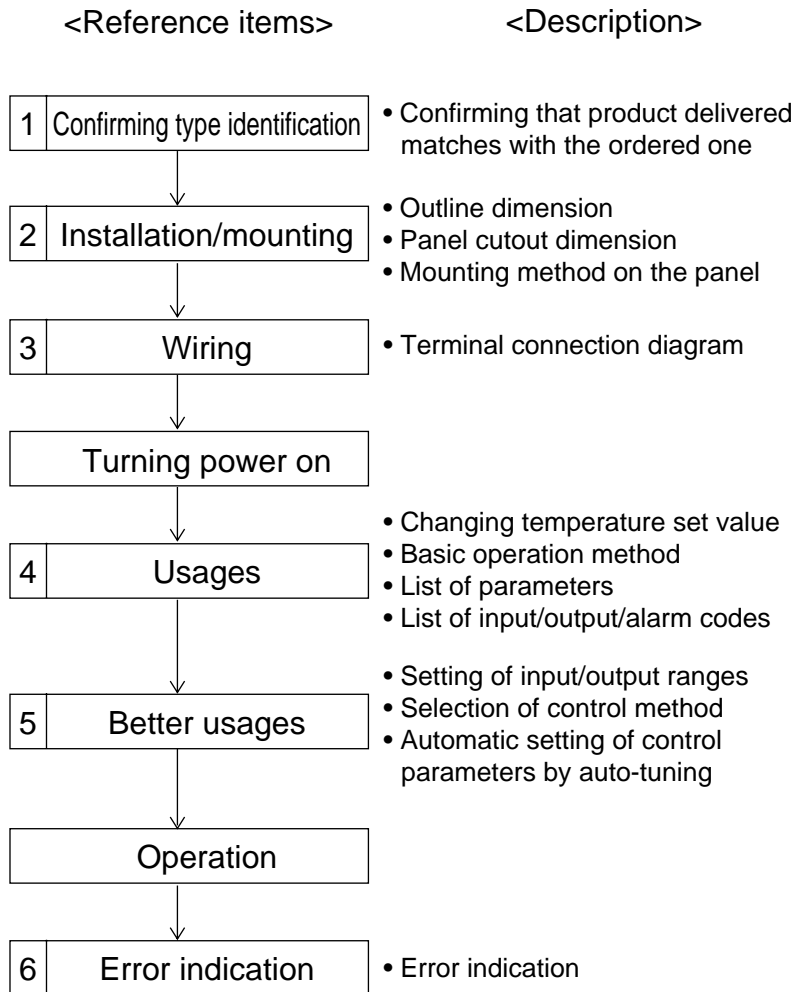

* Wait for about 30 minutes until the controller stabilizes thermally: the operation e.g. measurement should be started 30 minutes after the power is turned on.

1 Confirming type specification

Model Configuration

1	2	3	4	5	6	7	8	9	10	11	12	13	14	Contents
P	X	V				Y	2				0	0		Size of the front 48×48mm
			4											Input type
				T										Thermocouple [°C]
				R										Thermocouple [°F]
				N										RTD (Pt100/IEC)[°C]
				S										RTD (Pt100/IEC)[°F]
				B										4 to 20 mA DC (with 250-Ω I/V conversion resistor) (Note 1)
				A										1 to 5VDC
														Control output
				A										Relay contact output (reverse action)
				B										Relay contact output (direct action)
				C										SSR/SSC driving output (reverse action)
				D										SSR/SSC driving output (direct action)
				E										4-20 mA DC output (reverse action)
				F										4-20 mA DC output (direct action)
														Option
								0						None
								1						Alarm 1 point
								4						Ramp SV
								5						Ramp SV with alarm 1 point
								F						Alarm 2 points
								G						Ramp SV with alarm 2 points
														Instruction manual and power supply voltage
								Y						Japanese, 100 to 240 Vac
								V						English, 100 to 240 Vac
								A						Japanese, 24 Vac/ 24Vdc
								B						English, 24 Vac/ 24Vdc
														Socket
								0						None
								1						with socket TP48X (8-pin)
								2						with socket TP48SB (8-pin)
								3						with socket ATX1NS (8-pin)
								4						with socket TP411X (11-pin)
								5						with socket TP411SBA (11-pin)
														Unit case
														Standard (white case)
													D	NEMA 4X, watertight front, (black case)

Note 1: Install the 250-Ω resistor (accessory) to the terminal.

2

Installation/mounting

Outline Dimensions and Panel Cutout Size

(Unit : mm)

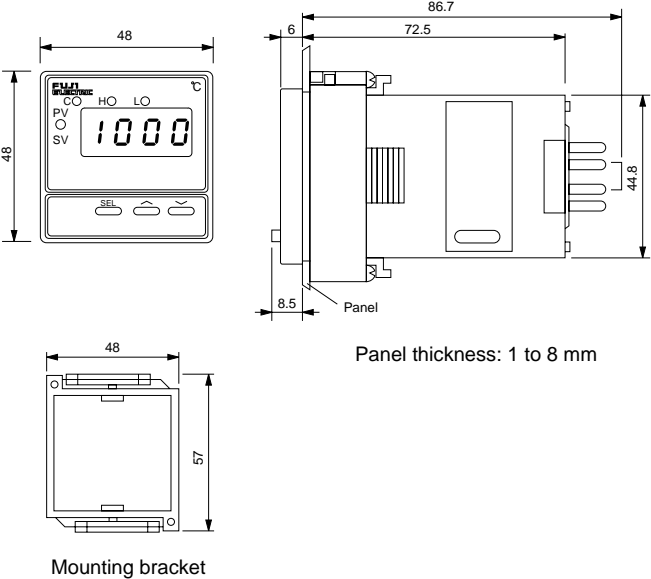
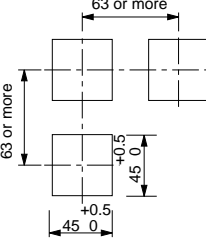
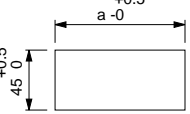
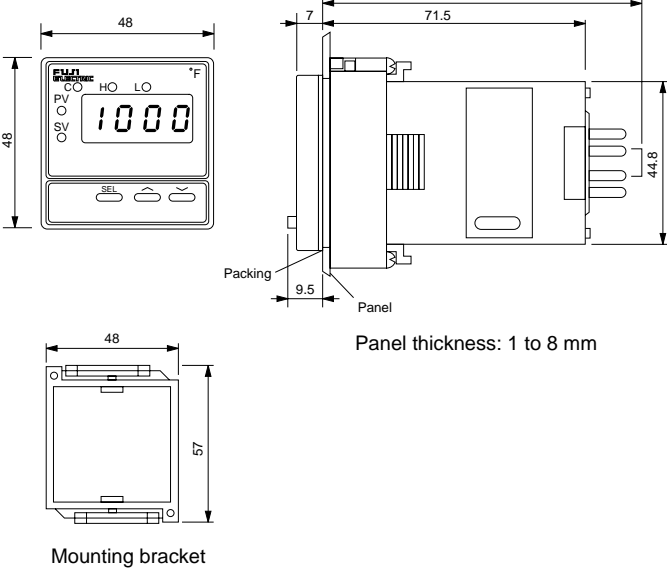
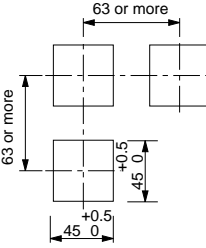
Model	Outline dimensions	Panel cutout dimensions												
<p>PXV4</p>	 <p>Panel thickness: 1 to 8 mm</p>	<p>When installing "n" numbers of units:</p>  <p>For grouped installation Note) See the note below.</p>  <table border="1" data-bbox="1082 1137 1428 1214"> <tr> <td></td> <td>2</td> <td>3</td> <td>4</td> <td>5</td> <td>6</td> </tr> <tr> <td>a</td> <td>93</td> <td>141</td> <td>189</td> <td>237</td> <td>285</td> </tr> </table>		2	3	4	5	6	a	93	141	189	237	285
	2	3	4	5	6									
a	93	141	189	237	285									
<p>Waterproof type PXV4</p>	 <p>Panel thickness: 1 to 8 mm</p>	<p>When installing "n" numbers of units:</p> 												

Note) Caution in the grouped installation: For those models using 200-VAC power supply, the installation of a fan is recommended for the radiation of heat.

For the unit to be installed in the vertical group mode, 100-VAC power supply alone can be used.

3

Wiring

Terminal Connection (for 100 to 240Vac)

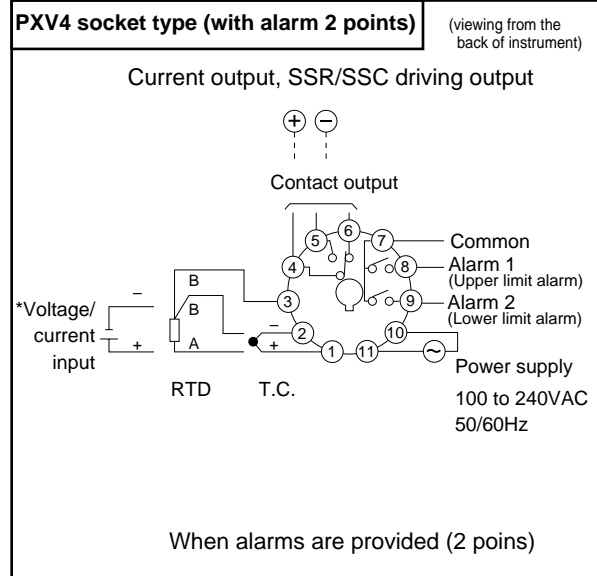
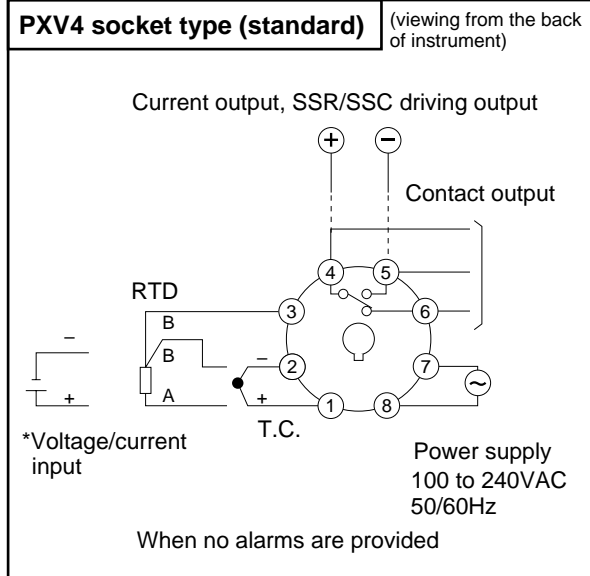

* When allowing an input of 4 to 20 mA DC, install a 250-W resistor (accessory) before using the unit.

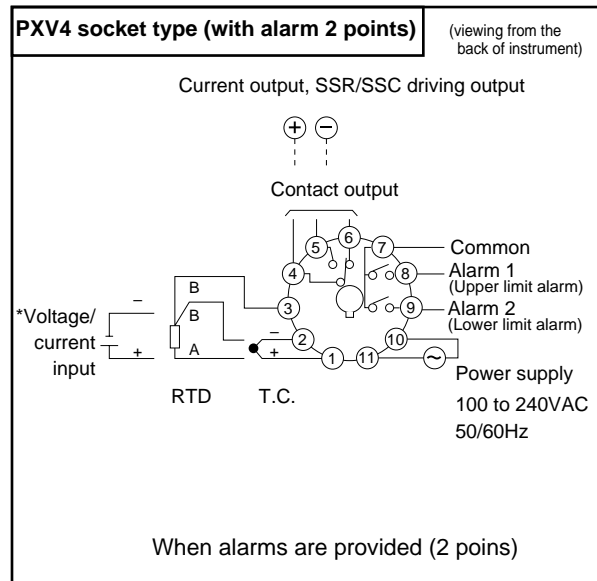
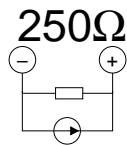

Terminal Connection (for 24Vac / 240Vdc)

Attention : In case of PX*****2-#*#*#* (*: Don't care, #: A or B)

Warning

Be sure to use the rated voltage power supply and polarity.
 This type can be used for 24 VAC and 24VDC power supply only.
 Do not use for 100 to 240VAC power supply.

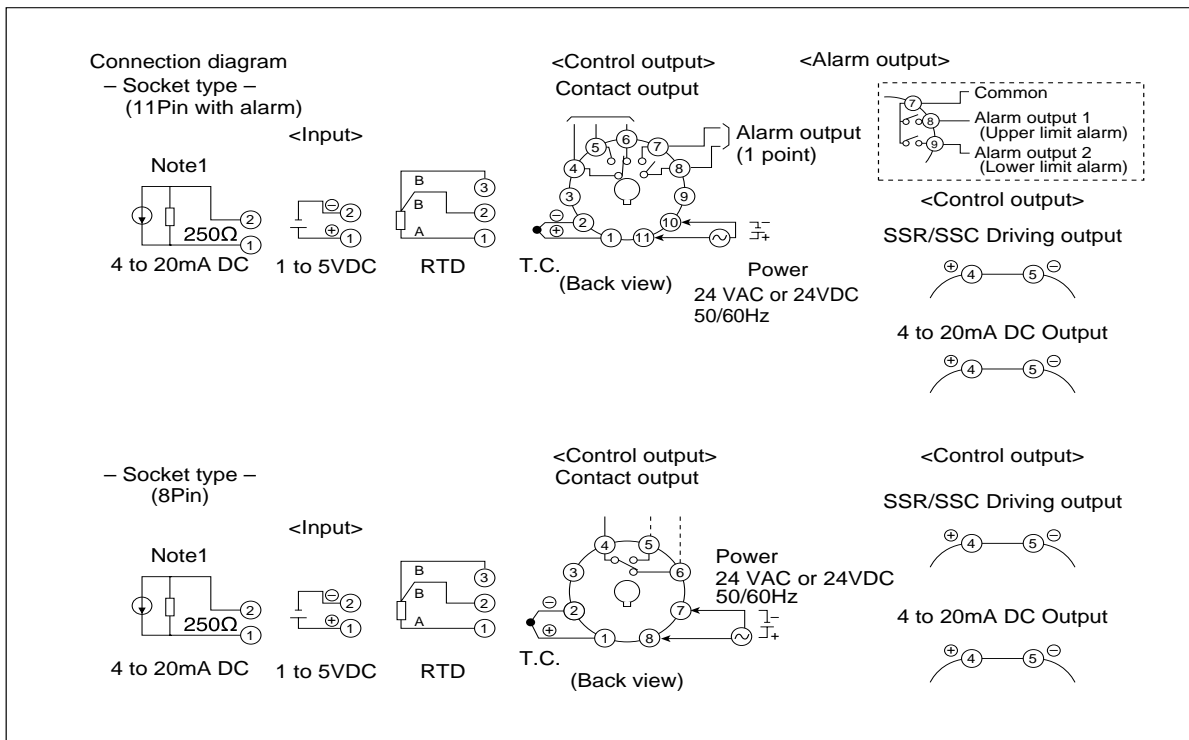

Note 1: Use the 250Wresistance (accessory)

4 Usage (Read before using)

Name of Functional Parts and Function

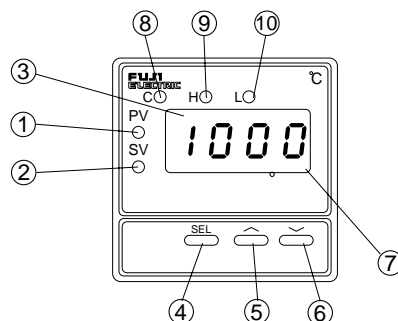

Model : PXV4

Name	Function
① Measured value (PV) indication lamp	Stays on while a measured value (PV) is on the display.
② Set value (SV) indication lamp	Stays on while a set value (SV) is on the display.
③ Measured value (PV)/set value (SV)/ parameter display	Parameter symbols and codes are displayed for a measured value (PV) and set value (SV) and when various parameters are set.
④ Select key	The key for switching to the 1st, the 2nd or the 3rd block parameter, for moving parameters within the 1st block or for switching the display between parameter and the data at the 2nd and the 3rd block.
⑤ UP key	<ul style="list-style-type: none"> • By pressing the key once, the value is increased by 1. Pressing it continuously will increase the value in succession. • For moving parameters within the 2nd and the 3rd block.
⑥ DOWN key	<ul style="list-style-type: none"> • By pressing the key once, the value is decreased by 1. Pressing it continuously will decrease the value in succession. • For moving parameters within the 2nd and the 3rd block.
⑦ Auto-tuning indicator	Blinks while in the PID auto-tuning.
⑧ Control output indication lamp	C: Comes on when the control output is turned on.
⑨ Alarm upper limit indication lamp (Option)	Comes on when the upper limit alarm is activated. It blinks while the alarm value is being set.
⑩ Alarm lower limit indication lamp (Option)	Comes on when the lower limit alarm is activated. It blinks while the alarm value is being set.

[Table 1] Input type codes

Parameter: P-n2

Group	Input type	Code (P-n2)	Group	Input type	Code	
I	RTD	1	II	1 to 5VDC, 4 to 20mA	16	
	· Pt100 (IEC)					
	Thermocouple	2				
	· J					
	· K					3
	· R					4
	· B					5
	· S					6
	· T					7
	· E					8
· N	12					
· PL-II	13					

* In the case of 4-20 mA DC input, use an 250-Ω outboard resistor to input 1-5 VDC.

Note 1) Code may be changed to another that is in the same group.

[Table 2] Input range (Standard range)

Parameter: P-SL, P-SU

		Range of measurement (°C)	Range of measurement (°F)			Range of measurement (°C)	Range of measurement (°F)
RTD (IEC)	Pt100 Ω	0 to 150	32 to 302	Thermo-couple	R	0 to 1600	32 to 2912
	Pt100 Ω	0 to 300	32 to 572		B	0 to 1800	32 to 3272
	Pt100 Ω	0 to 500	32 to 932		S	0 to 1600	32 to 2912
	Pt100 Ω	0 to 600	32 to 1112		T	-199 to 200	-328 to 392
	Pt100 Ω	-50 to 100	-58 to 212		T	-150 to 400	-238 to 752
	Pt100 Ω	-100 to 200	-148 to 392		E	0 to 800	32 to 1472
	Pt100 Ω	-150 to 600	-238 to 1112		E	-199 to 800	-328 to 1472
	Pt100 Ω	-150 to 850	-238 to 1562		N	0 to 1300	32 to 2372
						PL-II	0 to 1300
Thermo-couple	J	0 to 400	32 to 752	DC voltage	DC1 to 5V	-1999 to 9999 (Scaling is possible)	
	J	0 to 800	32 to 1472				
	K	0 to 400	32 to 752				
	K	0 to 800	32 to 1472				
	K	0 to 1200	32 to 2192				

Note 1) Except for the following, the input accuracy is $\pm 0.5\% FS \pm 1 \text{ digit} \pm 1^\circ C$

(Input accuracy does not be guaranteed for the ranges of measurement other than in the table above.)

R thermocouple 0 to 500°C } in these ranges, this controller may display an incorrect process
B thermocouple 0 to 400°C } value due to the characteristic of the sensor.

Note 2) In case a measuring range of -150 to 600°C or -150 to 850°C is used for resistance bulb input, temperatures below -150°C does not be indicated correctly. Therefore, "LLLL" does not appear despite a continuous fall below -150°C.

Note 3) If the resistance bulb or thermocouple is used at a temperature below the lowest value in the measurement range, the input accuracy cannot be guaranteed.

[Table 3] Alarm action type codes

Parameter: P-AH, P-AL

	ALM1 (P-AH)	ALM2 (P-AL)	Alarm type	Action diagram
	0	0	No alarm	
Absolute value alarm	1	1	High alarm	
	2	2	Low alarm	
	3	3	High alarm (with hold)	
	4	4	Low alarm (with hold)	
Deviation alarm	5	5	High alarm	
	6	6	Low alarm	
	7	7	High/Low alarm	
	8	8	High alarm (with hold)	
	9	9	Low alarm (with hold)	
	10	10	High/Low alarm (with hold)	
Zone alarm	11	11	High/Low deviation alarm (ALM 1/2 independent action)	
	--	12	High/Low absolute alarm	
	--	13	High/Low deviation alarm	
	--	14	High absolute/ Low deviation alarm	
	--	15	High deviation/ Low absolute alarm	

Note 1) When you change alarm type, check the alarm set value. A change of alarm action type may cause the alarm set value to be changed, but this is not a malfunction.

Method of setting temperature and parameter

Operating state (PV/SV indication)

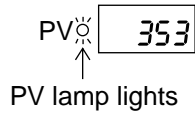

- PV lamp lights, indicating measurement value(PV) and setting value(SV).

To change temperature setting value(SV)

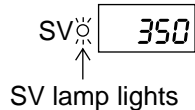

- 1) Press **SEL** key. SV lamp lights and setting value (SV) is indicated.
- 2) Press **▲** or **▼** keys to change value.
- 3) Press **SEL** key or keep it for 3 seconds to register the value.

Cautions in the setting

- After setting data, the data is automatically registered in 3 seconds. The data can be registered as well by pressing the SEL key.
- If the data setting is left as it is for about 30 seconds, the display is automatically returned to the operating state (PV/SV) display.
- Where none of optional functions are incorporated into the unit, optional function parameters will be skipped without appearing on the display.

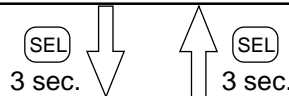

The 1st block parameters

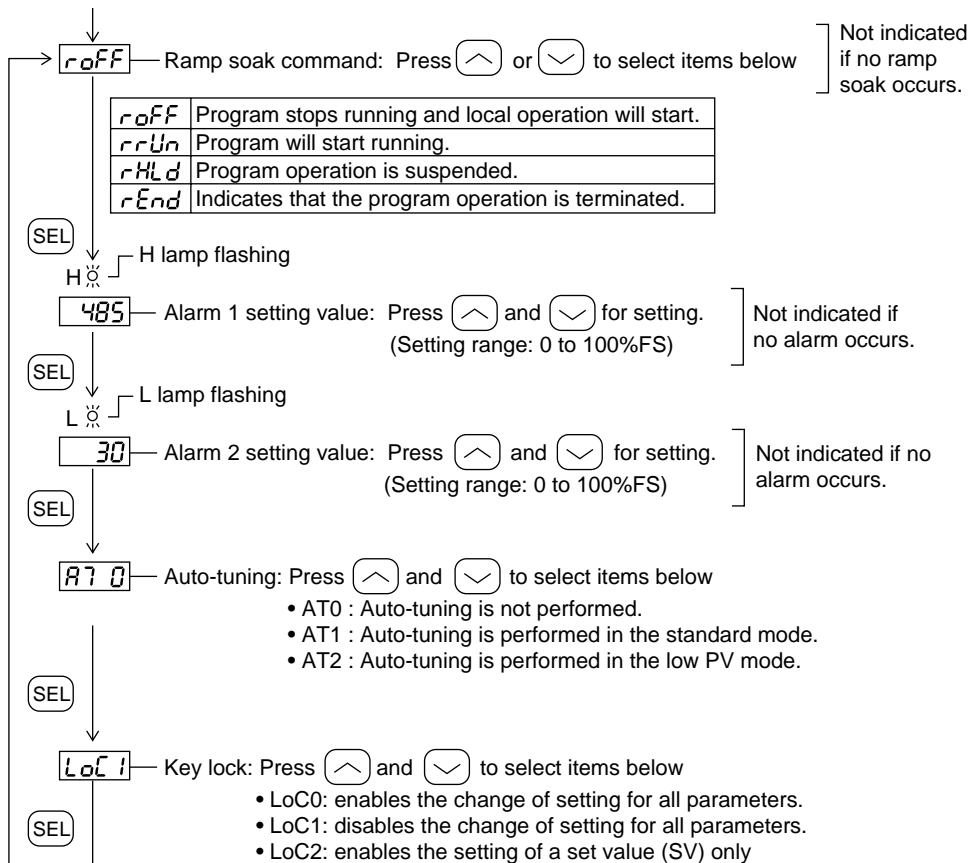

Operating state (PV/SV indication)

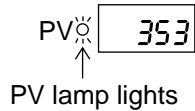

- PV lamp lights, indicating measurement value(PV) and setting value(SV).

To change temperature setting value(SV)

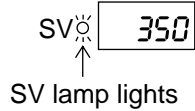

- 1) Press **SEL** key. SV lamp lights and setting value (SV) is indicated.
- 2) Press **▲** or **▼** keys to change value.
- 3) Press **SEL** key or keep it for 3 seconds to register the value.

Cautions in the setting

- After setting data, the data is automatically registered in 3 seconds. The data can be registered as well by pressing the SEL key.
- If the data setting is left as it is for about 30 seconds, the display is automatically returned to the operating state (PV/SV) display.
- Where none of optional functions are incorporated into the unit, optional function parameters will be skipped without appearing on the display.

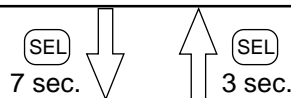

The 2st block parameters

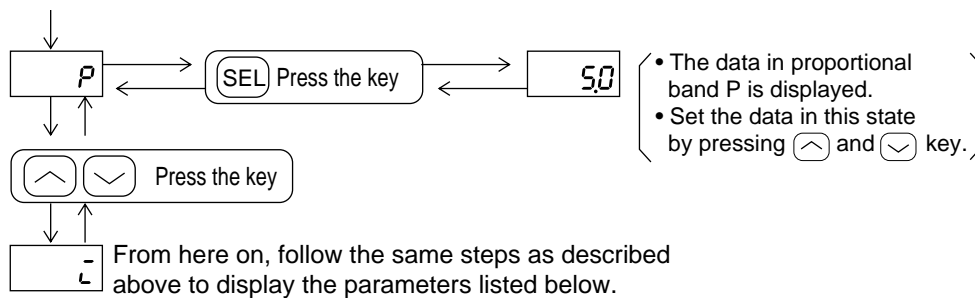

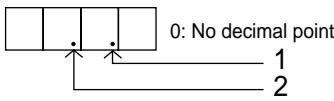
	Parameter display code	Description	Setting range(setting unit)	Reference
P	P	Proportional band (ON/OFF control at 0.0)	0.0 to 999.9%FS	
I	I	Integral action time	0 to 3200 sec.	
d	D	Derivative action time	0.0 to 999.9 sec.	
TC	TC	Proportional time cycle of control output 1	1 to 150 sec.	Note 5, *3
HYS	HYS	Insensitive zone	0 to 50%FS (engineering unit)	
bAL	bAL	Manual reset value	-100.0 to 100.0%	*4
Ar	Ar	Anti-reset wind up	0.0 to 100.0%FS (engineering unit)	*4
$P-n2$	P-n2	Input type setting	0 to 16	Table 1
$P-SL$	P-SL	Setting of lower limit in the range	-1999 to 9999 (engineering unit) Note 3, Note 4	Table 2
$P-SU$	P-SU	Setting of upper limit in the range	-1999 to 9999 (engineering unit) Note 3, Note 4	Table 2
$P-dP$	P-dP	Setting of decimal point position	0 to 2 Note 2, Note 3 	
$P-AH$	P-AH	Alarm type, Alarm type 1	0 to 11	Table 3, *2
$P-AL$	P-AL	Alarm type, Alarm type 2	0 to 15	Table 3, *2
$PVOF$	PVOF	PV offset	-10 to 10%FS (engineering unit)	
$STAT$	STAT	The current position of the program	Can not be set	*1
$SV-1$ to $SV-4$	SV-1 to SV-4	Target value in the 1st ramp to Target value in the 4th ramp	0 to 100%FS (engineering unit)	*1
$TM1r$ to $TM4r$	TM1r to TM4r	Segment time in the 1st ramp to Segment time in the 4th ramp	0:00 to 99:59	*1
$TM1S$ to $TM4S$	TM1S to TM4S	Segment time in the 1st soak to Segment time in the 4th soak	0:00 to 99:59	*1
Mod	MOD	Ramp SV mode	0 Note 1	*1

Note 1) Always set to 0 before using.

Note 2) 2 is valid only if voltage and current are applied.

Note 3) When P-SL/P-SU/P-dP is changed, check that all the parameters including the SV are properly assigned.
(They may have change)

Note 4) Set values so that P-SL < P-SU.

Note 5) The setting of 0 is for current output.

Don't set 0 at contact or SSR driving output.

It is recommended more than 30 at contact or more than 1 at SSR driving output.

*1: Not indicated without ramp/soak.

*2: Not indicated without alarm.

*3: Not indicated for current output.

*4: Not indicated at shipment from factory.

Operating state (PV/SV indication)

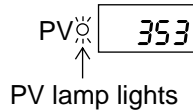

- PV lamp lights, indicating measurement value(PV) and setting value(SV).

To change temperature setting value(SV)

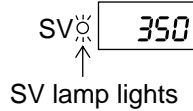

- 1) Press **SEL** key. SV lamp lights and setting value (SV) is indicated.
- 2) Press **▲** or **▼** keys to change value.
- 3) Press **SEL** key or keep it for 3 seconds to register the value.

Cautions in the setting

- After setting data, the data is automatically registered in 3 seconds. The data can be registered as well by pressing the SEL key.
- If the data setting is left as it is for about 30 seconds, the display is automatically returned to the operating state (PV/SV) display.
- Where none of optional functions are incorporated into the unit, optional function parameters will be skipped without appearing on the display.

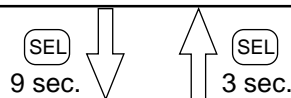

The 3rd block parameters

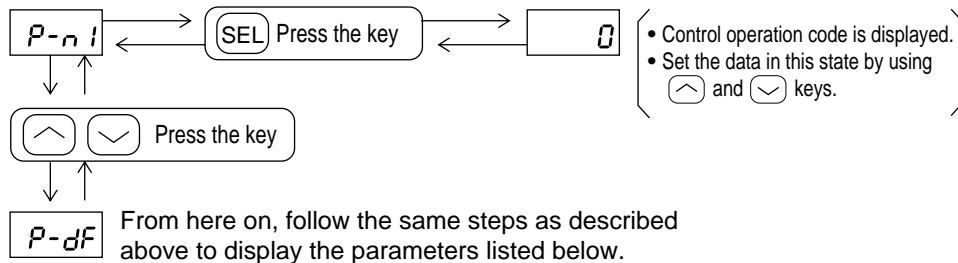

	Parameter display code	Description	Setting range (Setting unit)	Reference
P-n!	P-n1	Specifying control operation	0 to 19	Table 4
P-dF	P-dF	Input filter (Time constant)	0.0 to 900.0 sec.	
P-An	P-An	Alarm insensitive zone	0.0 to 50.0%FS (engineering unit)	*1
FUZY	FUZY	Specifying control method	OFF: PID control ON : FUZZY control	
dSP1 to dSP7	dSP1 to dSP7	Specifying parameter mask	0 to 255	Note 1

Note 1) If you miss setting to dSP1 to dSP7, any parameters that you want to see don't appear. Before you change them, record the current value of them. Take care enough to change them.

*1: Not indicated without alarm.

[Table 4] Control action codes

Parameter: $P-n1$

Code (P-n1)	Output type	Control action	Burn-out direction
		Output 1	Output 1
0	Single	Reverse action	Lower limit
1			Upper limit
2		Direct action	Lower limit
3			Upper limit

[Burn-out direction]

Output direction if input is outside range or has an error.

Lower limit: OFF or 4mA or less

Upper limit: ON or 20mA or more

5

Useful usage of the equipment

1 Setting the input

* Skip this procedure if specified when you order.

① Is the input sensor type same as what you use ?

Select the sensor you use from those in Table 1, and set it in the parameter P-n2.

(Example) For T thermo-couple, set P-n2 to "7".

(Note) Changing between resistance bulb and the thermo-couple is allowed, though that between 1 to 5 VDC (4 to 20mA DC) and thermo-couple/resistance bulb is not allowed.



② Is setting of input temperature range suitable for the sensor you use?

Standard range to each sensor is shown in Table 2. Select the temperature range suitable for the equipment you use, set lower/upper limit values to P-SL/P-SU respectively.

(Example) Temperature range 0 to 800 [°C] set P-SL and P-SU to 0 and 800 respectively.

(Note) Standard range is recommended to set though other setting is available.

(Note) No standard range is given if 1 to 5VDC(4 to 20mA DC) are input.
Any upper/lower limits can be set(-1999 to 9999, and lower limit < upper limit)

2 Setting of controls

* Read if the control doesn't work as you expect.

① Objective of control(heating or cooling applied?)

Objective	Operation scheme	Description	Method
Heating	Reverse	Increased measurement value will decrease operational output value.	Set parameter P-n1 to 0 or 1. (Refer to Table 4)
Cooling	Direct	Increased measurement value will increase operational output value.	Set parameter P-n1 to 2 or 3. (Refer to Table 4)



② Types of control (ON/OFF, PID, fuzzy)

Type of control	Description	Method
ON/OFF control (2 position control)	Output takes either ON (100%) or OFF (0%). (Suitable when frequent output switching is inconvenient.)	Parameter P is set to 0.0. *Refer to "5-1 ON/OFF control"
PID control	Output is calculated with PID parameters, outputting 0 to 100% with setting proportional period (TC) as 100%. Control with less overshoot is available.	Perform the auto-tuning to automatically calculate an optimal PID (manual operation is also available). *Refer to "5-2 Auto-tuning".
Fuzzy control	Fuzzy operation is added to PID providing control with less overshoot.	Set the parameter FUZY to ON. Perform the auto-tuning (same as PID control).

5-1 ON/OFF (two position) control

- Output ON/OFF is determined according to which of PV or SV is larger.
- Set parameter P to 0 for selecting the two- position control.
- Set the operation insensitive zone (hysteresis) to avoid an output chattering near PVSV. (setting at shipping: HYS=1)

- Parameter setting and operation example

Example 1: Reverse action

Parameter	Setting value
P	0.0
P-n1	0 (or 1)
HYS	Any value

Relationship of PV and SV	Output
$PV > SV$	OFF
$PV < SV$	ON

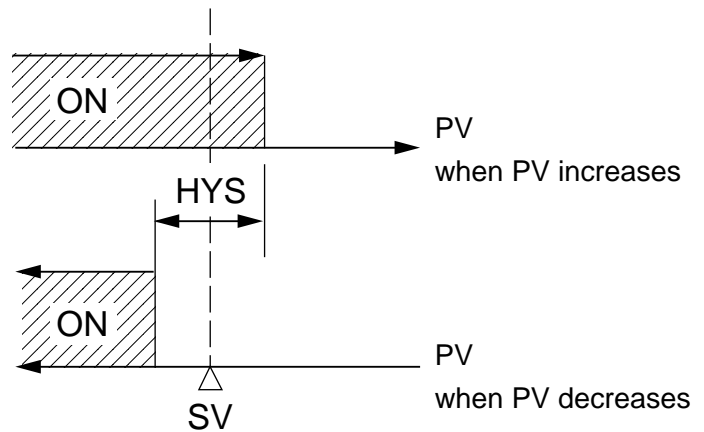

Example 2: Direct action

Parameter	Setting value
P	0.0
P-n1	2 (or 3)
HYS	Any value

Relationship of PV and SV	Output
$PV > SV$	ON
$PV < SV$	OFF

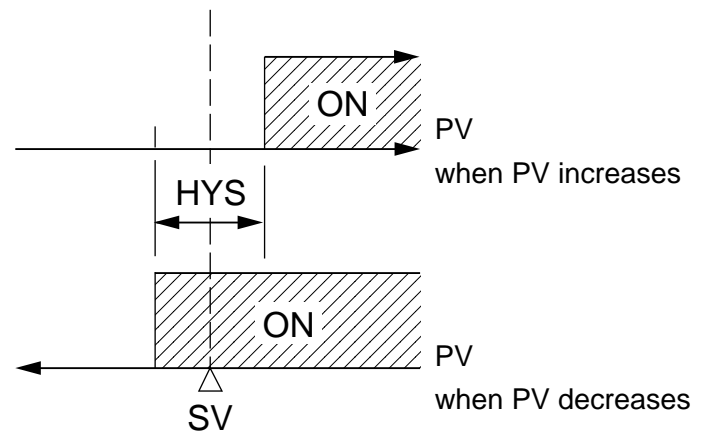

5-2 Auto-tuning (AT)

The auto-tuning is automatic measurement, computation, and setting of the P.I.D. constant that are performed by the micro-controller. Prior to the auto-tuning, complete the setting of input range (P-SL, P-SU, P-dP), a set value (SV), alarm setting (H,L), and proportional time cycle (TC).

How to start the auto-tuning

Set the parameter, AT to either "1" or "2" by using \triangleleft or \triangleright key. The auto-tuning starts automatically after 3 seconds. Then the point indicator at the lower right will start blinking. When auto-tuning ends, parameter AT is automatically set to 0 after flashing at decimal point of digit 1 disappears.

	When auto-tuning is not performed or when it is cancelled	Standard type (auto-tuning on the basis of SV)	Low PV type (auto-tuning on the basis of SV-10%FS)
Setting code (AT)	0	1	2

① Standard type (AT=1)

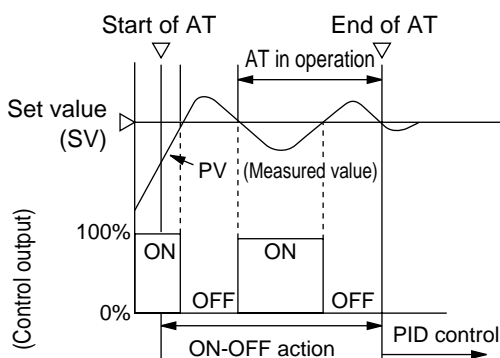

② Low PV type (AT=2) : Overshoot decreases when tuning is performed.

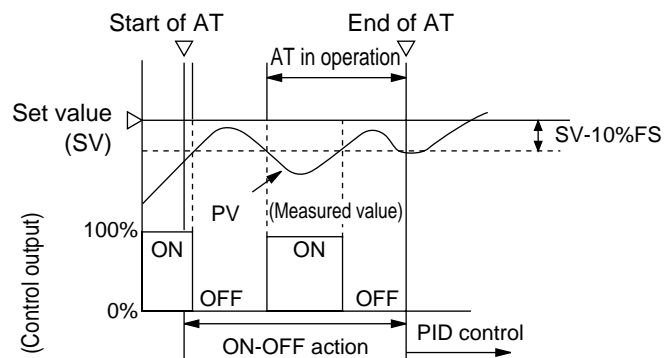

- The P.I.D. parameter calculated by auto-tuning, will be retained even if the power is turned off. If, however, the power is turned off in the auto-tuning, you must restart the auto-tuning.
- The PV may be changed greatly depending on the process, because the control output is ON/OFF action in the auto-tuning. So, do not use the auto-tuning if the process does not allow a significant variation of PV.
Also, the auto-tuning should not be used in a quick-responsive process such as pressure control and flow control.
- If the auto-tuning fails to complete in four hours, an abnormality in the auto-tuning may be suspected. In this case, recheck the wiring, control output operations (normal and reverse action), and parameters such as the input sensor type.
- Carry out the auto-tuning again when the SV is significantly changed, parameter P-SL, P-SU or P-dP is changed or a controlled equipment operation is changed.
- Figures ① and ② show the behavior of PV during the auto-tuning.
- Perform the auto-tuning also when fuzzy control is selected in the control type setting.

5-3 bAL and Ar function

Note: The parameters bAL and Ar disappear at shipment.

you need to set to appear below, "Switching bAL and Ar to appear or to disappear.

- 1) These are functions to suppress overshoot.
- 2) If they aren't optimum value, sometime you don't get the good control. Usually it is not necessary to set them.
- 3) "Ar" is automatically calculated and set by "Auto tuning".

1 bAL

This is added as offset to MV' that PID calculate from PV and SV.

This is MV after calculation above.

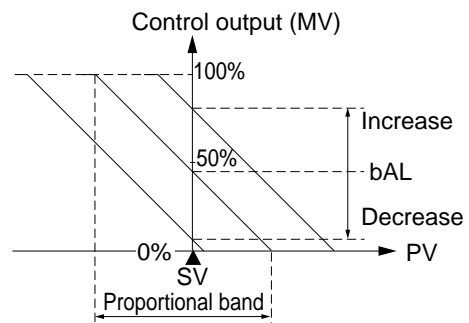
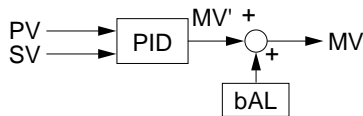

2 Ar

The "Ar" limits the integral range. The

integral range is $SV \pm Ar$.

Integral action don't work when PV is out of the range of $SV \pm Ar$.

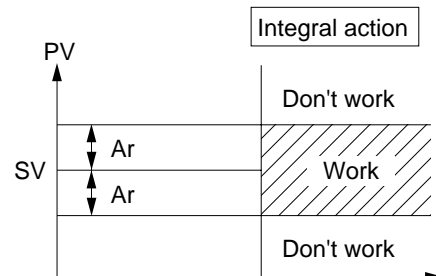

Switching bAL and Ar to appear or to disappear

1 Switch to appear

- ① Display the "dSP2" of the third block parameter and then subtract 128 from current value.
- ② Display the "dSP3" of the third block parameter and then subtract 1 from current value.

2 Switch to disappear

- ① Display the "dSP2" of the third block parameter and then add 128 to current value.
- ② Display the "dSP3" of the third block parameter and then add 1 to current value.

6 Read if the indication is abnormal.

Displays in abnormalities

This unit has a display function to indicate several abnormalities. If an abnormality occurs, eliminate the cause of abnormality immediately. After the cause is eliminated, turn off the power once before the power is turned on.

Display	Cause	Control output
UUUU	<ul style="list-style-type: none"> ① when the thermocouple sensor is burnt out. ② when the RTD (A) is burnt out. ③ when the PV value exceeds the upper limit value of the range + 5% FS. 	<ul style="list-style-type: none"> ① when the burn-out control output is set for the lower limit (standard): OFF or 4 mA or less
LLLL	<ul style="list-style-type: none"> ① when the RTD (B or C) is burnt out. ② when the RTD (between A and B, or between A and C) is shorted. (Note) ③ when the PV value is below the lower limit value of the range -5% FS. ④ when the 1 to 5 VDC wiring is opened or shorted. 	<ul style="list-style-type: none"> ② when the burn-out control output is set for the upper limit: ON or 20 mA or larger
LLLL	<ul style="list-style-type: none"> ① when a PV value is below -199.9. 	<p>The control is continued.</p> <p><i>Note) The control is continued until the value reaches -5% FS or less.</i></p> <p><i>The burn-out will take place when the value reaches -5% FS or less.</i></p>
HB lamp ON	The heater is burnt out.	The control is continued.
Err	When P-SL/P-SU setting is improper.	OFF or 4mA or less
FAL7	Fault in the unit	Undefined (Don't use this controller immediately.)

Note : In case a measuring range of -150 to 600° C or -150 to 850° C is used for resistance bulb input, control will be continued without "LLLL" display.

Specification

Power voltage:	100 (- 15%) to 240VAC (+10%), 50/60Hz or 24VDC/24VAC ($\pm 10\%$), 50/60Hz
Power consumption:	15VAC or less/240VAC
Sensor input:	Thermocouple, 3-wire resistance bulb, 1 to 5VDC
Control method:	PID or fuzzy PID or ON/OFF (two positions)
Relay output:	1C contact, 220VAC/30VDC 3A (resistive load) mechanical life ; 10 million times or over (no load) electrical life ; 100 thousands times or over (rating load)
SSR/SSC driving output: (voltage pulse output)	ON: 15 to 30VDC OFF: 0.5VDC or less maximum current ; 60mA or less When 2 point alarm 25mA or less
DC4-20mA output:	Allowable load resistor 600 Ω or less
Alarm output:	Relay contact (1a contact) 220VAC/30VDC 1A (resistive load)
Operating ambient temperature:	-10 to 50°C
Operating ambient humidity:	90%RH or less (no condensation)
Preservation temperature:	-20 to 60°C
Operating environmental condition:	Installation category II, contamination degree 2 Warm-up time: 30 minutes or more

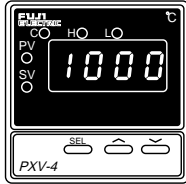

Micro controller X

Type: PXV, PXW

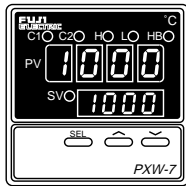

OPERATION MANUAL

Contents

1. Operating Parts and Functions	1
2. Operation	2
2-1 Parameter Table	2
2-2 Basic operation	4
2-3 Parameter functions and setting method	5
Setting of set value (SV)	5
Upper limit alarm (ALM1) setting (option)	6
Lower limit alarm (ALM2) setting (option)	7
Heater burnout alarm (option)	8
Auto-tuning	10
Key lock	11
Setting of proportional band	12
Integral time	13
Derivative time	14
Setting of proportional cycle of control output 1	15
2-position action hysteresis width	16
Cooling side proportional cycle of control output 2	17
Cooling side proportional band coefficient	18
Shift of cooling side proportional band	19
Output convergence value, Anti-reset wind up	20
Setting of input type	21
Lower limit of measurement range and set value (SV)	22
Upper limit of measurement range and set value (SV)	22
Setting of decimal point position	23
Setting of lower limit alarm (ALM2) action type (option)	24
Setting of upper limit alarm (ALM1) action type (option)	24
PV offset	26
SV offset	27
Selection of measurement input °C/°F	28
Program status display	29
Setting of control mode	30
Input filter constant	31
Alarm hysteresis width (option)	32
Setting of RCJ compensation	33
Output 1 lower limit setting	34
Output 1 upper limit setting	34
Output 2 lower limit setting	34
Output 2 upper limit setting	34
Setting of operation mode of output limiter	35
Skipping of parameter display	36
FUZY control setting	37
User's adjust zero adjustment, User's adjust span adjustment	38
Setting of ramp/soak control (ProG) (option)	39
3. Troubleshooting	40

Operating Parts and Functions

Fig. 1-1 shows the outline of the front panel of the unit.

On the front of the unit, there are PV/SV digital indication lamps, condition indication lamps and setting keys. Table 1-1 shows the functions of these operating parts. Before using the unit, be sure to understand the functions of the operating parts.

For details of setting parameters, refer to Chapter 2 of this manual.

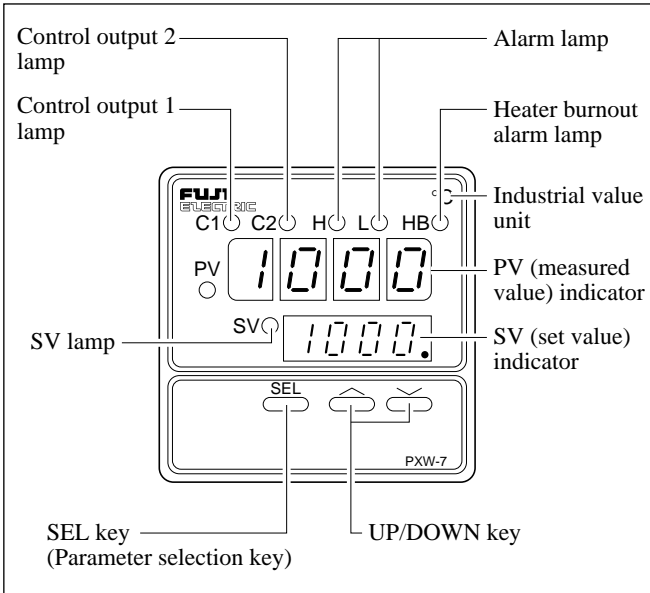



Fig. 1-1

Name	Function
Control output 1 lamp	Lights at ON of control output 1.
Control output 2 lamp	Lights at ON of control output 2.
Alarm lamp	Lights at alarm detection. Alarm output is ON at the same time.
Heater burnout alarm lamp	Lights at detection of heater burnout. Heater burnout alarm output is ON at the same time.
PV (measured value) indicator	Indicates measured values.
SV (set value) indicator	Indicates set values. Also indicates parameters and data at setting of parameters.
“SEL” key	Used for selection of SV/PV display, parameter block, parameters, and indication of parameter values.
“  ”, “  ” key	Used to change of SV value, call of parameter and parameter setting.
SV lamp	Lights when set value (SV) is displayed at the lower stage. Lamp is OFF when parameter or data are indicated.

The setting of set values (SV) and internal parameters of the Micro Controller X are explained in the following.

2-1 Parameter Table

On Micro Controller X, parameters are classified into No. 1, No. 2 and No. 3 blocks according to operation frequency, No. 2 and No. 3 blocks are used for initial setting and whenever necessary.

① No. 1 block parameter table

Parameter display symbol	Name		Description	Initial set value prior to delivery	User's set value	Parameter mask DSP	Page
<i>ProG</i>	ProG	Lamp soak control roFF: Stop rrUn: Start rHLd: Pause	Lamp soak start/stop	roFF		1-1	39
<i>H</i>	H	Upper limit alarm	Used to set upper limit operation of alarm. Setting within input range is possible (option).	10		1-2	6
<i>L</i>	L	Lower limit alarm	Used to set lower limit operation of alarm. Setting within input range is possible (option).	10		1-4	7
<i>Hb</i>	HB	Heater burnout alarm	Used to set value of heater burnout detection (option). (Setting range: 1.0 to 50.0A) [Alarm function OFF at 0]	0.0		1-8	8, 9
<i>AT</i>	AT	Auto-tuning	Used to set PID parameters by auto-tuning. 0: None (auto-tuning released or not executed) 1: Execution (standard type: auto-tuning is executed by SV value) 2: Execution (low PV type: auto-tuning is executed at -10FS of SV value)	0		1-16	10
<i>LoC</i>	LoC	Key lock	Designates enable or disable to change the parameter setting. 0: Change of all parameter setting is possible. 1: Change of all parameter setting is impossible. 2: Change of set value (SV) only is possible.	0		1-32	11

② No. 2 block parameter table

Parameter display symbol	Name		Description	Initial set value prior to delivery	User's set value	Parameter mask DSP	Page
<i>P</i>	P	Proportional band	Setting range: 0.0 to 999.9% (for input range)	5.0		1-128	12
<i>I</i>	I	Integral time	Setting range: 0.0 to 3200 sec.	240		2-1	13
<i>d</i>	D	Derivative time	Control stability is enhanced with input change. It resets quickly with change of small deviation at large derivative time (D). (Setting range: 0.0 to 999.9 sec.)	60.0		2-2	14
<i>TC</i>	TC	Control output 1 proportional cycle	Used to set control output proportional cycles. (Setting range: 1 to 150 sec.)	Contact output: 30 SSR/SSC drive output 2		2-4	15
<i>HYS</i>	HYS	2-position action hysteresis width	Used to set hysteresis width at 2-position action. (Setting range: 0.0 to 50.0%FS)	1		2-8	16
<i>TC2</i>	TC2	Control output 2 proportional cycle	Used to set proportional cycle of cooling side control output (option). (Setting range: 1 to 150 sec.)	Contact output: 30 SSR/SSC drive output 2		2-16	17
<i>Cool</i>	Cool	Cooling side proportional band coefficient	Used to set cooling side proportional band coefficient (option). (Setting range: 0.0 to 100.0) The setting of 0 will lead to ON-OFF operation.	1.0		2-32	18
<i>db</i>	db	Cooling side proportional band shift	Used to shift cooling side output value (option). (Setting range: -50.0 to +50.0)	0.0		2-34	19
<i>bAL</i>	BAL	Output convergence value	Function to suppress overshoot.	Single: 0.0 Dual: 50.0		2-128	20
<i>AR</i>	AR	Antireset wind up	Used suppress overshoot due to integral action. (Setting range: 0 to 100%FS)	100%FS		3-1	20

Items shown in are not displayed. If necessary, they are able to be displayed and set by using the dsp1 to dsp7 function of No.3 block parameter.

② No. 2 block parameter table (continued from preceding page)

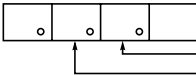
Parameter display symbol	Name		Description	Initial set value prior to delivery	User's set value	Parameter mask DSP	Page
P-n2	P-n2	Setting of input type	Setting of input type	As per ordering specification		3-2	21
P-SL	P-SL	Setting of lower limit range	Setting of lower limit input range	As per ordering specification		3-4	22
P-SU	P-SU	Setting of higher limit range	Setting of higher limit input range	As per ordering specification		3-8	22
P-dP	P-dP	Setting of decimal point position	Setting decimal point position of PV/SV display. 	As per ordering specification		3-16	23
P-AH	P-AH	Setting of higher limit alarm (ALM1) type	Setting of alarm action type	5		3-32	24, 25
P-AL	P-AL	Setting of lower limit alarm (ALM2) type	Setting of alarm action type	9		3-64	24, 25
PVOF	PVOF	PV offset	Shift of input value (PV) display. (Setting range: -10 to 10%FS)	0		3-128	26
SVOF	SVOF	SV offset	Shift of set value (SV) display. SV display remains unchanged. (Setting range: -50 to 50%FS)	0		4-1	27
P-F	P-F	Selection of unit °C/°F of measured value input	Measured value is selected, so other parameters need to be changed. °C display: C °F display: F	As per ordering specification		4-2	28
STST	STST	Ramp/soak present position display	Used to display present ramp/soak position (option)	OFF		4-4	29
SV-1 SV-4	SV-1 SV-4	No.1 to No.4 target value	Used to set ramp/soak target value (option). (setting range: 0 to 100%FS)	0%FS		4-8 4-64 5-2 5-16	29
TM1r TM4r	TM1r TM4r	No.1 to No.4 ramp segment time	Used to set time for segment of ramp (option). (setting range 0 to 99h59m)	0.0		4-16 4-128 5-4 5-32	29
TM1S TM4S	TM1S TM4S	No.1 to No.4 soak segment time	Used to set time for segment of soak (option). (setting range: 0 to 99h59m)	0.0		4-32 5-1 5-8 5-64	29
Mod	Mod	Ramp/soak function mode setting	Setting of output at power ON start and end. at power OFF, and setting of repeat action.	0		5-128	-

③ No. 3 block parameter table (continued from preceding page)

Parameter display symbol	Name		Description	Initial set value prior to delivery	User's set value	Parameter mask DSP	Page
P-n1	P-n1	Setting of control method	Setting of normal/reverse action of set output and burnout direction.	As per ordering specification		6-2	30
P-dF	P-dF	Input filter parameter	Setting of input filter parameter (second) (Setting range: 03.0 to 900.0 sec.)	5.0		6-4	31
P-An	P-An	Setting of alarm hysteresis	Setting of alarm output ON-OFF hysteresis width (Setting range: 0 to 50%FS)	1		6-8	32
RCJ	RCJ	RCJ compensation setting	on: RCJ compensation ON (cold contact compensation is performed) off: RCJ compensation OFF (cold contact compensation is not performed)	on		6-16	33
PLC1	PLC1	Output 1 lower limit setting	Setting range: -3.0 to 103.0%	-3.0		6-32	34
PHC1	PHC1	Output 1 higher limit setting	Setting range: -3.0 to 103.0%	103.0		6-64	34
PLC2	PLC2	Output 2 lower limit setting	Setting range: -3.0 to 103.0%	-3.0		6-128	34
PHC2	PHC2	Output 2 higher limit setting	Setting range: -3.0 to 103.0%	103.0		7-1	34
PCuT	PCuT		Peculiar parameter for device. Do not use.	-		7-2	35
FUZY	FUZY	FUZY control setting	ON: FUZY control is performed. OFF: Normal PID control is performed.	OFF		7-4	37
ADJO	ADJO	User adjust zero adjustment	Used for shifting input zero side by user adjust function.	0		7-16	38
ADJS	ADJS	User adjust span adjustment	Used for shifting input span side by user adjust function.	0		7-32	38
OUT	OUT	Output value (MV) display	Display of present output value (MV)	-		7-64	-
dSP1 dSP7	dSP1 dSP7	Parameter skip	Setting of parameter display "yes or no"	Setting is made according to code symbol		-	36

2-2 Basic operation

① Condition at power ON

Operation	Description	Display	
Power ON	Display at power ON is shown at right.	PXV	PV <input type="text"/> <input type="text"/> <input type="text"/> <input type="text"/> SV <input type="text"/> <input type="text"/> <input type="text"/> <input type="text"/>
		PXW	PV <input type="text"/> <input type="text"/> <input type="text"/> <input type="text"/> SV <input type="text"/> <input type="text"/> <input type="text"/> <input type="text"/>

② Selection of parameter

Basic operation of PXV/W is shown below. When PXV4 (1 stage display type) is used, PV/SV is displayed on the one stage display. In this case, PV/SV display is selected by pressing [SEL] key.

If the unit is not operated for 30 seconds, the display is set to PV/SV display just after power ON.

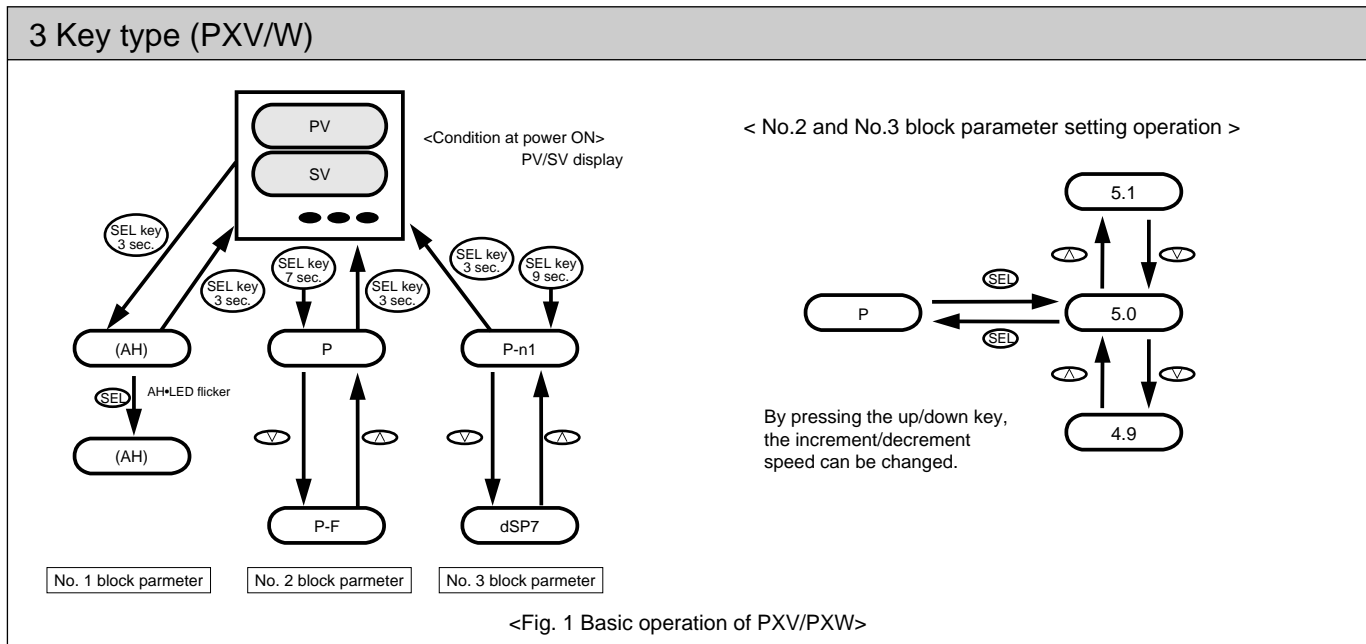

③ Setting of numerical value

▲ key: Numerical value increases by 1 at each press of key.

It keeps increasing by pressing continuously.

▼ key: Numerical value decreases by 1 at each press of key.

It keeps decreasing by pressing continuously.

④ Registration of set data

Automatically registered 3 seconds after data is set.

2-3 Parameter functions and setting method

Setting of set value (SV)

[Description]

- Set values are control target values.
- Upper/lower limit of set value is designated by No. 2 block parameter P-SU/P-SL. P-SL (lower limit) or P-SU (upper limit) cannot be used for setting outside the range (See page 22).
- When a temperature sensor is used for input, the unit of set value is °C or °F. Selection between °C and °F is made by No. 2 block parameter P-F.

Related parameter: P-SL (Page 22)
 P-SU (Page 22)
 LOC (Page 11)

Example) Altering SV 250°C to 1195°C

Key operation	Description	Display
<div style="display: flex; justify-content: space-around;"> <div style="text-align: center;"> <p>For PXV4</p> <p>↓</p> <p>(SEL)</p> <p>↓</p> <p>(^) (v)</p> <p>↓</p> <p>(END)</p> <p>↓</p> <p>(SEL)</p> </div> <div style="text-align: center;"> <p>For PXW</p> <p>↓</p> <p>(^) (v)</p> <p>↓</p> <p>(END)</p> <p>↓</p> <p>(SEL)</p> </div> </div>	<p>Press SEL key once, then SV display lamp is lighted, and current value is displayed.</p> <p>Press the (^) or (v) key to display 1195.</p> <p>SV is automatically registered in 3 second.</p> <p>Press the SEL key to return to the operating status display. Also, after 30 seconds without key operation, data is automatically returned to the operating status display.</p>	<p>PV SV 250</p> <p>1195</p> <p>1195</p>





Upper limit alarm (ALM1) setting (option) (Setting is possible within input range)

[Description]

- Alarm is not displayed without upper limit alarm function.
- When using upper limit alarm, it is necessary to set alarm type (see parameter P-AH) and appropriate code.
- When input or deviation is larger than AH, the alarm output turns ON (see diagram (a) below).
- When it is the range alarm and input or deviation is larger than AH, the alarm output turns ON (see diagram (b) below).
- Selection between absolute value alarm and deviation alarm is made by P-An.
- Alarm action hysteresis can be set by No. 2 block parameter P-An.

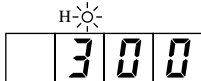
Related parameter: P-AH (Page 24)
P-AL (Page 24)
P-An (Page 32)

Example) Altering the upper limit alarm of 300°C to 550°C

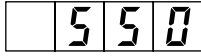
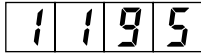
Key operation	Description	Display
SEL	Hold down SEL key for 3 seconds. Current upper limit value (300°) is displayed, and H indication lamp blinks.	
 	Press the  or  key to display 550.	
(END)	The upper limit alarm value is automatically registered in 3 seconds. Operation is started with 550° of upper limit alarm.	
SEL	Hold down the key for 3 seconds to display the main set value.	

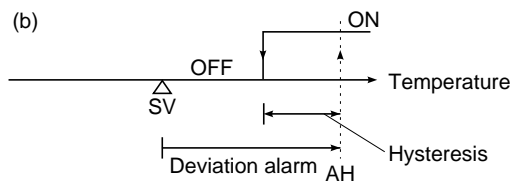
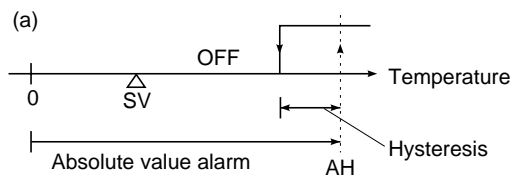

Lower limit alarm (ALM2) setting (option) (Setting is possible within input range)

[Description]

- Alarm is not displayed without lower limit alarm function.
- When input or deviation is smaller than AL, or when deviation is larger than AL, alarm output turns ON.
- When using lower limit alarm, it is necessary to set alarm type (see parameter P-AL) and appropriate code.
- When lower limit alarm with hold function is used, lower limit alarm does not turn ON even it the input is smaller than AL (see diagram (c) below).
- When it is the range alarm and input or deviation is smaller than AL, the alarm output turns OFF (see diagram (b) below).
- Selection between absolute value alarm and deviation alarm is made by P-AL.
- Alarm action hysteresis can be set by No. 2 block parameter P-An.

Related parameter: P-AH (Page 24)
P-AL (Page 24)
P-An (Page 32)

Example) Altering the lower limit alarm of 200°C to 100°C

Key operation	Description	Display
	Hold down the key for 3 second. H indication lamp is lighted.	
	Press the SEL key once. Current lower limit alarm value (200°) is displayed. L indication lamp blinks.	
	Press the or key to display 100.	
	After 3 seconds the lower limit alarm value is automatically registered. Operation is started with 100°C of lower limit alarm.	
	Hold down the key for 3 seconds to display operating status display.	

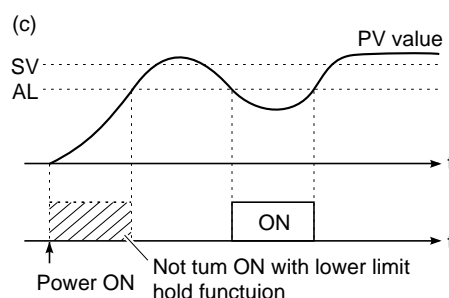
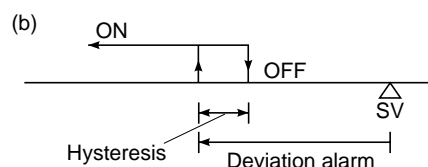
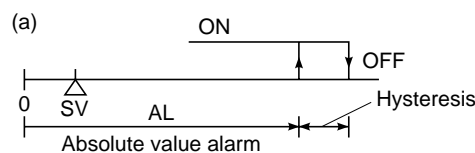

Heater burnout alarm (option) (Setting range: 1.0 to 50.0A)

[Description]

- Burnout detect current (parameter Hb) should be set according to the type of heater being used. It is set to 0.0 prior to delivery from the factory.
- Alarm operating point is set by parameter Hb.
- Current detector (CT) comes in 2 types, 0 to 30A type (CTL-6-SF) and 20 to 50A type (CTL-12-S36-8F). It should be selected according to the heater power source being used.
- Setting of alarm operating point
 - Apply current to the heater with the controller output turned ON.
 - Search alarm operating value while changing the set value of Hb) when changing the set value, the next set value should be changed more than 3 seconds later).
 - After operating point is obtained, use 70 to 80% of the value as the final set value.
 - When N number of heaters are used, set it in the middle between the current at N number of heaters and that of N-1 number.

- The heater burnout alarm function can not be used in case when the heater is controlled by thyristor phase angle control system.
- When 3-phase heater is used, heater burnout can be detected in some cases. For details, contact our office.
- Connect of heater burnout detect CT

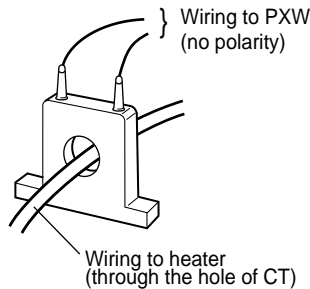

- When detection error is large due to small heater capacity, increase the apparent current 2 times larger by putting the wire twice through the hole to improve the sensitivity of the detector (in this case, set the current to a two-fold value).
- When wire through CT is wound many turns, be sure to wind it from the same direction.

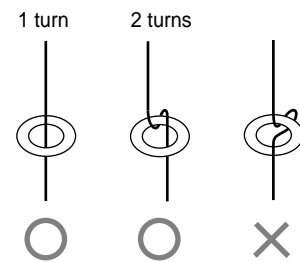

(Note) In using heater burnout alarm, set the proportional cycle (TC) to more than 20 seconds.

Related parameter: TC (Page 15)

- Example of connection of heater burnout alarm (Type: PXW5, PXW9)

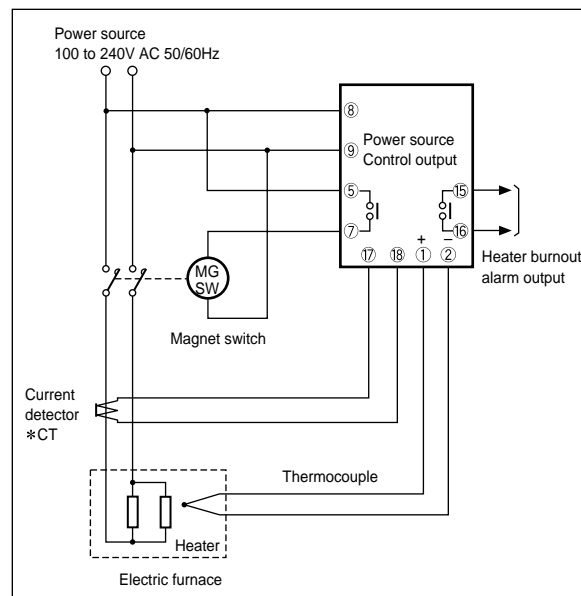

Example) Altering alarm setpoint of heater burnout current of 9.0A to 8.0A

Key operation	Description	Display
SEL	Hold down the key for 3 seconds, then H indication lamp blinks.	
SEL	Press the key once. L indication lamp blinks.	
SEL	Press the SEL key once. Current data of 9.0A is displayed. HB indication lamp blinks.	
▲ ▼	Press the ▲ or ▼ key to display 8.0.	
(END)	After 3 seconds, data of 8.0A is automatically registered. Operation is started with data of 8.0A.	
SEL	Hold down the key for 3 seconds to display the operation status.	

A 7

Auto-tuning (Setting range: 0, 1, 2)

[Description]

- PID value can be set automatically.
- Once PID value is set automatically by auto-tuning, it is saved in the controller even when the power is turned OFF, so auto-tuning function is not required any further.
- Auto-tuning is started by setting 1 or 2 in AT parameter. AT value is automatically reset to 0 at the end of auto-tuning.
- AT the end of auto-tuning, control action is started automatically by setting PID.
- During auto-tuning, the decimal point at 1 digit of SV display flickers.
- When auto-tuning is forcibly suspended, set AT value to 0 or turn OFF the instrument power.
- AT is available in the following 2 types.

Setting code	Method
1	SV type SV ON-OFF action
2	Low PV type SV-10%FS ON-OFF action

During auto-tuning, ON-OFF control is performed which causes overshoot for SV. But, the overshoot can be eliminated by low PV type auto-tuning.

- Auto-tuning is available just after the start of operation or in the state of stable control.
- When dual output type is used, auto-tuning is effected only on the heating control side. At this time, the cooling side output is OFF. The cooling side proportional band can be set manually by the parameter COOL.

Example) Starting auto-tuning

Key operation	Description	Display
SEL	Hold down the key for 3 seconds. H indication lamp blinks.	<div style="display: flex; justify-content: space-around; align-items: center;"> H-☉ <div style="border: 1px solid black; padding: 2px;">300</div> </div>
SEL	Press the key once. L indication lamp blinks.	<div style="display: flex; justify-content: space-around; align-items: center;"> L-☉ <div style="border: 1px solid black; padding: 2px;">200</div> </div>
SEL	Press the key once. HB indication lamp blinks.	<div style="display: flex; justify-content: space-around; align-items: center;"> HB-☉ <div style="border: 1px solid black; padding: 2px;">80</div> </div>
SEL	Press the key once. "Auto tuning release (AT0)" is displayed.	<div style="border: 1px solid black; padding: 2px; display: inline-block;">A T 0</div>
△	Press the key once. Change 0 to 1. (1: with auto-tuning)	<div style="border: 1px solid black; padding: 2px; display: inline-block;">A T 1</div>
(Start)	After 3 seconds, auto-tuning will be started automatically.	<div style="border: 1px solid black; padding: 2px; display: inline-block;">A T 1</div>
(In auto-tuning)	Decimal point in 1st digit blinks.	<div style="border: 1px solid black; padding: 2px; display: inline-block;">A T . 1</div>
(Auto-tuning ends)	Auto-tuning is now completed. (SV is displayed automatically 30 seconds after auto-tuning is started.)	<div style="border: 1px solid black; padding: 2px; display: inline-block;">A T 1</div>
SEL	Hold down the key for 3 seconds to display the operation status.	<div style="border: 1px solid black; padding: 2px; display: inline-block;">1195</div>

Blinking disappears.

Related parameter: P (Page 12)
I (Page 13)
D (Page 14)

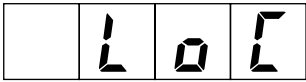

Key lock (Setting range: 0, 1, 2)

[Description]

- Key lock is a function not to change set data accidentally. Parameters SV and data can be displayed.
- When key lock is released again, change the setting to release the key to "0".

(Note) Key lock comes in 2 types, one is used to prevent change of all setting (setting = 1) and another is used to prevent change of values other than SV (setting = 2).

Setting code 0: No lock

Setting code 1: Lock of all settings

Setting code 2: Lock of values other than SV

Example) Key lock to prevent accidental data change

Key operation	Description	Display
(SEL)	Hold down the key for 3 seconds. H indication lamp blinks.	
↓ (SEL)	Press the SEL key repeatedly until L o L is displayed. Current data (0: no key lock) is displayed.	
↓ (^)	Press the key once. Change 0 to 1.	
↓ (END)	After 3 seconds, data will be key-locked automatically.	
↓ (SEL)	Hold down for 3 seconds to display the operation status. To release key lock, reset L o L setting to 0 (no key lock).	



Setting of proportional band (Setting range: 0 to 999.9% for input range)

[Description]

- Proportional band can be set automatically by auto-tuning.
- Manual setting is also possible. If P value is too small, control action becomes unstable, and if it is too large, the response becomes slow.
- When P is set to 0.0, 2-position action becomes effective.
The hysteresis under 2-position action should be set with the parameter HYS.
- When dual output type is used and it is set to P = 0.0 and COOL = 0.0, the heating and cooling outputs are as shown in the following diagram. In this case, the hysteresis is fixed at 0.5%.

Related parameter: HYS (Page 16)

Example) Altering proportional band 10.0% to 15.0%

Key operation	Description	Display
(SEL)	Hold down the key for 7 seconds, and P is displayed.	<input type="text" value=""/> <input type="text" value=""/> <input type="text" value=""/> <input type="text" value="P"/>
(SEL)	Press the SEL key once. Current proportional band (10.0%) is displayed.	<input type="text" value=""/> <input type="text" value="1"/> <input type="text" value="0"/> <input type="text" value="0"/>
(^) (v)	Press the (^) or (v) key to display 15.0.	<input type="text" value=""/> <input type="text" value="1"/> <input type="text" value="5"/> <input type="text" value="0"/>
(END)	After 3 seconds, proportional band will be registered automatically. Operation is started with 15.0% proportional band.	
(SEL)	Hold down the key for 3 seconds to display the operation status.	<input type="text" value="1"/> <input type="text" value="1"/> <input type="text" value="9"/> <input type="text" value="5"/>

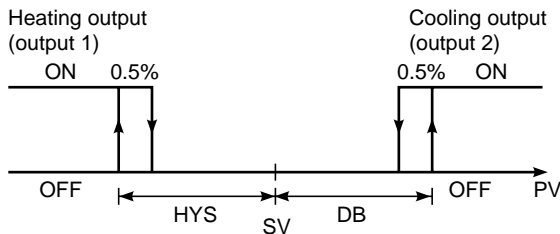



Integral time (Setting range: 0 to 3200 sec.)

[Description]

- Integral time can be set automatically by auto-tuning.
- Manual setting is also possible.
- When I value is set to 0, integral action becomes OFF and P action is effected.

Example) Altering the integrating time of 600 seconds to 840 seconds

Key operation	Description	Display
SEL	Hold down the key for 7 seconds, and P is displayed.	
∇	Press the key once.	
SEL	Press the SEL key once. Current integrating time (600 seconds) is displayed.	
△ ∇	Press the △ or ∇ key to display 840.	
(END)	After 3 seconds, the integrating time will be registered automatically. Operation is started with an integrating time of 840 seconds.	
SEL	Hold down the key for 3 seconds to display the operation status.	



Derivative time (Setting range: 0.0 to 999.9 seconds)

[Description]

- Derivative time can be set automatically by auto-tuning.
- Manual setting is also possible.
- When D value is set to 0, derivative action becomes OFF and PI action is effected.

Example) Altering a derivative time of 120.0 seconds to 100.0 seconds

Key operation	Description	Display
SEL	Hold down the key for 7 seconds, and P is displayed.	<input type="text" value=""/> <input type="text" value=""/> <input type="text" value=""/> <input type="text" value="P"/>
↓ V	Press the key repeatedly until d is displayed.	<input type="text" value=""/> <input type="text" value=""/> <input type="text" value=""/> <input type="text" value="d"/>
SEL	Press the key once. Current derivative time (120.0 seconds) is displayed.	<input type="text" value="1"/> <input type="text" value="2"/> <input type="text" value="0"/> <input type="text" value="."/> <input type="text" value="0"/>
↑ ↓	Press the <input type="text" value="↑"/> or <input type="text" value="↓"/> key to display 100.0.	<input type="text" value="1"/> <input type="text" value="0"/> <input type="text" value="0"/> <input type="text" value="."/> <input type="text" value="0"/>
(END)	After 3 seconds, the derivative time will be registered automatically. Operation is started with 100.0 seconds of derivative time.	
SEL	Hold down the key 3 seconds to display the operation status.	<input type="text" value="1"/> <input type="text" value="1"/> <input type="text" value="9"/> <input type="text" value="5"/>



Setting of proportional cycle of control output 1 (Setting range 1 to 150 sec.)

[Description]

- When contact output or SSR drive output type is used, the output turns ON/OFF at a contact cycle when the input is within the proportional band.

This cycle is called the proportional cycle. The output value is expressed by the ratio which the output turns ON within the time of proportional cycle.

As the time of proportional cycle becomes short, control can be made more accurately, but it reduces the life of operation terminal unit, so it needs to be set in consideration of the life of operation terminal unit. In this case of current output, this parameter is not displayed.

The following shows the standard proportional cycle.

SSR, SSC:

Proportional cycle, 1 to 2 sec.

Contact output:

Proportional cycle, 20 to 30 sec.

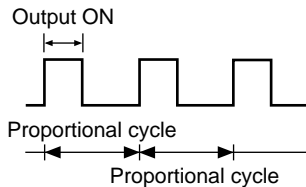

Example) Altering a proportional cycle of 30 seconds to 20 seconds

Key operation	Description	Display
(SEL)	Hold down the key for 7 seconds, and P is displayed.	
(V)	Press the key repeatedly until 7L is displayed.	
(SEL)	Press the key once. Current proportional cycle (30 seconds) is displayed.	
(^) (V)	Press the (^) or (V) key to display 20.	
(END)	After 3 seconds, the proportional cycle will be registered. Operation is started with 20 seconds of proportional cycle.	
(SEL)	Hold down the key for 3 seconds to display the operation status.	

□ □ **H 4 5** □ □

2-position action hysteresis width (Setting range: 0.0 to 50.0%FS)

[Description]

- Hysteresis width under the 2-position action control can be set as shown in the example. When hysteresis width is set small, the control efficiency is improved, but the number of operations increases and decreases the life of the operation terminal unit and the device.
- Hysteresis width is necessary to prevent chattering due to noise.
- For 2-position action, the value of P (proportional band) should be set to 0.0.
- Set value can be obtained by industrial value.

Related parameter: P (Page 6)

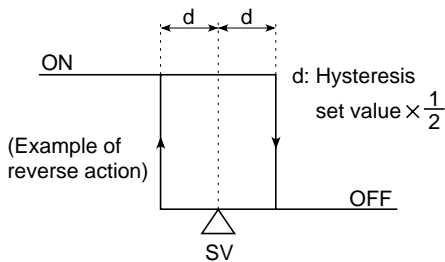

Example) Altering the hysteresis width of 1°C to 2°C

Key operation	Description	Display
	Hold down the key for 7 seconds, and P is displayed.	□ □ □ P
	Press the key repeatedly until H 4 5 is displayed.	□ H 4 5 □ □
	Press the key once. Current data of 1°C is displayed.	□ □ □ 1
	Press the or key to display 2.	□ □ □ 2
	After 3 seconds, data of 2°C will be registered. Operation is started with 2°C of data.	
	Hold down the key for 3 seconds to display the operation status.	1 1 9 5

7 0 2

Cooling side proportional cycle of control output 2 (DUAL type only) (Setting range: 1 to 150 sec.)

[Description]

- This setting is required only for DUAL type.
- When contact output or SSR drive output type is used, the output turns ON/OFF at a constant cycle when the input is within the proportional band. This cycle is called the proportional cycle. The output value is expressed by the ratio of which the output turns ON within the time of proportional cycle. As the time of proportional cycle becomes short, control can be made more accurately, but it reduces the life of operation terminal unit, so it needs to be set in consideration of the life of operation terminal unit.
- In the case of current output, this parameter is not displayed.

The following shows the standard proportional cycles.

SSR, SSC:

Proportional cycle, 1 to 2 sec.

Contact output:

Proportional cycle, 20 to 30 sec.

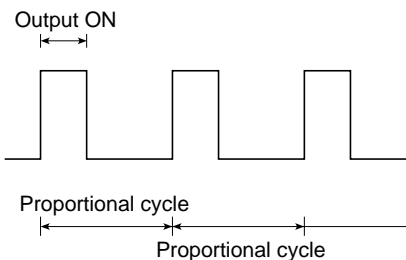

Example) Altering cooling control proportional cycle of 30 second to 20 seconds

Key operation	Description	Display
(SEL)	Hold down the key for 7 seconds, and P is displayed.	<input type="text" value=""/> <input type="text" value=""/> <input type="text" value=""/> <input type="text" value="P"/>
(V)	Press the key repeatedly until 7 0 2 is displayed.	<input type="text" value=""/> <input type="text" value="7"/> <input type="text" value="0"/> <input type="text" value="2"/>
(SEL)	Press the key once. Current data (30 seconds) is displayed.	<input type="text" value=""/> <input type="text" value=""/> <input type="text" value="3"/> <input type="text" value="0"/>
(^) (V)	Press the (^) or (V) key to display 20.	<input type="text" value=""/> <input type="text" value=""/> <input type="text" value="2"/> <input type="text" value="0"/>
(END)	After 3 seconds, 20 seconds will be registered. Operation is started in 20 seconds.	
(SEL)	Hold down the key for 3 seconds to display the operation status.	<input type="text" value="1"/> <input type="text" value="1"/> <input type="text" value="9"/> <input type="text" value="5"/>

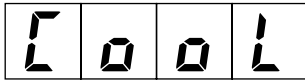

Cooling side proportional band coefficient (DUAL type only) (Setting range: 0, 0.1 to 100.0)

[Description]

- Cooling side proportional band can be set (see diagram (a) below).
- To set cooling side proportional band, its coefficient should be obtained to optimum control from the following equation after setting heating side proportional band.

• Heating side proportional band is Proportional band (P)

$\frac{2}{}$

- Set the coefficient to 0, and the cooling side is put in ON-OFF action.

- Select the item of the setting method parameter display symbol "Cool" of cooling side proportional band coefficient, and the coefficient can be set.

$$\text{Cooling side proportional band} = \frac{\text{Proportional band (P)}}{2} \times \text{Coefficient}$$

Example) Set cooling side proportional band to 10% of full scale by proportional band (P) = 50%

$$10\% = \frac{50\%}{2} \times \text{Coefficient}$$

Therefore, Coefficient = 0.4

(a)

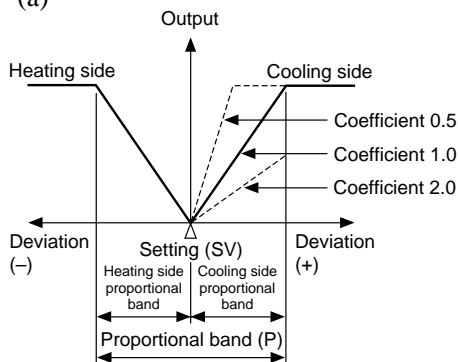

Example) Altering cooling control proportional band coefficient of 5.0 to 5.5

Key operation	Description	Display
	Hold down the key for 7 seconds, and P is displayed.	
	Press the key repeatedly until is displayed.	
	Press the key once. Current data (5.0 coefficient) is displayed.	
	Press the or key to display 5.5.	
	After 3 seconds, 5.5 will be registered automatically. Operation will be started with 5.5 coefficient.	
	Hold down the key for 3 seconds to display the operation status.	

Related parameter: P (Page 12)



Shift of cooling side proportional band (dead band/overlap band) (DUAL type only) (Setting range: -50.0 to +50.0%)

[Description]

- Cooling side proportional band can be shifted for set value (SV) (see diagram (a) below).
- When the value of db is positive, it is called the dead band, and when the value is negative, it is called the overlap band.
- The value of db is set in MV (%). When it is set in deviation (%), it can be converted from the following equation and set.

$$DB (\%) = \text{Deviation} \times \frac{100}{P} (\%)$$

Example) When proportional band (P) = 5.0% and dead band for SV is set at deviation 1.0 (%), the following equation is used for setting this parameter to 20%.

$$DB (\%) = 1.0 \times \frac{100}{5.0} = 20 (\%)$$

Related parameter: P (Page 12)

(a)

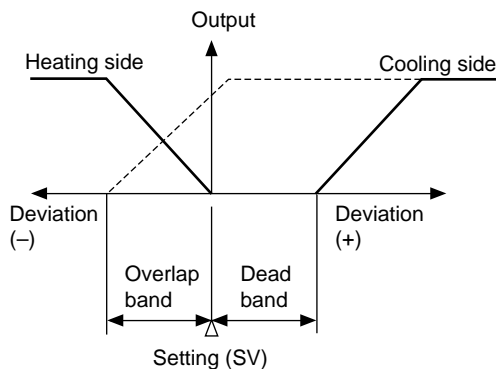

Example) Altering dead band/overlap band of 0% to 1.0% (dead band)

Key operation	Description	Display
	Hold down the key for 7 seconds, and P is displayed.	
	Press the key repeatedly until <i>db</i> is displayed.	
	Press the key once. Current data (0%) is displayed.	
	Press the or key to display 1.0.	
	After 3 seconds, 1.0% will be registered. Operation will be started with 1.0%.	
	Hold down the key for 3 seconds to display the operation status.	

	b	A	L
--	---	---	---

Output convergence value (Setting range: -100.0 to 100.0%)

		A	r
--	--	---	---

**Anti-reset wind up (Setting range: 0 to 100%FS)
(No display prior to delivery)**

[Description]

- This setting is not required unless it is necessary.
This function is used to suppress over-shoot.
- Anti-reset wind up (Ar) is automatically set in optimum value by auto-tuning.
The value of over-shoot can be controlled by setting BAL.
- By setting anti-reset wind up (Ar) in optimum value, unwanted integral action can be cut and over-shoot is reduced.

(Note) This controller has fuzzy control function, so over-shoot can be minimized without using BAL and Ar. This parameter is used only for interchangeability with former type (PYZ series).

Example) Altering anti-reset wind up of 80°C to 60°C

Key operation	Description	Display				
(SEL)	Hold down the key for 7 seconds, and P is displayed.	<table border="1"><tr><td></td><td></td><td></td><td>P</td></tr></table>				P
			P			
(V)	Press the key repeatedly until Ar is displayed.	<table border="1"><tr><td></td><td></td><td>A</td><td>r</td></tr></table>			A	r
		A	r			
(SEL)	Press the key once. Current data (80°C) of anti-reset wind up is displayed.	<table border="1"><tr><td></td><td></td><td>8</td><td>0</td></tr></table>			8	0
		8	0			
(^) (v)	Press the (^) or (v) key to display 60.	<table border="1"><tr><td></td><td></td><td>6</td><td>0</td></tr></table>			6	0
		6	0			
(END)	After 3 seconds, anti-reset wind up will be registered.					
(SEL)	Hold down the key for 3 seconds to display the operation status.	<table border="1"><tr><td>1</td><td>1</td><td>9</td><td>5</td></tr></table>	1	1	9	5
1	1	9	5			

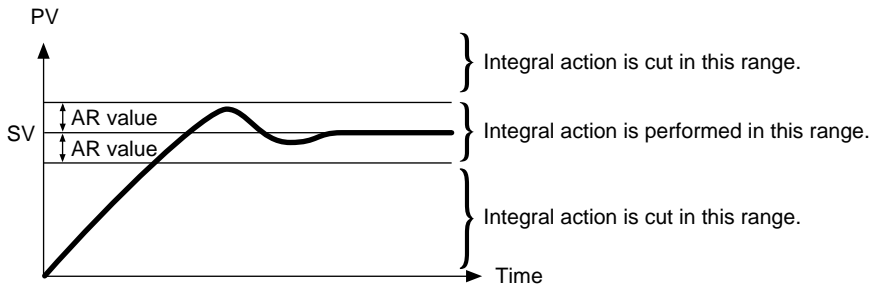

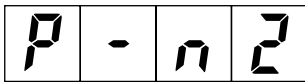

Setting of input type

[Description]

- Input type can be set.
- The main unit is determined according to input type (2 types shown below). Set a code that conforms with the main unit.
- Input type can be changed within the same types. It cannot be changed to different types.

Type I: Thermocouple (9 types).
Resistance bulb (1 type)

Type II: Voltage, current

- On the Type II, when selecting voltage input or current input, it becomes necessary to change the code and connect a resistor 250Ω to the input terminal when current input is used.
- When changing the voltage input, remove the resistor 250Ω from the input terminal.

Change of software
After changing software, turn OFF the power and then turn ON once again.

- Input type and code
- ① Input type code table

Type	Code (P-n2)
Resistance bulb	
• Pt 100	1
Thermocouple	
• J	2
• K	3
• R	4
• B	5
• S	6
• T	7
• E	8
• N	12
• PL-II	13
1 to 5V DC, 4 to 20mA DC	16

Example) Altering thermocouple from K to T on Type I

Key operation	Description	Display
(SEL)	Hold down the key for 7 seconds, and P is displayed.	□ □ □ P
↓ (V)	Press the key repeatedly until P-n2 is displayed.	P - n 2
↓ (SEL)	"3" is displayed, and it is clear thermocouple K is selected.	□ □ □ 3
↓ (^) (V)	Press the (^) or (V) key to display 7.	□ □ □ 7
↓ (END)	After 3 seconds, data will be registered automatically.	
↓ (SEL)	Hold down the key for 3 seconds to display the operation status.	1 1 9 5

Related parameter: P-SL (Page 22)
P-SU (Page 22)
P-dP (Page 23)

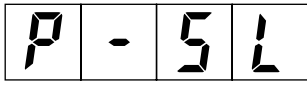

Lower limit of measurement range and set value (SV)
 (Setting range: -1999 to 9999)

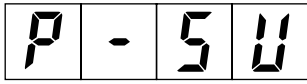

Upper limit of measurement range and set value (SV)
 (Setting range: -1999 to 9999)

[Description]

- Lower limit (minimum range) and upper limit (maximum range) of measurement ranges can be set. This setting is used as a limiter of set value (SV). Change of set value (SV) to others outside of the lower/upper limit range is not possible.
- When 1 digit below the decimal point needs to be displayed, it should be set to 1 by P-dP.
- When P-n2 is set to 0 to 13 (temperature input), up to 1 digit (P-dP parameter = 1) below the decimal point becomes effective.
- For the input range, refer to the following table.

Related parameter: P-dP (Page 23)

② Input range table (standard range)

		Measurement range (°C)	Measurement range (°F)	With decimal point (°C)	With decimal point (°F)
Resistance bulb JIS (IEC)	Pt100Ω	0 to 150	32 to 302	○	○
	Pt100Ω	0 to 300	32 to 572	○	○
	Pt100Ω	0 to 500	32 to 932	○	○
	Pt100Ω	0 to 600	32 to 1112	○	×
	Pt100Ω	-50 to 100	-58 to 212	○	○
	Pt100Ω	-100 to 200	-148 to 392	○	○
	Pt100Ω	-150 to 600	-238 to 1112	○	×
	Pt100Ω	-150 to 850	-238 to 1562	×	×
Thermocouple	J	0 to 400	32 to 752	○	○
	J	0 to 800	32 to 1472	○	×
	K	0 to 400	32 to 752	○	○
	K	0 to 800	32 to 1472	○	×
	K	0 to 1200	32 to 2192	×	×
	R	0 to 1600	32 to 2912	×	×
	B	0 to 1800	32 to 3272	×	×
	S	0 to 1600	32 to 2912	×	×
	T	-199 to 200	-328 to 392	○	×
	T	-150 to 400	-238 to 752	○	×
	E	0 to 800	32 to 1472	○	×
	E	-199 to 800	-328 to 1472	○	×
	N	0 to 1300	-32 to 2377	×	×
PL-11	0 to 1300	32 to 2372	×	×	
Direct current voltage	1 to 5V DC 4 to 20mA DC	-1999 to 1999 (Sealing possible)			

Example) Altering the measuring range of 0 ~ 150°C to -100~200°C (Pt100)

Key operation	Description	Display
(SEL)	Hold down the key for 7 seconds, and P is displayed.	
(V)	Press the key repeatedly until P-SL is displayed.	
(SEL)	Current measuring range is displayed.	
(Δ) (▽)	Press the key to display -100. Data is registered.	
(SEL)	The following parameter P-SU is displayed.	
(V)	Current measuring range is displayed.	
(SEL)	Press the (Δ) or (▽) key to display 200.	
(Δ) (▽)	After 3 seconds, data will be registered automatically. Hold down the key for 3 seconds to display the operation status.	
(END)		

* For 4 to 20mA DC input, connect external resistor 250Ω and use as 1 to 5V DC input.

Note) Input accuracy is ±0.5%FS±1digit with the exception of the following
 R thermocouple, 0 to 400°C : ±1%FS±1digit±1°C
 R thermocouple, 0 to 500°C : ±5%FS±1digit±1°C
 Other thermocouples : ±0.5%FS±1digit±1°C

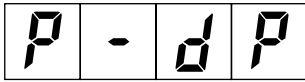

Setting of decimal point position (Setting range: 0 to 2)

[Description]

- Decimal point position can be set on LED display.

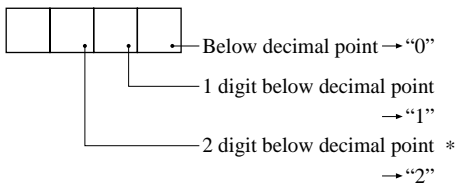

* "2" becomes invalid for an input except for current/voltage.

Related parameter: P-SL (Page 22)
P-SU (Page 22)

Example) Altering the measuring range 0~150°C to 0.0 ~150°C

Key operation	Description	Display
(SEL)	Hold down the key for 7 seconds, and P is displayed.	
(V)	Press the key repeatedly until P-dP is displayed.	
(SEL)	"0" is displayed and it is clear that none below decimal point is set.	
(^)	Press the key once to display 1.	
(END)	After 3 seconds, data will be registered automatically.	
(SEL)	Hold down the key for 3 seconds to display the operation status.	

P - AL

Setting of lower limit alarm (ALM2) action type (option)

P - AH

Setting of upper limit alarm (ALM1) action type (option)

[Description]

Alarm action can be selected from 16 types. Of these types, deviation alarm, absolute value alarm, range alarm and hold (lower limit) are explained in the following. Alarm is specified by either one of deviation and absolute value.

Deviation alarm

When alarm is outputted at temperature of more than 100°C above 100°C of set value (SV) and more than 50°C below the set value, the setting of upper limit alarm (AH) is 100°C and that of lower limit alarm (AL) is 50°C. When the set value (SV) changes, the alarm action point is also changed.

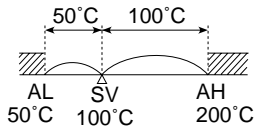

Absolute value alarm

When alarm is outputted at temperature of more than 200°C and less than 50°C the setting of upper limit alarm (AH) is 200°C and that of lower limit alarm (AL) is 50°C. Unlike the deviation alarm, the alarm action point remains unchanged at change of the set value.

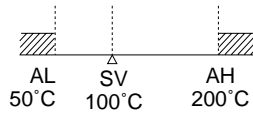

Range alarm

In the case of range alarm, either one of absolute value and deviation can be selected. Alarm is outputted between AL and AH.

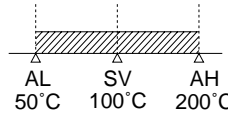

Lower limit hold

At the start of operation, the furnace temperature is normally below 100°C. In this case, lower limit alarm is not outputted. When temperature rises above the set value of AL and then lowers, lower limit alarm turns ON. This function is called the alarm action "Hold".

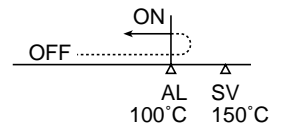

Alarm action type code table

	ALM1 (P-AH)	ALM2 (P-AL)	Alarm type	Action diagram		ALM1 (P-AH)	ALM2 (P-AL)	Alarm type	Action diagram
	0	0	Without alarm			11	11	Range upper/lower limit deviation (ALM1/2 independent action)	
Absolute value alarm	1	1	Upper limit absolute		Range alarm	-	12	Range upper/lower limit absolute	
	2	2	Lower limit absolute			-	13	Range upper/lower limit deviation	
	3	3	Upper limit absolute (with hold)			-	14	Range upper limit absolute and lower limit deviation	
	4	4	Lower limit absolute (with hold)			-	15	Range upper limit deviation and lower limit absolute	
Deviation alarm	5	5	Upper limit deviation			Note) Alarm set value may change with change in alarm action type.			
	6	6	Lower limit deviation						
	7	7	Upper/lower limit deviation						
	8	8	Upper limit deviation (with hold)						
	9	9	Lower limit deviation (with hold)						
	10	10	Upper/lower limit deviation (with hold)						

Related parameter: AL (Page 6)
 AH (Page 7)
 P-An (Page 32)

Example) Altering upper limit alarm (ALM1) action from upper limit deviation alarm to upper limit absolute value alarm

Key operation	Description	Display
SEL	Hold down the key for 7 seconds, and P is displayed.	□ □ □ P
↓ V	Press the key repeatedly until P-AH is displayed.	P - A H
↓ SEL	Press the SEL key. Data is displayed. Display 5 due to deviation alarm.	□ □ □ 5
↓	Check that 5 is displayed and change the alarm to absolute value alarm 1.	
↓ ^ V	Press the ^ or V key to display 1.	□ □ □ 1
↓ (END)	After 3 seconds, data will be registered automatically.	
↓ SEL	Hold down the key for 3 seconds to display the operation status.	1 1 9 5

Upper limit alarm (ALM1) and lower limit alarm (ALM2) are the same key operation with the exception of range alarm action. Upper limit alarm (ALM1) can be used low-low limit alarm by setting is as lower limit alarm or lower limit alarm (ALM2) as upper-upper alarm by setting is as upper limit alarm.



PV offset (Setting range: -10 to 10%FS)

[Description]

- Set value is added to designated input value. It is mainly used when recorder needs to conform with the designated value.
- Control is performed by the displayed PV value (PV offset is added).

Example) Set the zero shift width of 5°C to input value 1200°C

Key operation	Description	Display
SEL	Hold down the key for 7 seconds, and P is displayed.	<input type="text"/> <input type="text"/> <input type="text"/> P
↓ V	Press the key repeatedly until PVOF is displayed.	P U O F
↓ SEL	Press the SEL key. Data is displayed.	<input type="text"/> <input type="text"/> <input type="text"/> 0
↓ ^	Press the key 5 times.	<input type="text"/> <input type="text"/> <input type="text"/> 5
↓ (END)	After 3 seconds, data will be registered automatically.	
↓ SEL	Hold down the key for 3 seconds to display the operation status.	1 1 9 5

S U O F

SV offset (Setting range: -50 to 50%FS)

[Description]

- The value set in SV offset is added to original SV to perform control by SV value. It is mainly used to eliminate offset during P control. In this case, designated SV value remains unchanged.

Example) Set the zero shift width of 9°C to current setting value.

Key operation	Description	Display
(SEL)	Hold down the key for 7 seconds, and P is displayed.	<input type="text"/> <input type="text"/> <input type="text"/> P
↓ (V)	Press the key repeatedly until SVOF is displayed.	S U O F
↓ (SEL)	Press the SEL key. Data is displayed.	<input type="text"/> <input type="text"/> <input type="text"/> 0
↓ (^) (v)	Press the (^) or (v) key to display 9.	<input type="text"/> <input type="text"/> <input type="text"/> 9
↓ (END)	After 3 seconds, data will be registered automatically.	
↓ (SEL)	Hold down the key for 3 seconds to display the operation status.	1 1 9 5

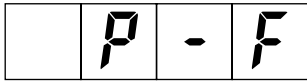

Selection of measurement input °C/°F

[Description]

- The unit (°C or °F) of temperature can be selected for temperature input. It has been set according to the ordering specifications prior to delivery from factory. If it becomes necessary to change it after purchase, the input range (P-SL, P-SU), alarm value (AL, AH), set value (SV) and offset (PVOF, SVOF) should be changed.

The unit of temperature is shown on the front nameplate. It should also be changed at the same time.

(Note 1)

$$T_1 (°F) = \frac{9}{5} T_2 (°C) + 32$$

Related parameter: SV (Page 5)
 P-SL (Page 22)
 P-SU (Page 22)
 AL (Page 6)
 AH (Page 7)

Example) Altering the unit of measurement input from °C to °F

Key operation	Description	Display
SEL	Hold down the key for 7 seconds, and P is displayed.	
↓ V	Press the key repeatedly until P-F is displayed.	
↓ SEL	Press the SEL key. Data is displayed.	
↓ ^	Press the key once to display "°F".	
↓ (END)	After 3 seconds, data will be automatically registered.	
↓ SEL	Hold down the key for 3 seconds to display the operation status.	

5 F A F

Program status display (display only)

5 0 - 1 ~ 5 0 - 4

No. 1 to 4 target value

r n 1 r ~ r n 4 r

No. 1 to 4 ramp time

r n 1 5 ~ r n 4 5

No. 1 to 4 soak time

[Description]

- This is a function to change set value (SV) with time automatically according to preset pattern. Up to 4 ramp/soak data can be programmed.
- No. 1 ramp starts from measurement value (PV) just before the program is executed.
- It is also possible to run the program automatically at power ON (power ON start function).

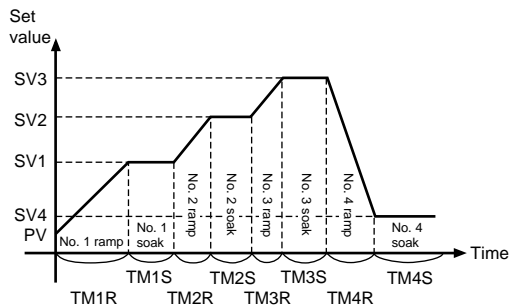

Example) Set No. 1 target value to 400°C

Key operation	Description	Display
(SEL)	Hold down the key for 7 seconds, and P is displayed.	<input type="text" value=""/> <input type="text" value=""/> <input type="text" value=""/> <input type="text" value="P"/>
(V)	Press the key repeatedly until SV-1 is displayed.	<input type="text" value="5"/> <input type="text" value="0"/> <input type="text" value="-"/> <input type="text" value="1"/>
(SEL)	Press the SEL key to display data.	<input type="text" value=""/> <input type="text" value=""/> <input type="text" value=""/> <input type="text" value="0"/>
(Δ) (V)	Press the (Δ) or (V) key to display 400°C.	<input type="text" value=""/> <input type="text" value="4"/> <input type="text" value="0"/> <input type="text" value="0"/>
(END)	After 3 seconds, data will be automatically registered.	
(SEL)	Hold down the key for 3 seconds to display the operation status.	<input type="text" value="1"/> <input type="text" value="1"/> <input type="text" value="9"/> <input type="text" value="5"/>

Ramp Time to change in set value toward target value.

Soak Time not to change set value as it is set to target value.

[Parameters]

To execute this function, the program should be set in advance. It can be set by setting the required set value (SV) in the parameters shown in the table at right.

Related parameter: ProG (Page 39)

Parameter display symbol	Name	Description	Initial value at delivery	Remarks
5 F A F	STAT	Actual program position	-	Not displayed when ramp/soak is not given.
5 0 - 1 5 0 - 4	SV-1 SV-4	No. 1 to 4 ramp target value	0%FS	
r n 1 r r n 4 r	TM1r TM4r	No. 1 to 4 ramp time	0.00	
r n 1 5 r n 4 5	TM1s TM4s	No. 1 to 4 soak time	0.00	
n o d	Mod	Ramp SV mode	0	



Setting of control mode

[Description]

- Used to set control mode, normal/reverse action and the direction of burnout.
- Control mode is classified into the standard type (1 output) and the dual output type for heating/cooling control.
- The main body of standard type is different from that of dual output type. Be sure to set a code that conforms to the main unit.

Example) Altering lower burnout/reverse action to upper burnout/normal action

Key operation	Description	Display
(SEL)	Hold down the key for 9 seconds, and P-n1 is displayed. (P is displayed midway, but hold down the key.)	P - n 1
(SEL)	Press the SEL key to display data.	□ □ □ 0
(∧) (∨)	Press the (∧) or (∨) key to display 3.	□ □ □ 3
(END)	After 3 seconds, upper limit burnout/normal action will be registered.	
(SEL)	Hold down the key for 3 seconds to display the operation status.	1 1 9 5

Control action code table

Code (P-n1)	Output type	Control action		Direction of burnout	
		Output 1	Output 2	Output 1	Output 2
0	Single	Reverse action	...	Lower limit	...
1				Upper limit	
2		Normal action		Lower limit	
3				Upper limit	
4	Dual	Reverse action	Normal action	Lower limit	Lower limit
5				Upper limit	Lower limit
6				Lower limit	Upper limit
7				Upper limit	Upper limit
8		Normal action		Lower limit	Lower limit
9				Upper limit	Lower limit
10				Lower limit	Upper limit
11				Upper limit	Upper limit
12		Reverse action	Reverse action	Lower limit	Lower limit
13				Upper limit	Lower limit
14				Lower limit	Upper limit
15				Upper limit	Upper limit
16	Normal action			Lower limit	Lower limit
17				Upper limit	Lower limit
18				Lower limit	Upper limit
19				Upper limit	Upper limit

P - d F

Input filter constant (Setting range: 0.0 to 900.0 sec.)

[Description]

- Input filter function is used to reduce noise contained in input signal. Input filter constant is time constant.

For example, the following response can be obtained by setting the input filter constant to 10 seconds.

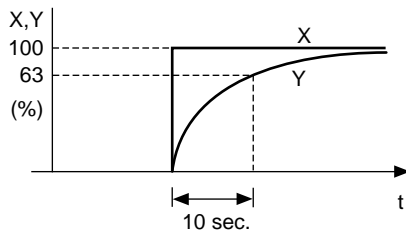
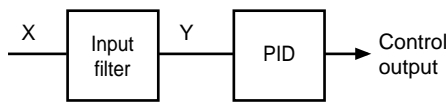

- The set value is the time to read 63% (Y) on the controller for change in PV of 100% (X).

(Note) The unit is set to 5.0 (5 sec.) prior to delivery. Do not change it unless necessary.

Example) Altering filter constant 5.0 (5 seconds) to 10.0 (10 seconds)

Key operation	Description	Display
(SEL)	Hold down the key for 9 seconds, and P-n1 is displayed. (P is displayed midway, but hold it down.)	P - n 1
(V)	Press the key repeatedly until P-dF is displayed.	P - d F
(SEL)	Press the SEL key. Current data is displayed.	5.0
(^) (v)	Press the (^) or (v) key to display 10.0.	10.0
(END)	After 3 seconds, the data will be automatically registered.	
(SEL)	Hold down the key for 3 seconds to display the operation status.	1195

P - A n

Alarm hysteresis width (option) (Setting range: 0 to 50%FS)

[Description]

- Alarm is 2-position action. ON and OFF, while hysteresis is the difference in input ON and OFF. For example, when hysteresis is 5°C, the width of ON and OFF is 5°C. Normally, it is set to 1°C
- Decimal point is given automatically by setting it with P-dP.

(Upper limit alarm)

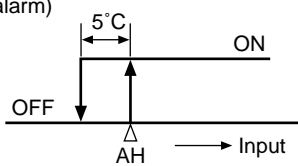

(Lower limit alarm)

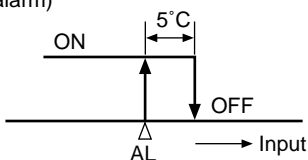

(Range alarm)



Example) Altering alarm hysteresis 1°C to 3°C

Key operation	Description	Display
(SEL)	Hold down the key for 9 seconds, and P-n1 is displayed. (P is displayed midway, but hold it down.)	P - n 1
(V)	Press the key repeatedly until P-An is displayed.	P - A n
(SEL)	Press the SEL key. Current data is displayed.	1
(^) (v)	Press the (^) or (v) key to display 3.	3
(END)	After 3 seconds, the data will be automatically registered.	
(SEL)	Hold down the key for 3 seconds to display the operation status.	1 1 9 5

- Related parameter: AL (Page 6)
 AH (Page 7)
 P-AH (Page 24)
 P-AL (Page 24)

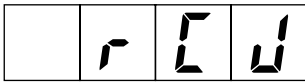

Setting of RCJ compensation

[Description]

- This function is used whether or not RCJ compensation (cold contact compensation) is used for thermocouple input. Normally, it should be used at ON (RCJ compensation) which has been set prior to delivery from the factory.
- It should be set to OFF only when cold contact compensation is not required, for example, when cold contact compensation is to be made with external circuit or temperature deviation needs to be obtained.

Example) Altering cold junction compensation from ON to OFF

Key operation	Description	Display
(SEL)	Hold down the key for 9 seconds, and P-n1 is displayed. (P is displayed midway but hold it down.)	P - n 1
(V)	Press the key repeatedly until RCJ is displayed.	r [] u
(SEL)	Current data is displayed.	[] [] o n
(^) (v)	Press the (^) or (v) key to display OFF.	[] o f f
(END)	After 3 seconds, the data will be automatically registered.	
(SEL)	Hold down the key for 3 seconds to display the operation status.	1 1 9 5

PLC1

Output 1 lower limit setting (Setting range: -3.0 to 103.0%)

PHC1

Output 1 upper limit setting (Setting range: -3.0 to 103.0%)

PLC2

Output 2 lower limit setting (Setting range: -3.0 to 103.0%)

PHC2

Output 2 upper limit setting (Setting range: -3.0 to 103.0%)

(No display prior to delivery)

[Description]

- These setting is not required unless necessary especially.
- These are used when the output is contact output or SSR/SSC drive output.
- Output pulse width (ON time) is set not to lower below the set value (PLC1).
Also output pulse width (ON time) is set not to raise above the set value (PHC1). (This determines the minimum value of output OFF time).
- This function prevents flashing when combustion is controlled by ON/OFF of gas supply.

$$PLC1 = \frac{100}{TC} \times (\text{Minimum ON pulse width [sec.]})$$

$$PHC1 = 100 - \frac{100}{TC} \times (\text{Minimum OFF pulse width [sec.]})$$

TC: Proportional cycle

Related parameter: TC (Page 15)

Example) Altering lower limit pulse width limiter from 20% to 10%

Key operation	Description	Display
(SEL)	Hold down the key for 9 seconds, and P-n1 is displayed. (P is displayed midway, but hold it down.)	P - n 1
(V)	Press the key repeatedly until PLC 1 is displayed.	PLC 1
(SEL)	Press the SEL key once. Current lower limit pulse width limiter (20) is displayed.	20
(^) (v)	Press the (^) or (v) key to display 10.	10
(END)	After 3 seconds, the lower limit pulse width limiter will be automatically registered.	
(SEL)	Hold down the key for 3 seconds to display the operation status.	1195

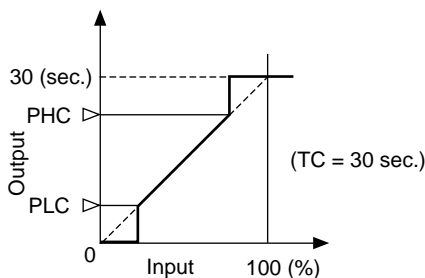

PCUT

Setting of operation mode of output limiter (Setting range: 0 to 15)

[Description]

- This function is used to set the operation mode of the output (1 or 2) limiter.
- Normally, this parameter need not be changed.
- When the output value is set to the limit set value, it is possible to set whether the output is limited by that value or it is scaled out.

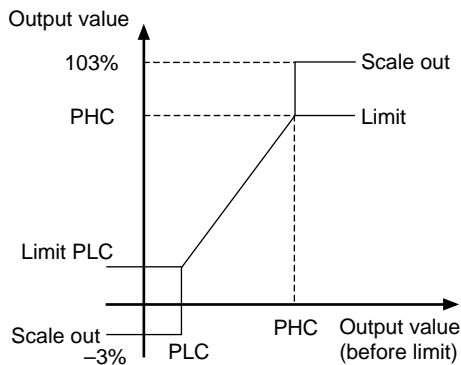

Example) Set the lower/upper limit of output 1 and output 2 to limit action

Key operation	Description	Display
(SEL)	Hold down the key for 9 seconds, and P-n1 is displayed. (P is displayed midway, but hold it down.)	P - n 1
(V)	Press the key to display PCUT.	PCUT
(SEL)	Press the SEL key to display current data.	0
(^) (v)	Press the (^) or (v) key to display 15.	15
(END)	After 3 seconds, the data will be automatically registered.	
(SEL)	Hold down the key for 3 seconds to display the operation status.	1195

PCUT	Output 1		Output 2	
	Upper limit	Lower limit	Upper limit	Lower limit
0	103%	-3%	103%	-3%
1	103%	Limit	103%	-3%
2	Limit	-3%	103%	-3%
3	Limit	Limit	103%	-3%
4	103%	-3%	103%	Limit
5	103%	Limit	103%	Limit
6	Limit	-3%	103%	Limit
7	Limit	Limit	103%	Limit
8	103%	-3%	Limit	-3%
9	103%	Limit	Limit	-3%
10	Limit	-3%	Limit	-3%
11	Limit	Limit	Limit	-3%
12	103%	-3%	Limit	Limit
13	103%	Limit	Limit	Limit
14	Limit	-3%	Limit	Limit
15	Limit	Limit	Limit	Limit

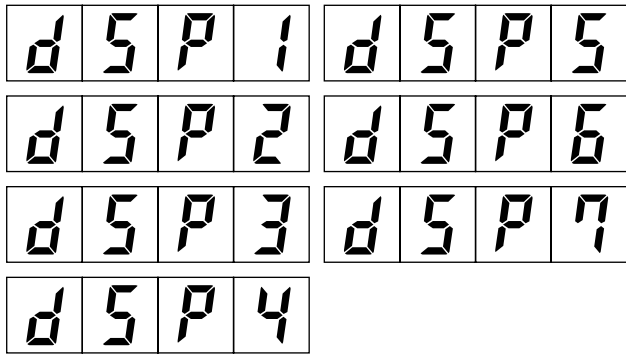

Skipping of parameter display

[Description]

- This parameter is used to skip parameter display for each item.
- This function can be used to prevent unused items from being displayed or set values from being changed by mistake.
- Correspondence of the setting of dSP1 to 7 and skipped items is shown below.
- It is possible to set the total code of items to be skipped.

Parameter	DSP allocation
PRoG	dSP1-1
H	dSP1-2
L	dSP1-4
Hb	dSP1-8
AT	dSP1-16
LoC	dSP1-32
P	dSP1-128
I	dSP2-1
D	dSP2-2
TC	dSP2-4
HYS	dSP2-8
TC2	dSP2-16
CooL	dSP2-32
db	dSP2-64
bAL	dSP2-128
Ar	dSP3-1
P-n2	dSP3-2
P-SL	dSP3-4
P-SU	dSP3-8
P-dP	dSP3-16
P-AH	dSP3-32
P-AL	dSP3-64
PVOF	dSP3-128
SVOF	dSP4-1
P-F	dSP4-2
STAT	dSP4-4
SV-1	dSP4-8
TM1r	dSP4-16
TM1S	dSP4-32
SV-2	dSP4-64

Example) Skip I and D

Set 1 + 2 = 3 according to dSP2 code table.

Key operation	Description	Display
(SEL)	Hold down the key for 9 seconds, and P-n1 is displayed. (P is displayed midway, but hold it down.)	P - n 1
↓ (∇)	Press the key repeatedly until dSP2 is displayed.	dSP2
↓ (SEL)	Press the SEL key. Current data is displayed.	□ □ □ 0
↓ (△) (∇)	Press the (△) or (∇) key to display 3.	□ □ □ 3
↓ (END)	After 3 second, the data will be automatically registered.	
↓ (SEL)	Hold down the key for 3 seconds to display the operation status.	1 1 9 5

TM2r	dSP4-128
TM2S	dSP5-1
SV-3	dSP5-2
TM3r	dSP5-4
TM3S	dSP5-8
SV-4	dSP5-16
TM4r	dSP5-32
TM4S	dSP5-64
Mod	dSP5-128
P-n1	dSP6-2
P-dF	dSP6-4
P-An	dSP6-8
RCJ	dSP6-16
PLC1	dSP6-32
PHC1	dSP6-64
PLC2	dSP6-128
PHC2	dSP7-1
PCUT	dSP7-2
FUZY	dSP7-4
ADJO	dSP7-16
ADJS	dSP7-32
OUT	dSP7-64

(Note 1) Registered function operates normally even when the display is skipped.









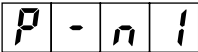

F U Z Y

FUZY control setting

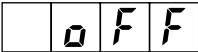
[Description]

- This function is used to select or not to select FUZY control.
- FUZY control provides the following advantages.
 - Quick start without causing overshoot.
 - Quick settlement in response to external disturbance.
- Use this function after setting P.I.D parameter to optimum value, using auto-tuning, etc.

Example) Set FUZY control to ON.

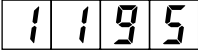
Key operation	Description	Display
	Hold down the key for 9 seconds, and P-n1 is displayed. (P is displayed midway, but hold it down.)	
	Press the key repeatedly until FUZY is displayed.	
	Press the SEL key. Current data is displayed.	
 	Press the  or  key to display ON.	
(END)	After 3 seconds, the data will be automatically registered.	
	Hold down the key for 3 seconds to display the operation status.	

Adj 0

User's adjust zero adjustment (Setting range: -50 to 50%FS)

Adj 5

User's adjust span adjustment (Setting range: -50 to 50%FS)

[Description]

- This function is used to calibrate input by user.
- Using zero input or span input, error is set in the input range.
- User calibration function is independent of adjustment of the controller. By setting 0 in this parameter, it can easily be set back to the state prior to delivery from the factory.
- It is used to set the same reading between controllers or between controller and recorder.

Example)

When the input range is 0 to 400°C, the reading at 0°C input is -1°C and that at 400°C is 402°C.

In this case, when ADJO parameter is set to 1 and ADJS to -2, the reading at 0°C input becomes 0°C and that at 400°C input becomes 400°C.

When both ADJO and ADJS are set to 0, the controller is set in the calibrated state prior to delivery from the factory.

Example) Set zero adjustment to +1°C

Key operation	Description	Display
(SEL)	Hold down the key for 9 seconds, and P-n1 is displayed. (P is displayed midway, but hold it down.)	P - n 1
↓ (V)	Press the key repeatedly until ADJO is displayed.	Adj 0
↓ (SEL)	Press the key. Current data is displayed.	□ □ □ 0
↓ (^) (V)	Press the (^) or (V) key to display 1.	□ □ □ 1
↓ (END)	After 3 seconds, the data will be automatically registered.	
↓ (SEL)	Hold down the key for 3 seconds to display the operation status.	1 1 9 5

Setting of ramp/soak control (ProG) (option) (roff/rrUn/rHLd)

[Description]

- This function is used to change time and set value (SV) automatically according to preset pattern. Up to 4 ramp/soak programs can be used.
- The No. 1 ramp starts from measurement value (PV) just before the execution of program.
- It is also possible to run the program automatically at power ON (power ON start function).

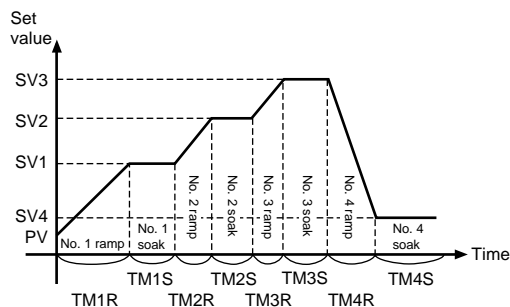

Ramp.....Range of change in set value toward target value
Soak Range of unchanged set value, the same as target value

Related parameter: STA (Page 29)
SV-1 ~ SV-4 (Page 29)
TM1r ~ TM4r (Page 29)
TM1s ~ TM4s (Page 29)

Example) Start ramp/soak operation (rrUn) from local operation (roFF)

Key operation	Description	Display
(SEL)	Hold down the key for 3 seconds.	r o F F
(^) (v)	Press the (^) or (v) key to display r r U n .	r r U n
(END)	After 3 seconds, commands of ramp/soak control will be automatically registered. Start operation according to preset ramp/.soak patterns.	
(SEL)	Hold down the key for 3 seconds to display the operation status.	1 1 9 5

Troubleshooting

When trouble arises with the unit, check and remove the cause referring to the following table of troubleshooting.

Trouble	Cause	Remedy
Data are no displayed.	(1) Power is not supplied. (2) Unit is not connected to connector. (3) Instrument is in trouble.	(1) Check power source. (2) Connect unit firmly to connector. (3) Replace instrument or contact your dealer for advice.
PV display is UUUU or LLLL .	(1) Measured value is very high or low. (2) Input is not connected. (3) Sensor is damaged.	(1) Check temperature of controlled object. (2) Connect input terminal. (3) Replace sensor or contact your dealer for advice.
Data are not changed at press of key.	(1) Unit is set in the position where parameter cannot be changed. (2) Unit is set over data setting range.	(1) Check set value of parameter LoC (Page 11). (2) Check set values of parameter P-SL (Page 22) and P-SU (Page 22)
HB lamp ON	(1) Lamp is ON at detection of heater burnout.	(1) Remove the cause of heater burnout.
Control output is not ON when output lamp (C1, C2) is ON.	(1) Output is disconnected. (2) Instrument is in trouble.	(1) Check connection of output terminal. (2) Replace instrument or contact your dealer for advice.
Hunting of PV	(1) Input filter time constant is small. (2) Hysteresis is very large for 2-position action. (3) Control output proportional cycle is very large. (4) Improper adjustment of PID	(1) Check set value of parameter P-dF (Page 31). (2) Check set value of parameter HYS (Page 16). (3) Check set value of parameter TC (Page 15), and TC2 (Page 16) control output 2. (4) Perform auto-tuning (Page 10).
Auto-tuning is not finished.	(1) Wrong wiring (2) Wrong setting of normal/reverse action of controller (3) Time constant of measured object is very long.	(1) Check wiring between control object and controller. (2) Check set value of parameter P-n1 (Page 30). (3) It takes time for time constant. Wait until it is set.