

Manual



P-2000 P-2020

P-2000 Ex

P-2020 Ex

P-2050



Contents

	Page
Function	5
Air preparation	6
Installation	6
1. Calibration	
1.1 Cam setting	7
1.2 To change the action	7
1.3 Gain adjustment	7
1.3.1 To reduce the gain	8
1.4 Zero adjustment	8
1.5 Range adjustment Maintenance	8
2.1 The restriction plug	8
2.2 To clean the valve body	8-9
2.3 To replace the diaphragms	9-10
Trouble shooting	11
Ex installation	12-13
Exploded drawing	14
Dimensional drawing	15



GB

Manufacturers declaration

in compliance with EC directive 89/392/EEC/89/336/EEC, & 92/31/EEC

We hereby confirm that the appliances described in this sheet has been manufactured in compliance with the applicable standards and is intended for installation in a machine/application, and that commissioning is strictly prohibited until evidence has been provided that the machine/application in question is also in compliance with

EC directive 89/392/EEC/89/336/EEC, and 92/3/EEC.

This manufacturers declaration is applicable to the following PMV series:

P-2000/P-2020/P-2050/P-2000Ex/P-2020Ex

D

Hersteller-Erklärung

im Sinne der EG-Richtlinie 89/392/EWG/89/336/EWG, & 92/31/EWG

Hiermit erklären wir, daß die in diesem Blatt beschriebenen Geräte entsprechend den gültigen Normen gebaut und zum Einbau in eine Maschine oder Applikation bestimmt sind, sowie daß deren Inbetriebnahme so lange untersagt ist, bis festgestellt wurde, daß diese

Maschine/Applikation ebenfalls der EG-Richtlinie

89/392/EWG/89/336/EWG, 92/3/EWG entspricht.

Diese Herstellererklärung hat für folgende PMV-Serien Gültigkeit:

P-2000/P-2020/P-2050/P-2000Ex/P-2020Ex

F

Déclaration de fabricant

au sens de la directive de la 89/392/CEE/89/336/CEE, & 92/31/CEE.

Nous déclarons par la présente que les appareils décrits sur cette page sont construits en conformité avec les normes en vigueur et qu'ils sont destinés à être montés dans une machine ou une application, nous déclarons également que leur mise en service est interdite tant qu'il n'a pas été constaté que cette machine/application satisfait

également à la directive 89/392/EEC/89/336/EEC, 92/3/EEC.

Cette déclaration de fournisseur est valable pour les types d'appareils PMV suivants:

P-2000/P-2020/P-2050/P-2000Ex/P-2020Ex



*Mr. Jan-Eric Andersson
President, Palmstiernas Instrument AB*



PMV Positioner storage and handling procedures

PMV Positioners are precision instruments which should be stored and handled accordingly to avoid problems or damage.

Appropriate precautions should be taken to protect units while in storage.

Warehouse storage

Stored in original PMV shipping containers, units should be stored in an environmentally controlled area, i.e. clean, cool (15-26°C, 6-80°F) and dry, out of direct sunlight or weather exposure.

Field storage

Note: Once air supply to the positioner is connected and turned on, internal air bleed will prevent the ingress of moisture and protect the unit from corrosion. It is recommended that the air supply be left on at all times.

- If units are installed immediately, turn, and leave on, the air supply.
- If positioner must be stored outdoors, tighten all covers which may loosened in shipment, make sure all open enclosure entry points are sealed.

Positioners should be wrapped and sealed air and watertight with desiccant inside the plastic, units should be securely covered with an opaque cover and not exposed to direct sunlight, rain or snow.

Potential damage mechanism

When units are stored in hot, humid climates, the daily heating/cooling cycle will cause air to expand/ contract and be drawn in and out of the positioner housing.

Dependent on the local temperature variations, humidity, dew points and the time in storage condensation could occur and accumulate inside causing erratic operation or failure due to water or corrosion. The potential for condensation damage is especially high in southern climates and aggravated if units are exposed to direct sunlight.

For further assistance, please contact your nearest PMV office.



Function

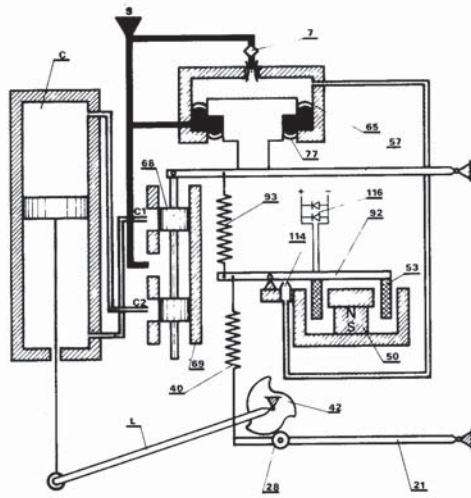

(For figure of componets,
please see LIST OF
SPARE PARTS)

- Nozzle Pressure
- Supply Pressure
- Moving Parts
- Fixed Parts
- Cylinder Pressure

The PMV E/P Positioner function is based on torque balance. Direct current, 4-20 mA or 0-20 mA acting as input signal creates, in the force coil (53) in the permanent magnet (50) field, a force proportional to the signal and, on the beam (92), a corresponding torque. The position of the cylinder (C) piston is converted by means of the feedback linkage (L), cam (42), lower arm (21) and spring (40), to a force proportional to the position of the cylinder (C) piston and, on the beam (92) a counter torque. When in balance, the cylinder position equals the input signal value.

The nozzle (114) without friction senses the balance of the beam (92). When, for example, the signal is increased the torque corresponding to the signal on the beam (92) will increase and the beam (92) will turn clock-wise. The nozzle (114) closes, and the nozzle pressure increases. The diaphragm assembly moves downwards as does the spool (68) of the pilot valve activated by the balance arm (57). Supply airflows through connection C2 and air from the "minus" chamber of the cylinder (L) is exhausted through connection C1.

Differential pressure is created in the cylinder, and the piston will travel "plus" until the torque change on the beam (92), created by the piston position change, rebalances the beam (92) position and the nozzle pressure. The diaphragm assembly will return to equilibrium position with the balance arm (57) guiding the spool (68) to mid position. The piston of the cylinder (C) will stop in the position corresponding to the new input signal.

A change in position of the balance arm (57) creates, through the spring (93), a negative feedback torque on the beam (92). Stable operation is thus achieved in spite

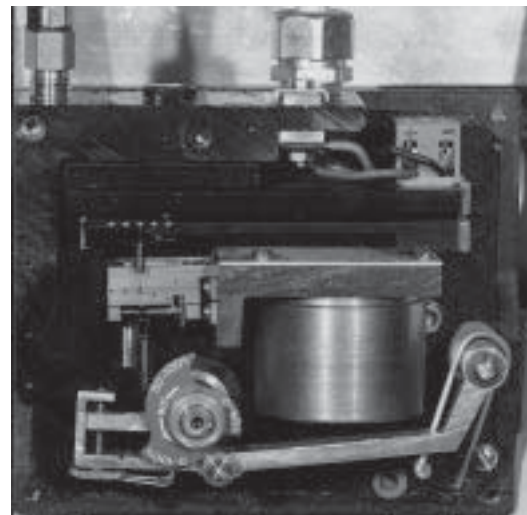

of possible great static amplification or sensitivity. The position of the spring (93) can be changed along the beam (92) and the balance arm (57) in order to adjust positioner gain, and thus the dynamics of the positioner. The positioner can be adjusted to match any small or large actuator.

The lower arm (21) has a mechanism for zero adjustments. The beam (92) has the mechanism for adjusting the range. To reverse the positioner action the cam (42) is flipped over and the pipe connections C1 and C2 are interchanged.

Split range is available by choosing the right curve on the cam (42). Non-linear function is achieved by reshaping the cam (42). Such cams are available from PMV.

The PMV E/P Positioner can also be used as a single acting positioner by simply plugging one of the ports C1 or C2.



Air preparation

The PMV ELECTRO-PNEUMATIC Positioner can work with supply pressure up to 8 bar (120 Psi”). In order to obtain a satisfactory operation and high reliability a filter (25 microns) should be placed as close to the Positioner as possible. For larger pressure variations of the supply air (or the supply pressure is too high) a pressure regulator should be mounted next to the filter in order to eliminate the fluctuations. The supply air must be dry, clean and free from oil.

Installation

The PMV E/P Positioner is available with a large selection of feed back spindle designs to simplify the mounting on the actuator.

Ports C I and C2 are to be connected to the actuator.

Port S is to be connected to the air supply (max 8 bar or 120 psi³ which should be of instrument quality (clean, dry and oil free). If your supply pressure is too high and/or the supply pressure changes from time to time you must use a pressure regulator.

Port I is to be used for the electrical connection gland. This connection is 1/2~ NPT or PG 13.5 (M- 20) internal thread.

Input signal: 4-20 mA; 0-20 mA

Input resistance: 240 Ohm \pm 10%

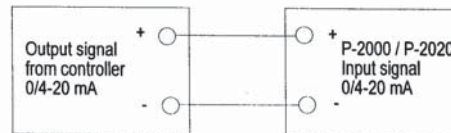

Important notice

P-2000 Ex/P-2020 Ex should be connected to intrinsically safe circuits only. See installation dwg for further details.

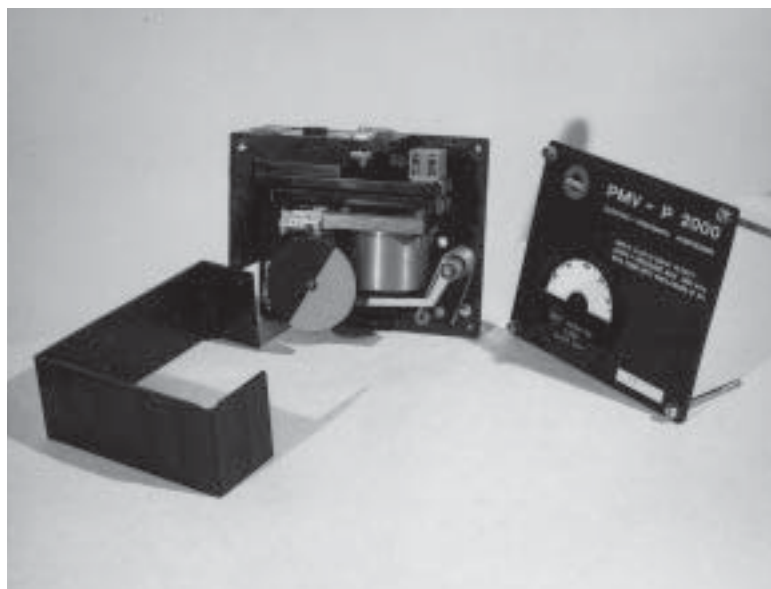

The PMV Positioner with the cover (33) and the side frame (3) dismantled.



1. Calibration

PLEASE NOTICE: For easy access to important parts please back off the four screws. Remove the cover.

Fig 1



Figure 1

The side frame can be removed by simply pressing out one end of the frame from the slot in the main frame.

Fig 2



Figure 2

NOTE: P-2000 series positioner are factory calibrated to 4-20 mA input signal. Start by adjusting zero first, then stroke the unit and check reading before further adjustments.

1.1 Cam setting

After mounting the PMV Positioner on your actuator and before switching on the supply air, if possible, manually operate the actuator from fully open to fully closed position and check that the cam is correctly oriented. Make adjustments if necessary (see instructions below).

Should manual operation of the actuator not be possible we recommend you to back off the nut holding the cam.

Fig 3



Figure 3

Adjust the position of the cam so that the ball bearing on the lower arm rests on the lowest part on the correct curve of the cam. You have three different curves to choose from on the standard cam (0-100, 0-50 or 50-100 % of the control signal for the full stroke of the actuator).

Position the cam as shown. The ball bearing should not ride on the inactive portion of the cam. Tighten the nut.

Fig 4

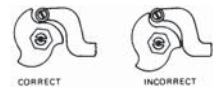

Figure 4

NOTE: The cam will turn slightly with the nut as it is tightened. Be sure to allow for this slight clockwise rotation.

1.2 To change the action

To change the action, the cam must be flipped over and the tubes to the connections C1 and C2 must change places.

Fig 5



Figure 5

1.3 Gain adjustment

PLEASE NOTE: Before adjusting the gain please switch of the supply pressure.

The gain suppression spring can be moved along the beam and the balance arm. The feedback stiffness can thus be adjusted so that the PMV Positioner dynamics matches the actuator size.

Fig 6&7

You will find a number of positioning holes in the beam and the balance arm for the spring. The smaller the actuator the lower is the acceptable level of the gain.

High gain



Figure 6

Low gain



Figure 7



1.3.1 To reduce the gain

Move the spring to the left. Please use a pair of tweezers when moving the spring.

Fig 8

Changing the position of the spring effects the zero adjustment and new zero adjustment is necessary (see 1.4 below).

1.4 Zero adjustment

Set the input signal at 4 mA (or 0 mA for 0-20 mA control range) and switch on the air supply.

When turning the zero setting screw to the right the actuator will move in the direction of the decreasing signal. Adjust the screw until the actuator is in the "starting" position.

Fig 9

1.5 Range adjustment

Set the input signal at its final value e.g. 20 mA.

If the turning angle of the actuator is too large (small) a downwards (upwards) rotation of the range adjustment screw will reduce (increase) the actuator travel.

Fig 10

The range and zero adjustments has a small effect on one and other. Therefore a few zero and range adjustments might be needed in turns.

PLEASE NOTICE: Should the zero adjustment reach the limit you might be helped by using the other spring mounting on the spring guide. Use a pair of tweezers to change the position of the spring.

Fig 11

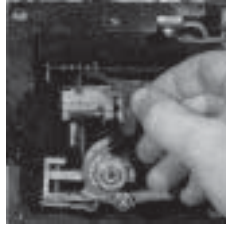

Figure 8

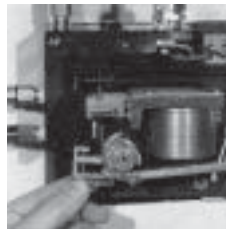

Figure 9



Figure 10

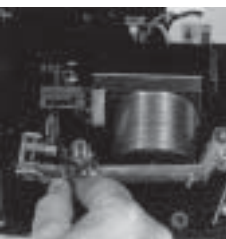

Figure 11

2. Maintenance

The permanent magnet has a very strong magnetic field and in order to avoid iron dust entering into the narrow gap for the force coil you should never leave the PMV E/P Positioner without the cover mounted.

Regular maintenance of the PMV E/P Positioner is not required. The need for maintenance is depending on your supply air quality. Should iron dust enter into the magnet, restricting the free movement of the force coil, this would cause disturbances.

2.1 The restriction plug

Close to the connection (S) for the supply air you will find the restriction plug which is easily removable for exchange. Before replacing the restrictor plug please check that the Orings are in good condition.

Fig 12

2.2 To clean the valve body

Unscrew the four screws and remove the cover.

Fig 13

Remove the side frame.

Fig 14



Figure 12



Figure 13



Figure 14



Remove the screw (30) and the indicator.
Fig 15



Figure 15

Remove the nut and the cam.
Fig 16

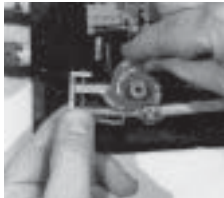

Figure 16

Remove the three screws holding the valve body. Be careful not to damage the Magnet unit.
Fig 17



Figure 17

Carefully remove the valve body. Handle so that the spool slides easily and does not bind against the tip of the balance arm.
Fig 18



Figure 18

Pull the spool out of the valve body.

Wash the components in a solvent using e.g. a pipecleaner for the valve body and blow the internal of the valve body clean and dry using compressed air.

Parts should be handled with caution. Spool and valve body are matched together and can not be changed separately.

The spool should move freely in the valve body and with the spool oriented in the "closed position" the play between the spool and the valve body seats should be fairly tight. Should it be possible to move the spool in the radius direction due to wear or if the spool cannot be moved freely along its axes the valve body with the spool must be exchanged.

Before refitting the valve body and spool check that the O-rings are mounted and in good condition. Take care not to damage the leaf springs on the tip of the balance arm. Both leaf springs must be in the gap of the spool. Using a small screw driver to flatten the leaf springs will help you slide the spool in place.

Fit the screws and tighten the screws a little at a time.
Fig 19

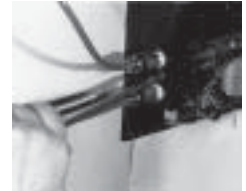

Figure 19

2.3 To replace the diaphragms

Back off the four screws and remove the cover. See fig 13. Remove the sideframe. See fig 14. Remove the screw and the indicator. See fig 15. Remove the nut and the cam. See fig 16.

Disconnect the control signal wires.
Fig 20



Figure 20

Use a pair of pliers to unload the tension of the spring by lifting the end of the spring over the screw.
Fig 21



Figure 21

Remove the screws and the valve body. See fig 17 and 18.

Remove the screws.
Fig 22



Figure 22



Carefully lift out the E/P converter.
Fig 23

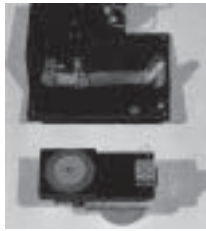

Figure 23

The middle section can now be separated from the body.
Fig 26



Figure 26

Remove the gain suppression spring by using a pair of tweezers.
Fig 24

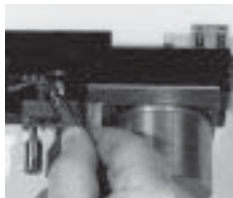

Figure 24

Pull the diaphragm-piston assembly upwards apart from the middle section.
Fig 27

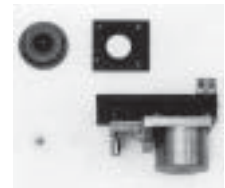

Figure 27

Loosen the screw and be careful to use a holding-up tool for the retainer to avoid tension on the diaphragms.
Fig 25



Figure 25

Replace the broken diaphragm and assembly the positioner step by step following the opposite order in which you now have disassembled it.

Be sure to check that all O-rings are in good condition and in the proper places.



Trouble Shooting

Signal change has no effect on the actuator position.

- Make sure the supply pressure is switched on.
- Signal wires are wrongly connected.
- The wiring between the terminal block and the printed circuit board on the force coil is broken. Check resistance.
- Pipe connections between the PMV Positioner and the actuator is wrong.
- A wrong portion of the cam is being used.

With a small change in the control signal the actuator runs to the end position.

- Pipe connections between the PMV Positioner and the actuator is wrong.

Inaccurate positionmg

- Dirty valve body.
- Dirty restrictor or nozzle.
- Iron dust in the magnet gap.
- Defective diaphragms.
- The sizing of the actuator is incorrect. Output torque of the actuator is too small or the supply pressure is too low.
- Torque requirement of the valve has increased.

Overshoot or hunting during positioning.

- Internal gain is too high.
- Capacity of the supply pipe is too small or air filter is clogged. In this event the input pressure to the PMV Positioner drops steeply when the pilot valve feeds air into the actuator.



Physikalisch-Technische Bundesanstalt



CERTIFICATE OF CONFORMITY

PTB Nr.Ex. 86.B.2011

(1) This certificate is issued for the Electrical Apparatus

(2) Electro-Pneumatic Positioner type PMV P-2000 Ex and P-2020 Ex

(3) Manufactured and submitted for certification by Palmstiernas Mekaniska Verkstad AB S-113 57 Stockholm, Sweden

(4) This Electrical Apparatus and any acceptable variation thereto is specified in the Annex to this Certificate.

(5) The Physikalisch-Technische Bundesanstalt (PTB), approved certification body in accordance with Article 14 of the Council Directive of the European Communities of 18 December 1975 (76/117/EEC), confirms that the Apparatus has been found to comply with the harmonized European standards

Electrical apparatus for potentially explosive atmospheres

EN 50 014:1977 + A1...A4 (VDE 0170/0171 Teil 1/5.84) Allgemeine Bestimmungen
EN 50 020:1977 + A1 (VDE 0170/0171 Teil 7/5.78) Eigensicherheit "1"

after having successfully met the examination and test requirements which are recorded in a confidential Test Report.

(6) The Apparatus marking shall include the following code
EEx ib IIC T6 bzw. EEx ib IIC T5 bzw. EEx ib IIC T4

(7) The manufacturer has the responsibility to ensure that the Apparatus bearing the marking conforms to the specification laid down in the Annex to this Certificate and has satisfied the prescribed routine verifications and tests.

(8) This Electrical Apparatus may be marked with the Distinctive Community Mark shown above and specified in Annex II to the Council Directive of 6 February 1979, (79/196/EEC).

For and on behalf of PTB
(signature)
(Dr.-Ing. Schebsdat)
Oberregierungsrat
Braunschweig, 28.01.1986

Test certificates without signature and official stamp are not valid.
No alteration may be made to copies of this test certificate.
Extracts or changes may be made only with the permission of the Physikalisch-Technische Bundesanstalt, Bundesallee 100, Postfach 3345, D-3300 Braunschweig

V 15 - 200007 - 10 86

Physikalisch-Technische Bundesanstalt

APPENDIX

to Certificate of Conformity, PTB Nr. Ex - 86.B.201

This electro-pneumatic valvepositioner controls the position (0-90 degrees e.g.) of a pneumatic actuator related to the input signal (4-20 mA, 0-20 mA).

As pneumatic energy serves a non-inflammable gas.

The temperature classifications related to the short circuit current of the intrinsically safe signal source are as follows

Short circuit current of the intrinsically safe signal source	Ambient temperature	Temperature classification code
85 mA	80 °C	T4
110 mA	80 °C	T4
85 mA	80 °C	T5
110 mA	75 °C	T5
85 mA	70 °C	T6
110 mA	60 °C	T6

Data

Signal current circuit ... in protective systems types to be connected only to certified intrinsically safe circuits with the following maximum values:

Open circuit voltage U = 28 V
Short circuit current I = 85 mA resp.
I = 110 mA
(ref. above list)

The internal effective inductance and capacitance are negligible.

Test Documents

1. Description (6 sheets) signed 17/10 1985
2. Drawing Nr. 13299 of 12/3 1985
- 13428 of 15/8 1985
- 13210 of 20/8 1985
- 2000 TY a of 24/10 1985

For and on behalf of PTB
(signature)
(Dr.- Ing. Schebsdal)
Oberregierungsrat
Braunschweig 28/1 1986

35012 1.81



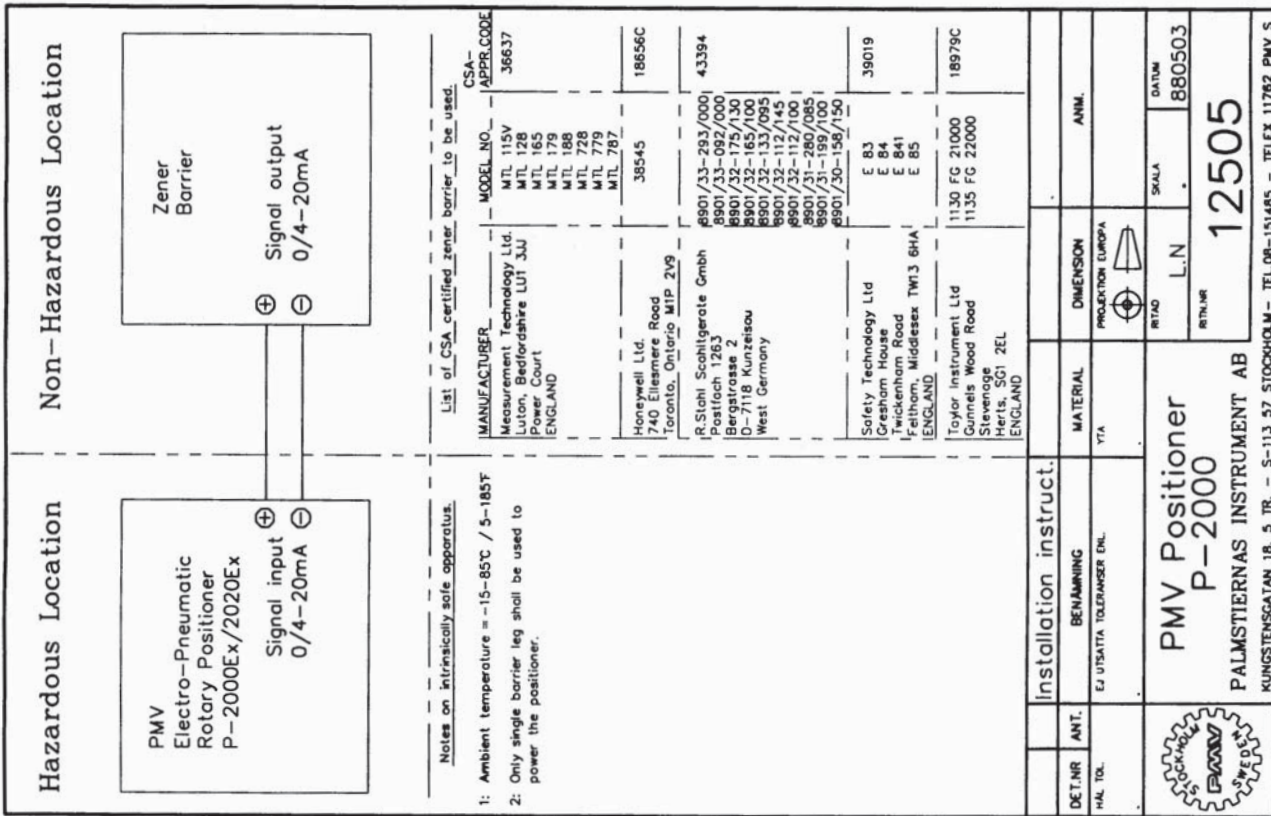

This document must not be copied without our written permission and the contents thereof must not be reported to a third party nor be used for any unauthorized purpose. Convention will be proscribed.

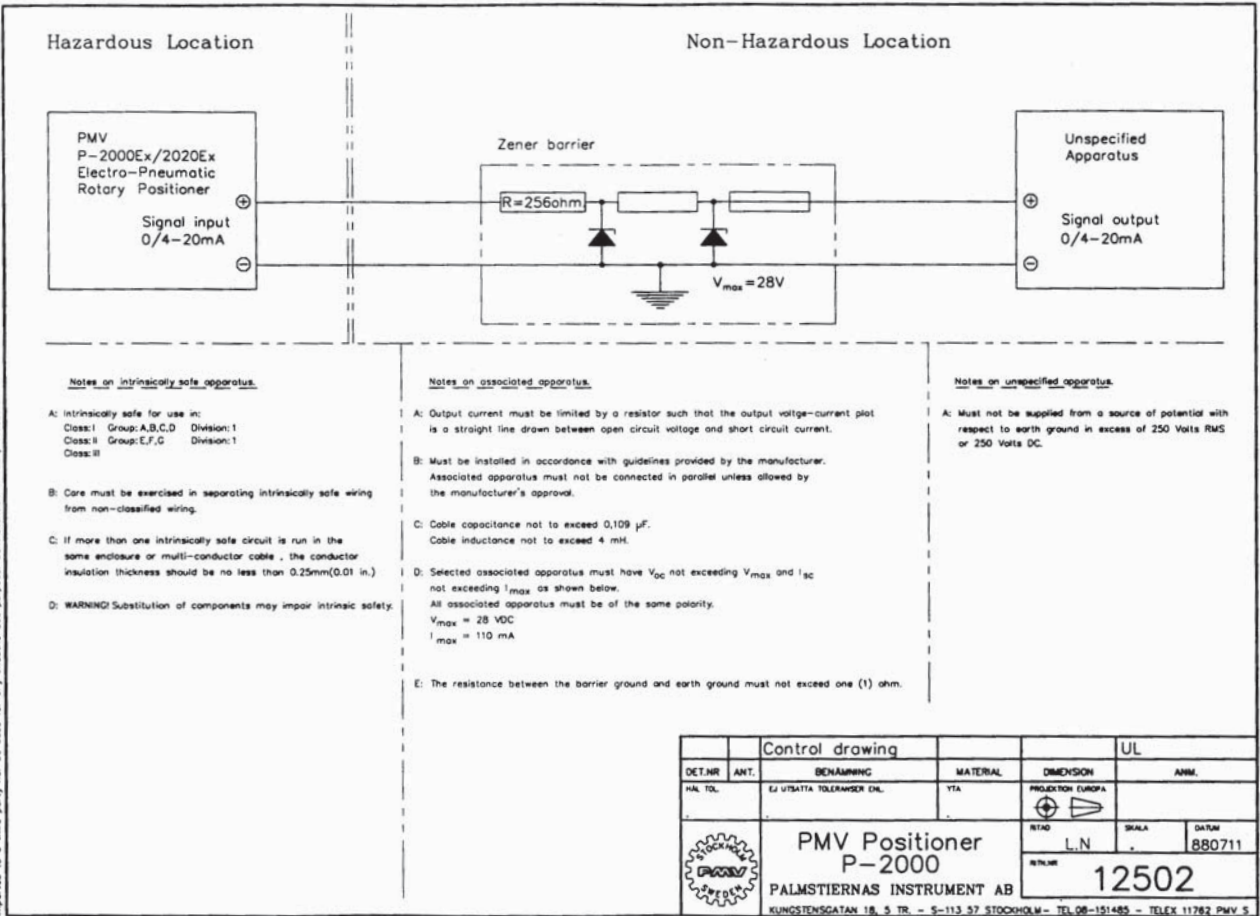

This document must not be copied without our written permission and the contents thereof must not be reported to a third party nor be used for any unauthorized purpose. Convention will be proscribed.



Exploded drawing

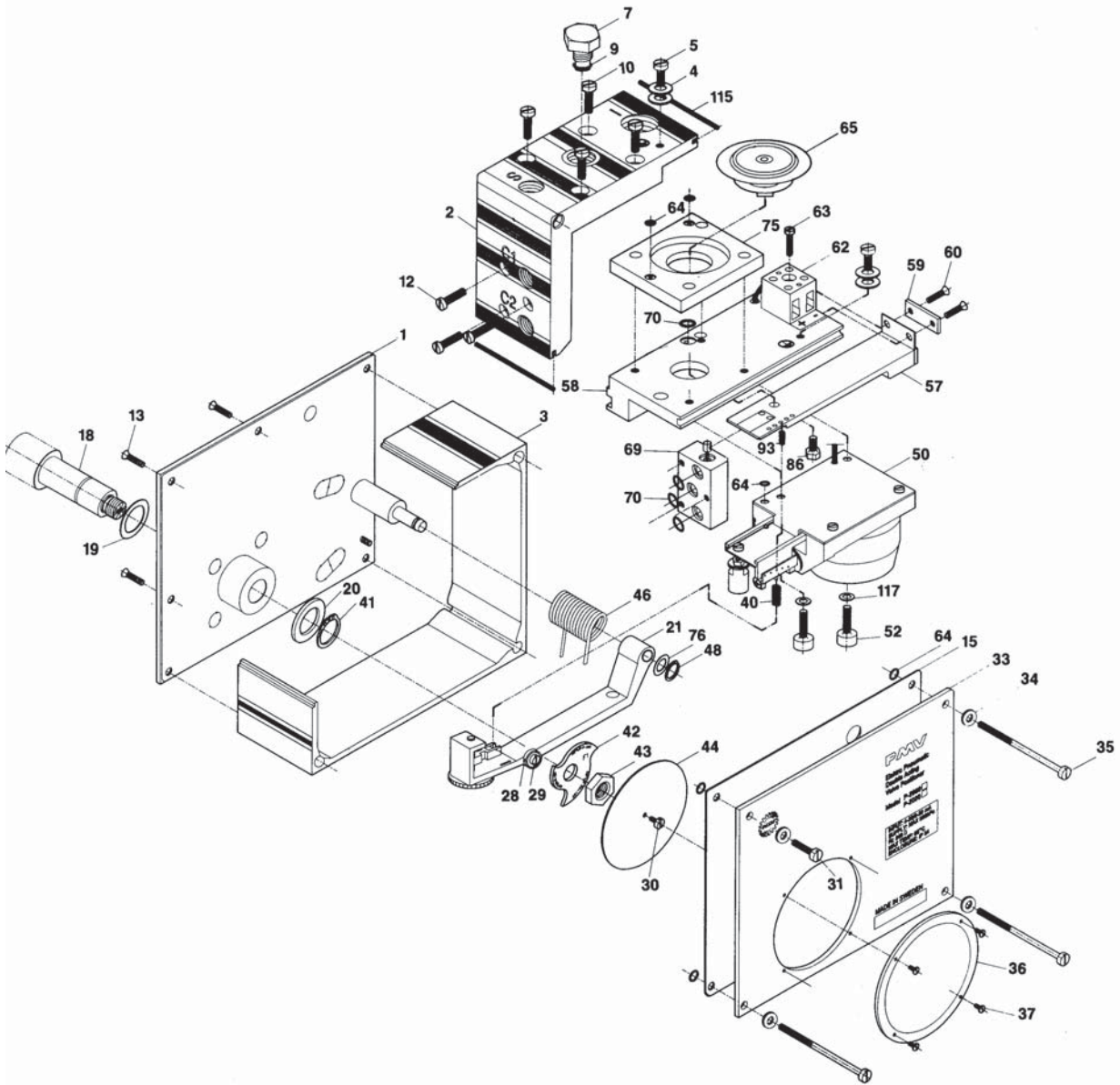

Dimensional drawing

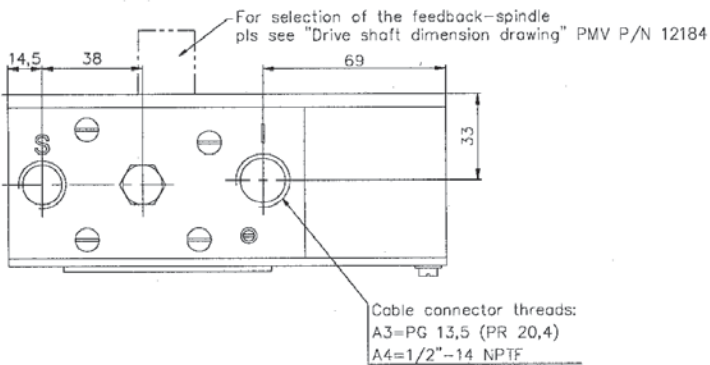
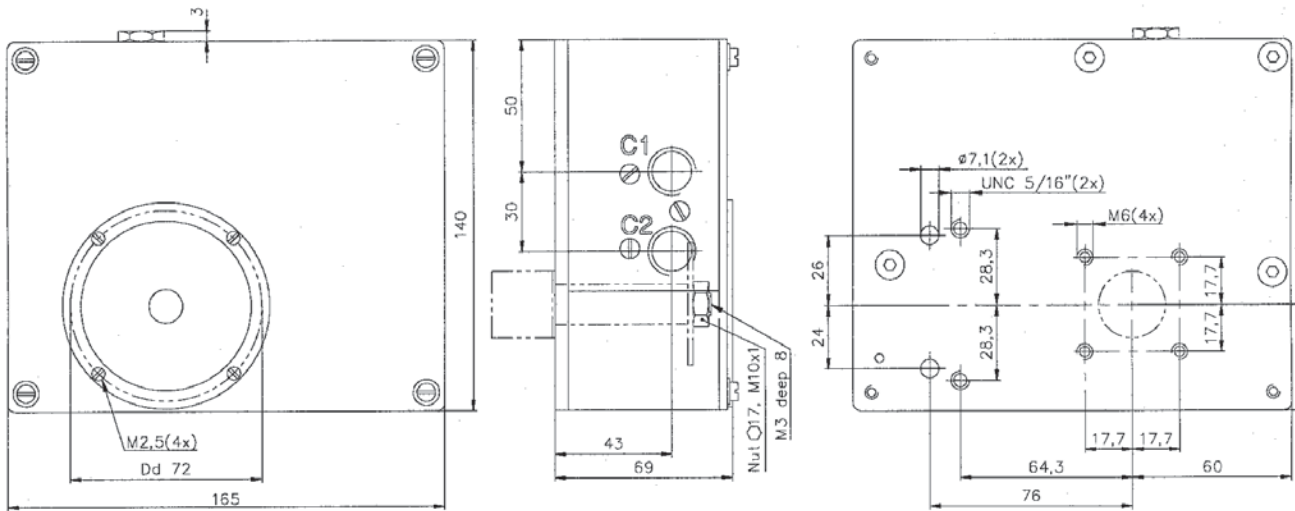

Order information:
A3 for G 1/4"-19 male connectors
A4 for 1/4"-18 NPT male connectors





Palmstiernas Instrument AB
Tulegatan 15
SE-113 53 Stockholm
SWEDEN
Tel: +46 (0) 8 15 14 85
Fax: +46 (0) 8 673 39 83
E-mail: info@pmvpositioners.com
Internet: www.pmvpositioners.com



SUBSIDIARIES:

Coulton Instrumentation Ltd
17 Somerford Business Park
BH23 3RU Christchurch
ENGLAND
Tel: +44 1202 480 303
Fax: +44 1202 480 808
E-mail: sales@coulton.com

PMV-USA, Inc
1440 Lake Front Circle
Unit 160
The Woodlands, Texas 77380
USA
Tel: +1 281 292 7500
Fax: +1 281 292 7760
E-mail: pmvusa@pmvusa.com
Internet: www.pmvusa.com

PMV Regeltechnik GmbH

Losensteinleiten 7
A-4493 Wolfers
AUSTRIA
Tel: +43 (0) 7253 82410
Fax: +43 (0) 7253 82419
E-mail: aw.pmv@ambos.co.at

PMV GmbH

Postfach 2310
D-41554 Kaarst
GERMANY
Tel: +49 (0) 2131 667 081/82
Fax: +49 (0) 2131 667 083

Palmstiernas Svenska AB

Box 21
SE-663 21 Skoghall
SWEDEN
Tel: +46 (0) 54 52 14 70
Fax: +46 (0) 54 52 14 42
E-mail: info@palmstiernas.se
Internet: www.palmstiernas.se

(The information in this brochure is subject to change without notice.)

Distributor