



BOURDON tube TEMPERATURE SWITCHES
EXPLOSIONPROOF Execution

Serial/Series

TAG

pag. 1/4

IP IP66 / NEMA 4X



IECEX

GAS Ex d IIC T6/T4 Gb
DUST Ex tb IIIC T85/T135 Db



ATEX



II 2 GD

Su richiesta / on request



GOST R
TR CU



INMETRO
CEPEL



KCS
KOSHA



APPROVED
IEC 61508



Termostato con capillare /
temperature switch with capillary

Per la terminologia usata in questo prospetto, v. PT-B0-20.

CARATTERISTICHE GENERALI DELLA SERIE TAG

- **COSTRUZIONE ELETTRICA:**
Grado di protezione IP66 (NEMA 4X)
Classe sicurezza elettrica: classe I (EN61298-2:1997-06)
Modo di protezione (std): a prova di esplosione
GAS Ex d IIC T6/T4 Gb
POLVERI Ex tb IIIC T85/T135 Db
- **CUSTODIA:** cassa e coperchio in lega di alluminio esente da rame e sue leghe, accoppiamento filettato con dispositivo di blocco. Verniciatura epossidica.
Passaggio cavi: 1/2-14 NPT-F std. - opz. (vedi punto 5 a tergo).
Morsettiera: terminali a vite adatti per capicorda.
Materiale isolante PA (UL 94V-0).
Viti di messa a terra: una interna e una esterna.
Sezione massima cavi di terra: 4 mm².
Targa: in acciaio inox con scritte indelebili, marcate con laser
- **CONTATTI ELETTRICI:** uno o due microinterruttori SPDT a **differenziale fisso**; un microinterruttore SPDT a **differenziale regolabile** (vedi punto 1 a tergo).
La funzione DPDT viene svolta da due micro SPDT con scatto **simultaneo** entro lo 0,2% ampiezza campo.
- **ELEMENTO TERMOMETRICO:** a riempimento di gas (classificazione SAMA III B) costituito da:
- Bulbo in AISI 316.
- Attacco in AISI 304 scorrevole con premistoppa.
- Capillare in AISI 316 con protezione flessibile inox.
- **CAMPI:** da -30°C a +600°C (vedi punto 3 a tergo).
- **PUNTO DI INTERVENTO:** regolabile su tutto il campo.
Due punti di intervento indipendenti (n° 2 contatti SPDT) con distanza maggiore del 5% del campo.
Ripetibilità: migliore di 0,5% dell'ampiezza campo.
Regolazione interna del punto di intervento tramite vite con dispositivo antiallentamento.
Nota: quando il punto d'intervento è vicino (meno del 10% dell'ampiezza campo) alla temperatura normale di funzionamento, lo strumento deve essere installato in un luogo esente da vibrazioni e non esposto ad urti accidentali.
- **MONTAGGIO:** verticale (attacco verso il basso):
Distanziato con capillare,
- std. a parete tramite fori di fissaggio sulla cassa.
- (opzione) su tubo da 2" (con staffa opz. In AISI 304);

For terminology used in this data sheet, see PT-B0-20E.

GENERAL FEATURES OF SERIES TAG

- **ELECTRIC CONSTRUCTION:**
Degree of protection IP66 (NEMA 4X).
Electrical safety class: class I (EN61298-2:1997-06)
Protection mode (std): explosion-proof
GAS Ex d IIC T6/T4 Gb
DUST Ex tb IIIC T85/T135 Db
- **ENCLOSURE:** case and cover copper free aluminium alloy, threaded coupling with tamper proof device. Epoxy painting.
Cable entry: 1/2-14 NPT-F std. - opt. (see point 5 overleaf).
Terminal block: screw-type terminals suitable also for cable lugs. Insulating material PA (UL 94V-0).
Earthing screws: one inside, one outside.
Max section of earthing wires: 4 mm².
Data plate: in stainless steel with indelible data by laser marking.
- **ELECTRICAL CONTACTS:** One or two microswitches SPDT with **fixed dead band**; one microswitch SPDT with **adjustable dead band** (see point 1 overleaf).
The function DPDT is obtained by two micro SPDT with **simultaneous** action to within 0,2% of span.
- **THERMAL ELEMENT:** inert gas filled system (classification SAMA III B) consist of:
- Bulb AISI 316.
- Connection AISI 304 compression fitting with adjustable insertion length.
- Capillary AISI 316 with stainless steel flexible armor.
- **RANGES:** from -30°C a +600°C (see point 3 overleaf).
- **SET POINT:** adjustable throughout the range.
Two independent set points (n° 2 SPDT contacts) with a gap higher than 5% of range.
Repeatability: better than 0,5% of span.
Internal set point calibration by means of adjustment screw with anti-loosening device.
Note: when the set point is close (less than 10% of span) to normal working temperature, the device must be installed in a vibration free location, and mechanical shocks must be avoided.
- **MOUNTING:** vertical (with connection downwards):
Remote with capillary, sensors type C:
- std. at surface/wall through holes on the case;
- (option) 2" pipe with bracket in AISI 304.



ALTA QUALITÀ COSTANTE dal 1897
CONSTANT HIGH QUALITY since 1897

COMPANY WITH
MANAGEMENT SYSTEM
CERTIFIED BY DNV
= ISO 9001 =
= ISO 14001 =

- **TEMPERATURA AMBIENTE (limite operativa \ominus):** -40/+85°C
AMBIENT TEMPERATURE (operative limit \ominus): -40/+85°C

① limite operativa in accordo a ISA S51.1
 operative limit according to ISA S51.1

- **MANUALE DI ISTRUZIONI:** NI-401
INSTRUCTION MANUAL: NI-401E

APPARECCHIATURA certificata in accordo a:
EQUIPMENT certified according to:

- **IECEX IEC 60079-0, -1, -26, -31**

- **ATEX Directive 94/9 EC Annex III, IV.**

Nota: doppia marcatura, ATEX e IECEX, su unica targa
 Note: double marking, ATEX and IECEX, on single plate

Su richiesta / on request:

- **KCS - KOSHA**

- **INMETRO - CEPEL**

- **TR CU 012/2011 - GOST R**

- **IEC61508 Functional Safety:** approved for use in SIL 2 safety related systems.

DIMENSIONI [mm] e PESI [kg] DIMENSIONS [mm] and WEIGHTS [kg]

Remoto capillare / Remote capillary

Peso / Weight: 2,6 kg (capillary 2m) + 0,1 kg each meter of capillary

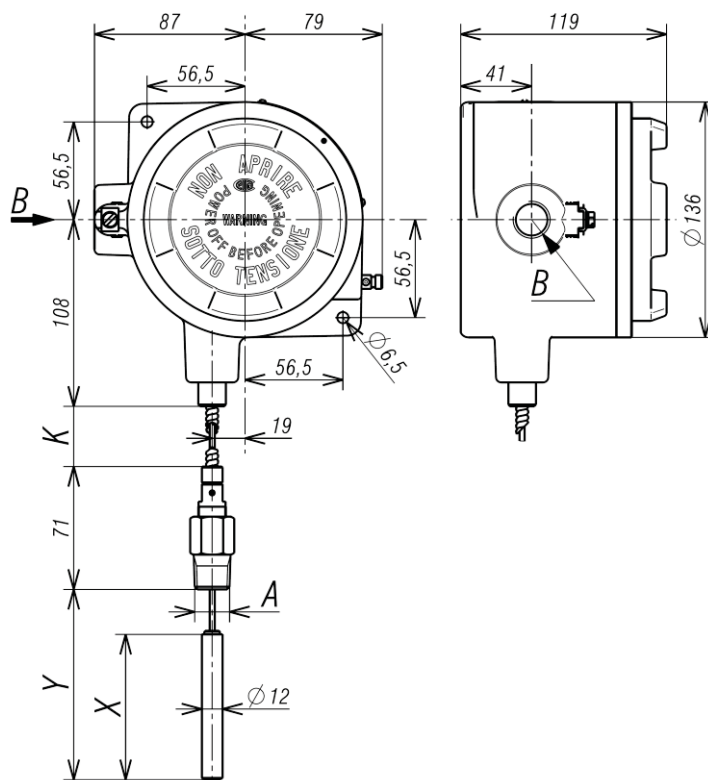

A = attacco bulbo / bulb connection E = passaggio cavi / cable entry

Nota per termostato con capillare

K = lunghezza del capillare: 2 m, 4 m, 6 m, 8 m, 10 m
 La lunghezza di inserzione (quota Y, vedi disegno) può essere aumentata fino al valore (K•150) mm. Si ridurrà quindi la lunghezza "K".
 Esempio: K=6 m, Ymax.= 6•150 = 900 mm

Note for temperature switch with capillary

K = length of capillary: 2 m, 4 m, 6 m, 8 m, 10 m
 The insertion length (dimension Y, see drawing) can be varied up to (K•150) mm. The length K is reduced accordingly.
 Example: K=6 m, Ymax.= 6•150 = 900 mm

Connessioni elettriche e viti di regolazione

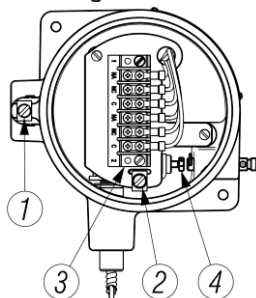

Electrical connections and adjustment screws

- ① Vite di terra esterna
External earth screw
- ② Vite di terra interna
Internal earth screw
- ③ Morsettiera
Terminal block
- ④ Vite di regolazione punto di intervento micro 1 e 2
Calibration screws of microswitch 1 and 2

Particolare del dispositivo di blocco del coperchio.
 Detail of cover's tamper proof device

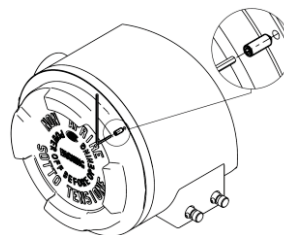

I dati sono impegnativi solo su offerta scritta / Data are binding only on written quotation



ETTTORE CELLA SPA
 A division of the WIKA group

Viale De Gasperi, 48 - I 20010 Bareggio - MILANO - ITALY
 Tel. +39 02 90361146 - Fax +39 02 90361331

PT-C2-12 R10

www.ecellaspa.com

cella@ecellaspa.com

PER ORDINARE precisare i dati:

Codice modello - Campo di taratura - Filettatura attacco bulbo - Filettatura passaggio cavi - Eventuali opz. - Versioni.

TO ORDER specify:

Model code - Setting range - Bulb connection thread - Cable entry thread - Options if any - Versions.

Esempio / Example: **TAGUN - K 2 m - 0/100°C - 1/2-14 NPT-M - 1/2-14 NPT-F**

1	CODICE MODELLO MODEL CODE	TAG	CONSEGNA / DELIVERY STD + 1 SETTIMANA / WEEK													
			CONSEGNA / DELIVERY STD + 2 SETTIMANE / WEEKS													
CARATTERISTICHE / FEATURES																
		TIPO CONTATTI CONTACT TYPE	PORTATE (Carico resistivo) ① ELEC.RATINGS (resistive load)													
				CA / AC	CC / DC											
Serie Series		<table border="1"> <tr><td>UN</td><td>DN</td></tr> <tr><td>US</td><td>DS</td></tr> <tr><td>UO</td><td>DO</td></tr> <tr><td>UG</td><td>DG</td></tr> <tr><td>UR</td><td>---</td></tr> </table>	UN	DN	US	DS	UO	DO	UG	DG	UR	---	Differenziale FISSO FIXED dead band	Contatti argento, in aria Silver contacts, in air	<u>15A 250V</u>	<u>2A 24V</u> 0,5A 125V 0,25A 220V
UN	DN															
US	DS															
UO	DO															
UG	DG															
UR	---															
1.2 Contatti elettrici Electric Contacts		<table border="1"> <tr><td>1 micro SPDT, code U</td></tr> <tr><td>2 micro SPDT, code D</td></tr> </table>	1 micro SPDT, code U	2 micro SPDT, code D	Contatti argento, sigillato in argon Silver contacts, argon sealed T amb -30/+70°C	<u>15A 250V</u>	<u>2A 24V</u> 0,5A 220V									
1 micro SPDT, code U																
2 micro SPDT, code D																
			Contatti dorati, sigillato in argon Gold plated contacts, argon sealed T amb -30/+70°C	<u>1A 125V</u>	<u>0,5A 24V</u>											
			Contatti dorati, in aria Gold plated contacts, in air	<u>1A 125V</u>	<u>0,5A 24V</u>											
			Differenziale REGOLABILE Contatti argento ADJUSTABLE dead band Silver contacts	<u>20A 250V</u>	<u>2A 24V</u> 0,5A 220V											

① Su targa strumento sono riportati solo dati sottolineati.
On instrument nameplate, data underlined only

2	LUNGHEZZA CAPILLARE (solo sensore tipo "C") CAPILLARY LENGTH (Only sensor type "C ")	K [m]	2	4	6	8	10
----------	--	-------	----------	----------	----------	----------	-----------

3	CAMPI di Taratura e lavoro; vedi tabella pagina seguente Setting and working RANGES; see table next page
----------	--

4	ATTACCO BULBO BULB CONNECTION	1/2-14 NPT-M	Opz. Opt.	G1/2A-M, 3/4-14-NPT-M, G3/4A-M
----------	---	---------------------	--------------	--------------------------------

5	PASSAGGIO CAVI CABLE ENTRY	1/2-14 NPT-F	OPZ. OPT.:	3/4-14 NPT-F, Gk1/2-F, Gk3/4-F	Raccordi Adaptors	M20x1,5-F	Pressacavo/ cable gland vedi / see PT-H3-11
----------	--------------------------------------	---------------------	---------------	-----------------------------------	----------------------	-----------	--

6	OPZIONI OPTIONS	Taratura del punto di intervento Set point calibration	Staffa per montaggio su tubo da 2" Yoke for 2" pipe mounting	Bulbo a spirale (campo -30/+70°C) Helical bulb (range -30/+70°C)	Temperatura ambiente -60°C; applicabile a contatti ele. UN, DN, UG, DG, UR Ambient temperature -60°C; applicable to ele. contacts UN, DN, UG, DG, UR	Bulbo diametro 9,5 mm (Y=195, X=135 mm) Bulb diameter 9,5 mm (Y=195, X=135 mm)
----------	---------------------------	---	---	---	---	---

7	VERSIONI SU RICHESTA	NACE ②④	NACE + Off-Shore ②③④	Off-Shore. ③④	Ammonia. ④	Tropical. ④	Geothermal. ④
	VERSIONS ON REQUEST	Ex d GOST R	Ex d INMETRO - CEPEL	Ex d KCS - KOSHA	SIL IEC 61508 micro US, UO only		

② NACE compliance to MR0175 / ISO15156 and to MR0103:
Utilizzare pozzetti termometrici a norma NACE.
③ Off-shore: verniciatura speciale color blue, spessore 200 µm
④ Contatti elettrici consigliati US, DS, UO, DO; ammesso l'uso di UR

② NACE compliance to MR0175 / ISO15156 and to MR0103:
Use thermowells conform to NACE.
③ Off-shore: Special painting blue colour, thickness 200 µm
④ Recommended electrical contacts US, DS, UO, DO; allowed use of UR



ALTA QUALITÀ COSTANTE dal 1897
CONSTANT HIGH QUALITY since 1897

**COMPANY WITH
MANAGEMENT SYSTEM
CERTIFIED BY DNV**
= ISO 9001 =
= ISO 14001 =

3**CAMPI di Taratura, campo di lavoro, temperatura di prova***Setting RANGES, working range, proof temperature*La classificazione del sistema termometrico si basa su **SAMA: CLASSE III B***The classification of the thermal system is based on SAMA: CLASS III B***SAMA:** Scientific Apparatus Makers Association

Campo di taratura <i>setting range</i>	Campo di lavoro <i>working range</i>	(temperatura di prova) <i>(proof temperature)</i>	Differenziale / <i>Dead band</i>		
			Fisso e inferiore a: <i>Fixed and lower than:</i>		Regolabile tra min-max Adjustable between min-max
			1 contact, code UN, US, UO, UG	2 contacts, code DN, DS, DO, DG	1 contact code UR
-30 / +70	-40 / +70	(120)	4,5	4,5	15÷35
0 / +100	-40 / +100	(120)	4,5	4,5	15÷35
0 / +160	-40 / +160	(190)	5	5	18÷35
0 / +250	-40 / +250	(300)	6	6	21÷45
0 / +400	-40 / +400	(500)	10	10	33÷77
0 / +600 ^⑤	-40 / +600	(600)	17	17	50÷115

⑤ Dimensioni bulbo / *Bulb dimension X=102, Y=163*I dati sono impegnativi solo su offerta scritta / *Data are binding only on written quotation*

Your Distributor:
Coulton Instrumentation Ltd
17 Somerford Business Park, Christchurch, BH23 3RU, UK
Tel: +44 1202 480 303 Fax: +44 1202 480 808
E-mail: sales@coulton.com Web: www.coulton.com