

IN-SITU ZIRCONIA OXYGEN ANALYZER

DATA SHEET

ZFK8, ZKM, ZTA

This oxygen analyzer is used to continuously measure oxygen concentration in combustion exhaust gas of industrial boilers or furnaces, and is ideally suited for combustion management and control.

The analyzer system is comprised of the detector and converter coupled together as a complete system. Detector setting configuration includes the detector flow guide tube and detector sensor. The flow guide tube is inserted directly into the gas and directs gas to the sensor for measurement. The converter (ZKM) is comprised of the signal processor, input/output and communications, display and system controls.

The converter is equipped with advanced functionality such as performing the sensor diagnostics and sensor recovery function, so the detector can be used within long term stability.

FEATURES

- Gas sampling device is unnecessary**
For quick response, insert the detector directly into the flue Gas sampling functions such as a gas aspirator and a dehumidifier are not required.
- Easy maintenance**
The sensor equipped with the detector, has unit construction, it is easy to replace.
By separating the detector and the flow guide tube, filter replacement is easy.
- More reliable than sensor diagnosis, sensor recoverable function**
Depending on the concentration of the measurement gas, the power of the sensor might deteriorate. The equipment includes sensor recovery function electronically, checking the deterioration status of the sensor depletion.
Therefore, it has high reliability and long-lasting stability.
- Safe and secure**
System detects thermocouple break for heater control on the sensor side. Safety functions of isolating power supply to the detector or isolating power via external contact input are also.
- Easy operation**
The operation and setting for the converter can be performed interactively, and available as English, Japanese or Chinese for language display.

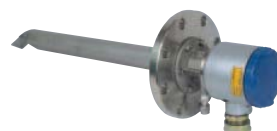

General-use detector
(ZFK8)



High-temperature detector
(ZTA)



<IP66>
Converter (ZKM1)



<IP67>
Converter (ZKM2)

SPECIFICATIONS

General Specifications

- Measuring object:** Oxygen in noncombustible gas
Measuring method: Directly insert type zirconia system
Measuring range: 0 to 2 ... setting range at option 2 in 50 vol% O₂
 (in 1 vol% O₂ steps)
Repeatability: Within $\pm 0.5\%$ FS
Linearity: Within $\pm 2\%$ FS
Response time: Within 4 to 7 sec, for 90% (from calibration gas inlet)
Warmup time: More than 10 min
Analog output: 4 to 20mA DC (allowable load resistance less than 500 Ω) or 0 to 1V DC (output resistance more than 100 Ω)
Power supply: Rated voltage;
 100 to 120V AC (operating voltage 90 to 132V AC)
 200 to 240V AC (operating voltage 190 to 264V AC)
 Rated frequency; 50/60Hz
Power consumption: Maximum 240VA (Detector: approx. 200VA, Converter: approx. 40VA)
 Normal 70VA (Detector: approx. 50VA, Converter: approx. 20VA)

Detector Specifications (ZFK)

Measured gas temperature:

Flow guide tube system; -20 to +600°C (for general-use, corrosive gas)
Ejector system; -20 to +1500°C (for high-temperature gas)
-20 to +800°C (for general-use)

Measured gas pressure:

-3 to +3kPa (-306 to +306mmH₂O)

Flow guide tube:

With or without blow-down nozzle
Flange; JIS5K 65A FF
(JIS5K-80AFF for high particulate gas)
Insertion length; 0.3, 0.5, 0.75, 1m

Ejector (general-use):

Probe for guiding measured gas to detector
Flange; JIS10K 65A RF
Insertion length; 0.5, 0.75, 1, 1.5m (according to customer's specification)

Operating temperature:

-10 to +60°C for Primary detecting element
-5 to +100°C for ejector section
125°C or less at detector flange surface with power applied

Storage temperature:

Sensing element: -20 to +70°C
Ejector: -10 to +100°C

Structure:

Dust/rain-proof structure(IEC IP66 equivalent)

Filter:

Alumina(filtering accuracy 50µm) and quartz paper

Main materials of gas-contacting parts:

Detector; Zirconia, SUS316, platinum
Flow guide tube; SUS304 or SUS316
Ejector (general use); SUS316, SUS304
Ejector; (for high temperature) SiC, SUS316, SUS304

Calibration gas inlet:

φ6mm tube join, φ1/4-inch tube join, or ball valve (as specified)

Reference air inlet (option):

φ6mm tube join or φ1/4-inch tube join (as specified)

Detector mounting:

Horizontal plane ±45°, ambient surrounding air should be clean.

Outer dimensions: (L × max. dia.) 210mm × 100mm (detector)

Mass (approx.) {weight}:

Detector; 1.6kg
Ejector; 15kg (insertion length 1m)
Flow guide tube (general-use, 1m); 5kg

Finish color:

Silver and SUS metallic color

Ejector air inlet flow rate:

5 to 10 L/min

Calibration gas flow:

1.5 to 2 L/min

Blowdown air inlet pressure:

200 to 300kPa {2 to 3 kgf/cm²}

Ejector exhaust gas processing:

Into furnace, returned to flue

Heater temperature drop alarm output (ejector):

Alarm output when below 100°C Mechanical thermostat

N.O. (1a) contact, 200V AC, 2A

Converter specification (ZKM)

Concentration value indication:

Digital indication in 4 digits

Contact output signal:

(1) Contact specification; 6 points, 1a 250V AC/3A or 30V DC/3A
(2) Contact function;

- Under maintenance
- Under blowdown Note3)
- Span calibration gas valve
- Zero calibration gas valve
- Instrument anomalies Note1)
- Alarm Note2)

Note1) The following Instrument errors (1) Thermocouples break (2) Sensor break (3) Temperature fault (4) Calibration fault (5) Zero/span adjustment fault (6) Output error turn the contact-ON

Note2) Alarm selects just one as mentioned below (1) High (2) Low (3) Upper and Lower (4) High-high (5) Low-low, it turns ON while operating.

Note3) Under blow down is available in case of option, and it turns ON while operating.

Contact input signal:

(1) Contact specification; 3points (the following option) ON; 0V (10mA or less), OFF; 5V

(2) Contact function;

- External hold
- Calculation reset
- Heater OFF
- Blow down (option)
- Inhibition of calibration
- Calibration start
- Range change

Calibration method:

- (a) Manual calibration with key operation
- (b) Auto. calibration (option)
Calibration cycle; 00 day 00 hour to 99 days 23 hours
- (c) All calibration

Calibration gas:

- Available range settings
Zero gas; 0.010 to 25.00% O₂
Span gas; 0.010 to 50.00% O₂
- Recommended calibration gas concentration
Zero gas; 0.25 to 2.0% O₂
Span gas; 20.6 to 21.0% O₂
(oxygen concentration in the air)

Blowdown:

A function for blowing out with compressed air dust that has deposited in the flow guide tube. Blowdown can be performed for a predetermined time and at predetermined intervals.

(option)

Blowdown cycle; 00 hour 00 minute to 99 hours 59 minutes
Blowdown time; 0 minute 00 second to 0 minutes 999 seconds

Output signal hold:

Output signal is held during calibration, processing recoverable sensor, processing diagnosis of sensor, warm-up, PID auto tuning, under set up maintenance mode "available" and blowdown. The hold function can also be released.

Valve and Flow meter (option):

Selects zero or span gas during manual zero or span calibration. Mounted on the side of the converter.

Communication function:

RS232C (MODBUS) standard specification
RS485 (MODBUS) (option)

Combustion efficiency display (option):

When you select this display, "rich mode display" will be simultaneously displayed. This function calculates and displays combustion efficiency from oxygen concentration and measured gas temperature.
Thermocouple (R) is required for temperature measurement.

Operating temperature:

-20 to +55°C

Operating humidity:

95% RH or less, non condensing

Storage temperature:

-30 to +70°C

Storage humidity:

95% RH or less, non condensing

Construction:

Dust-proof, rainproof construction

(corresponding to IP66 or IP67 of IEC)

Material:

Aluminum case

Outer dimensions (H x W x D):

170 X 159 X 70mm (IP66, Bench type)

220 X 230 X 95mm (IP67)

182 X 163.5 X 70.6mm (Bench type)

Mass {weight}:

IP66: Approx. 2kg (excluding cable and detector)

IP67: Approx. 4.5kg (excluding cable and detector)

Finish color:

IP66: Case: Silver
Cover: Pantone Cool Gray 1C-F

IP67: Munsell 6PB 3.5/10.5 (blue)
Cover: Silver (case)

Mounting method:

Mounted flush on panel or on pipe

CODE SYMBOLS

(Detector)

ZFK		4	5	6	7	8	9	10	11	12	13	14	15	16	Description
8	R					5								1	Cal. gas inlet
														2	For φ6mm tube (SUS)
														3	For φ1/4 inch tube (SUS)
															Ball valve
														1	Power supply
														3	100 to 120VAC 50/60Hz
															200 to 240VAC 50/60Hz CE
															Flow guide tube
															flange application length
															None
															0Y0
															5A3
															SUS304 general use 300mm
															5A5
															SUS304 general use 500mm
															5A7
															SUS304 general use 750mm
															5A1
															SUS304 general use 1000mm
															5B3
															SUS316 for corrosive gas 300mm
															5B5
															SUS316 for corrosive gas 500mm
															5B7
															SUS316 for corrosive gas 750mm
															5B1
															SUS316 for corrosive gas 1000mm
															5C3
															SUS316 with blow-down nozzle 300mm
															5C5
															SUS316 with blow-down nozzle 500mm
															5C7
															SUS316 with blow-down nozzle 750mm
															5C1
															SUS316 with blow-down nozzle 1000mm
															6D3
															SUS316 for high particulate 300mm
															6D5
															SUS316 for high particulate 500mm
															6D7
															SUS316 for high particulate 750mm
															6D1
															SUS316 for high particulate 1000mm
															6E3
															SUS316 for high particulate with 300mm
															6E5
															SUS316 for high particulate with 500mm
															6E7
															SUS316 for high particulate with 750mm
															6E1
															SUS316 for high particulate with 1000mm
															ZZZ
															Protection cover
															Y
															Without
															A
															With
															Reference air inlet
															Y
															Non
															A
															For φ6mm tube (SUS)
															B
															For φ1/4 inch tube (SUS)
															Filter spec.
															1
															Standard
															Instruction manual language
															J
															Japanese
															E
															English
															C
															Chinese
															Specification name plate
															1
															Standard (100 to 120V AC 50/60Hz)
															2
															Standard (200 to 240V AC 50/60Hz)

Electrical Safety:

Overvoltage category
; **II power supply input**
; **I relay interfaces**
(IEC1010-1)

External overcurrent protective device
; **10A**

Equipment interfaces are safety separated (SELV)

The product conforms to the requirements of the Electromagnetic compatibility Directive 89/336/EEC as detailed within the technical construction file number TZ734575. The applicable standards used to demonstrate compliance are :

EN 55011 : 1992 CLASSA Conducted and Radiated emissions

EN 50082-1 : 1992 Radiated immunity, ESD and FBT

(Replacement Detector element)

Power supply	Code symbols
100 to 120V AC	ZFK8YY15-0Y0YY-0YY
200 to 240V AC	ZFK8YY35-0Y0YY-0YY



CONFIGURATION

Flow guide tube system (with valve)

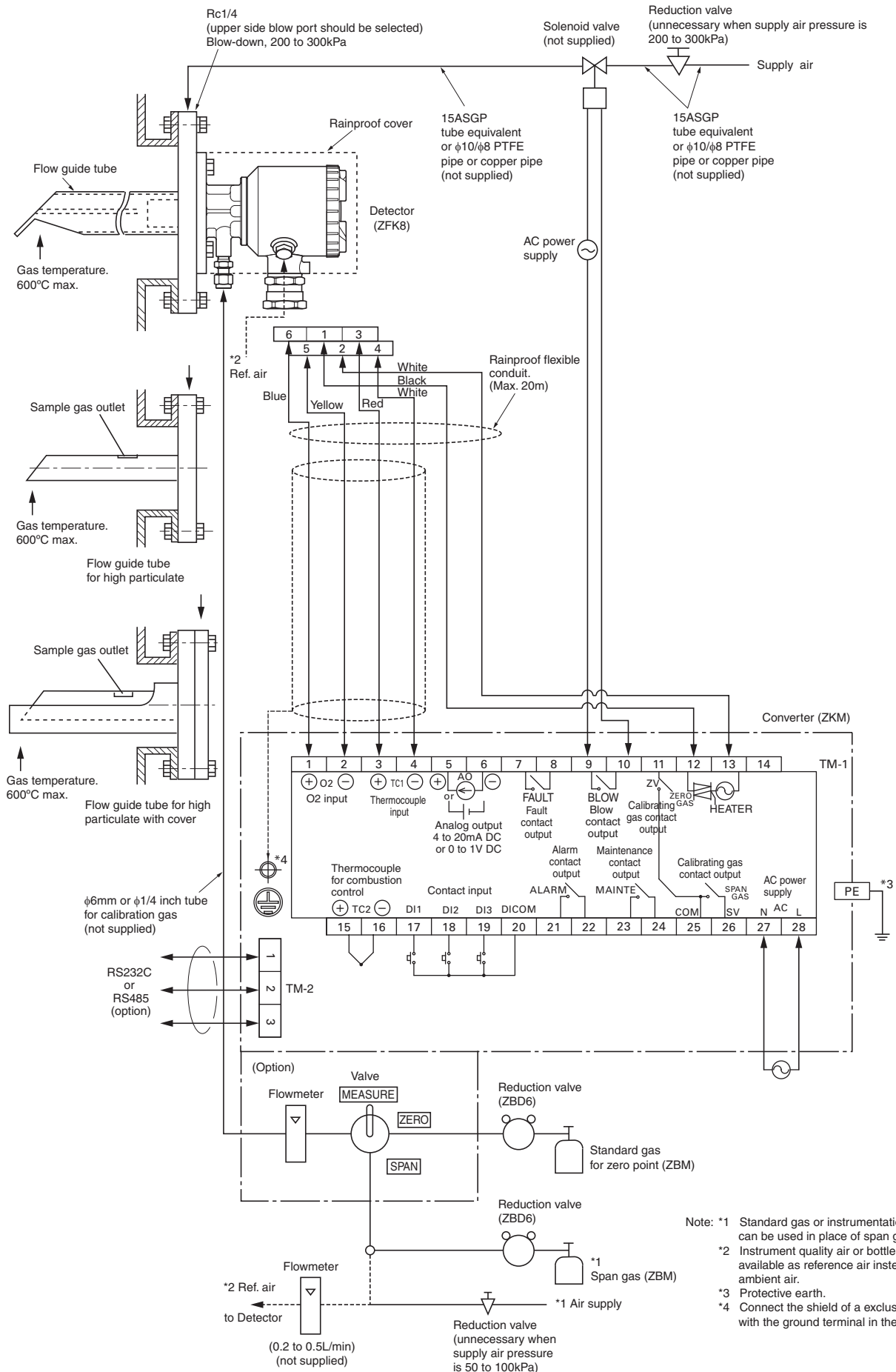

Flow guide tube system

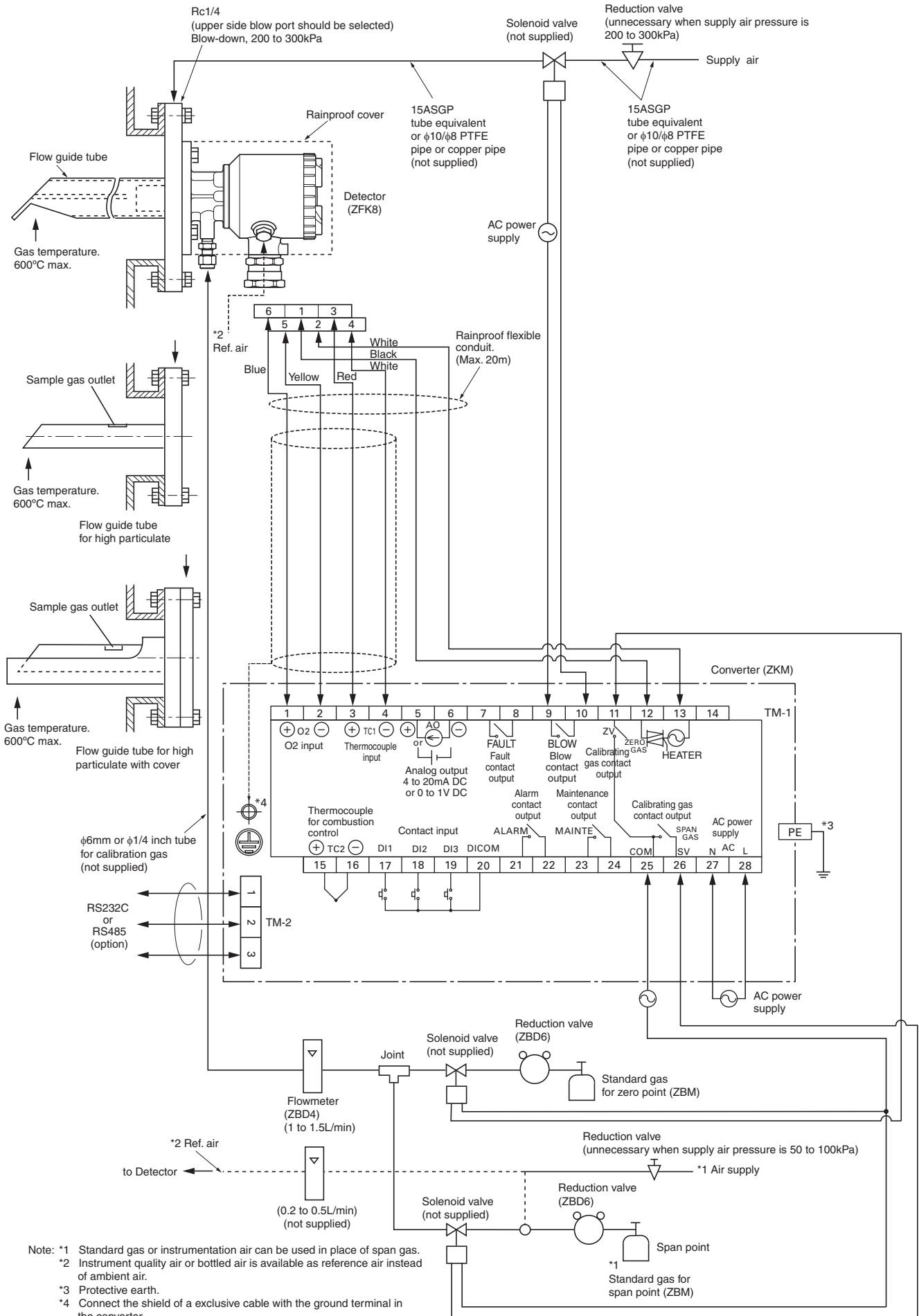

Ejector system (with valve)

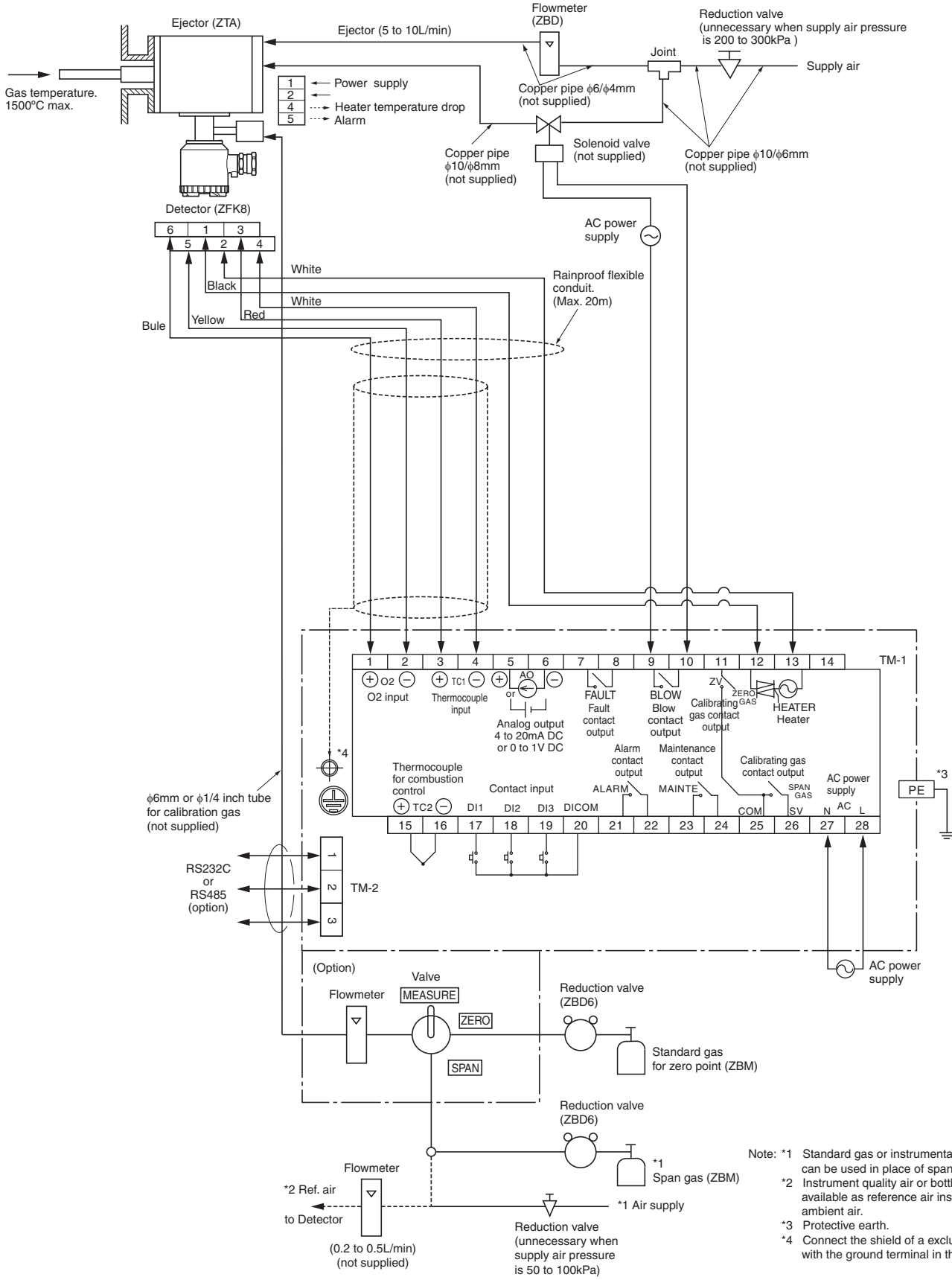

- Note: *1 Standard gas or instrumentation air can be used in place of span gas.
 *2 Instrument quality air or bottled air is available as reference air instead of ambient air.
 *3 Protective earth.
 *4 Connect the shield of a exclusive cable with the ground terminal in the converter.

Ejector system

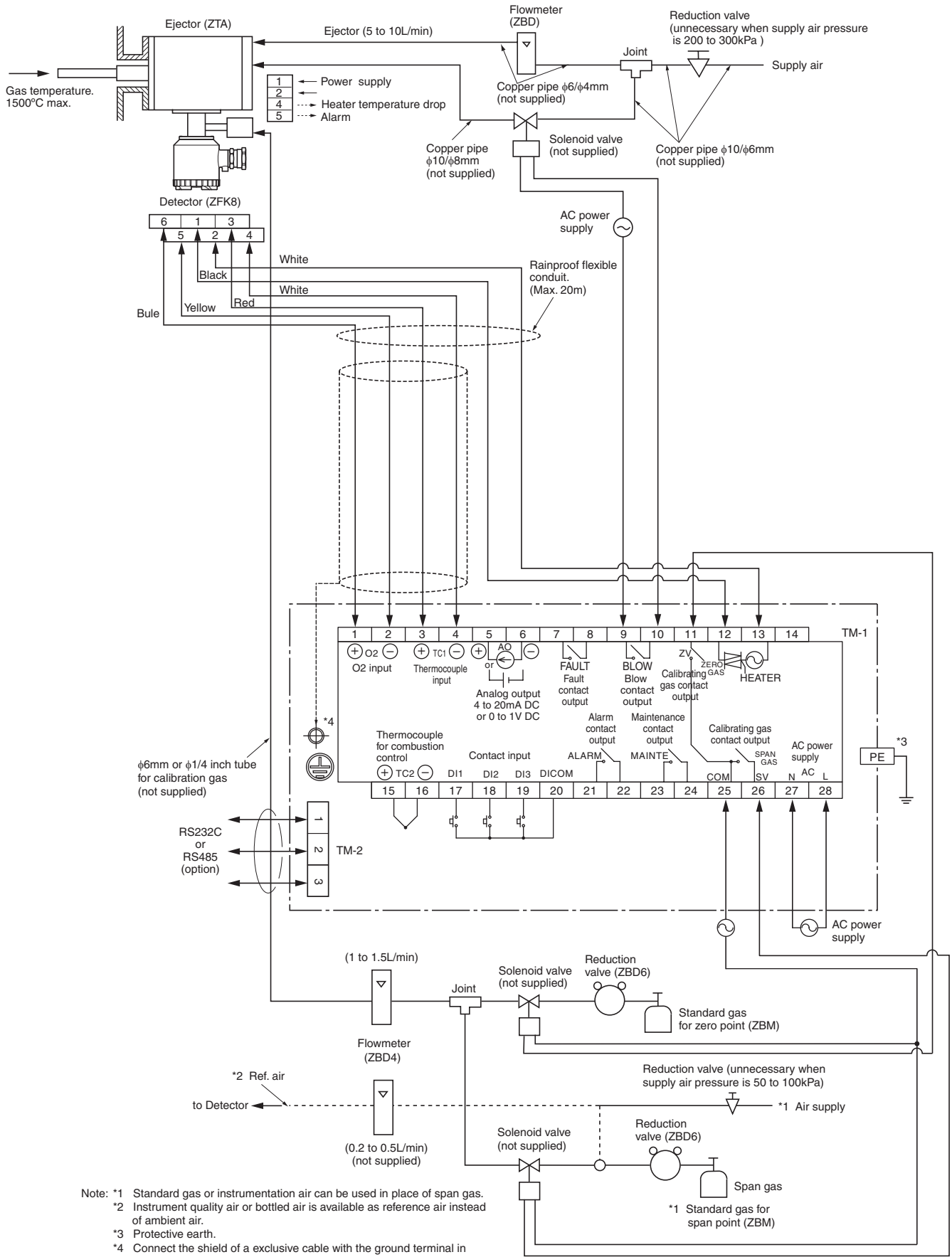

DEVICE CONFIGURATION

The device to be combined differ according to the conditions of the gas to be measured. Select the devices to be combined with reference to the following table.

Application	Temperature	Gas Flow	Measured gas			Device configuration		
			DUST	Protection cover	Note	Detector type	Converter type	Ejector type
General-use (boiler)	600°C or less	5 to 20m/s	Less than 0.2g/Nm ³	—	Fuel; gas, oil	ZFK8R□□5-□A5□□-1□	ZKM	—
			Less than 10g/Nm ³	—	Fuel: coal with blow down	ZFK8R□□5-□C5□□-1□	ZKM	—
For corrosive gas (refuse incinerator)	600°C or less	5 to 20m/s	Less than 1g/Nm ³	—	Included low moisture	ZFK8R□□5-□B5□□-2□	ZKM	—
			Less than 10g/Nm ³	—	Included low moisture with blow down	ZFK8R□□5-□C5□□-2□	ZKM	—
			Less than 25g/Nm ³	no	Included low moisture with blow down	ZFK8R□□5-□D6□□-2□	ZKM	—
			Less than 25g/Nm ³	yes	Included high moisture with blow down	ZFK8R□□5-□E6□□-2□	ZKM	—
General-use (boiler)	800°C or less	Less than 1m/s	Less than 1g/Nm ³	—	SUS316 tube with blow down	ZFK8R□□5-0Y0□□-1□	ZKM	ZTA2
	1500°C or less	Less than 1m/s	Less than 1g/Nm ³	—	SIC tube with blow down	ZFK8R□□5-0Y0□□-1□	ZKM	ZTA1

Note (1) Dust volume is approximate value.

(2) Instrument quality air or bottled air is available as reference air by selecting detector with reference air inlet.

OUTLINE DIAGRAM (Unit:mm)

Detector (ZFK8)

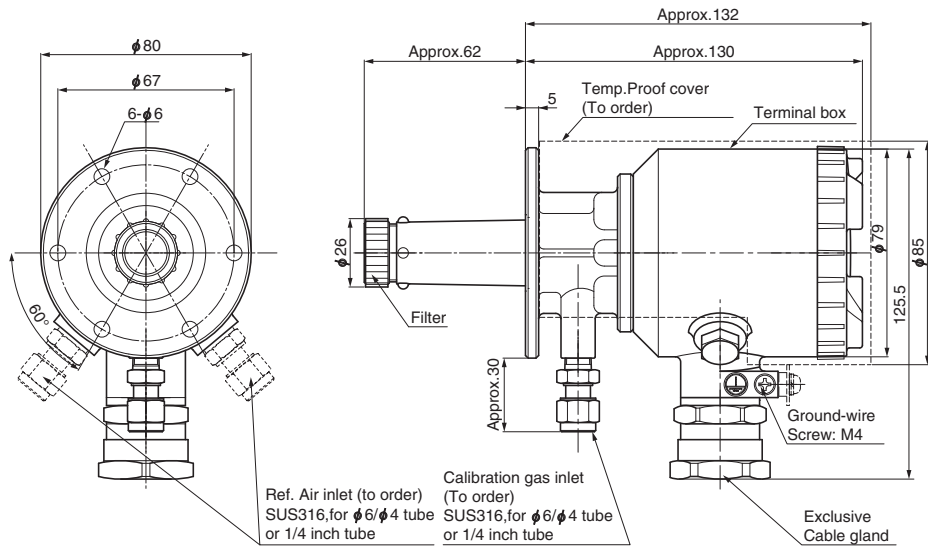

EXTERNAL CONNECTION DIAGRAM

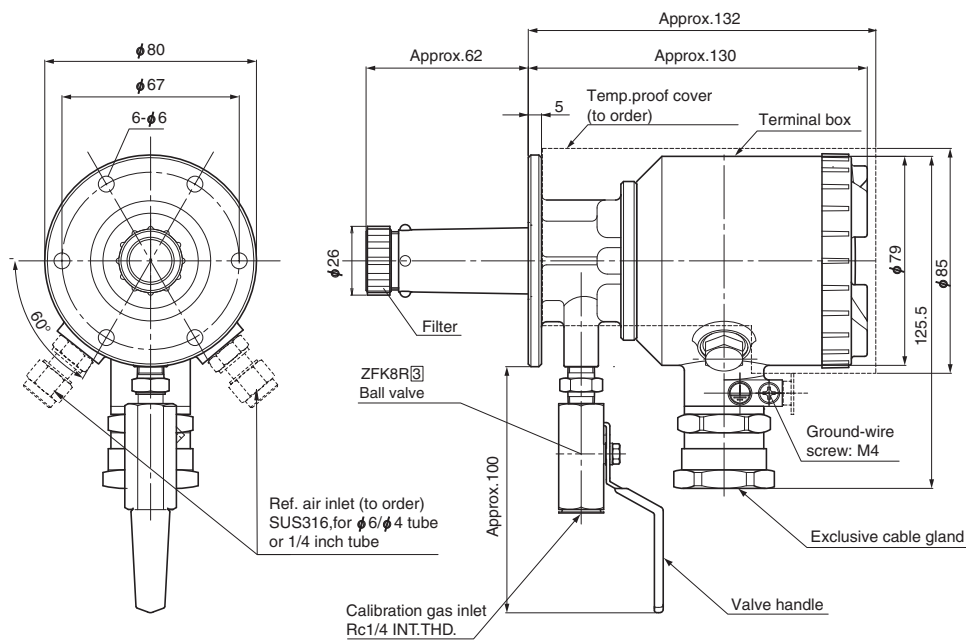
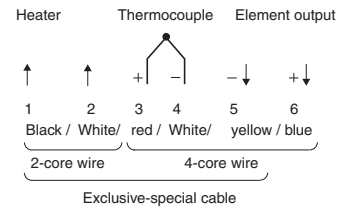

Sensor unit (ZFK8YY)

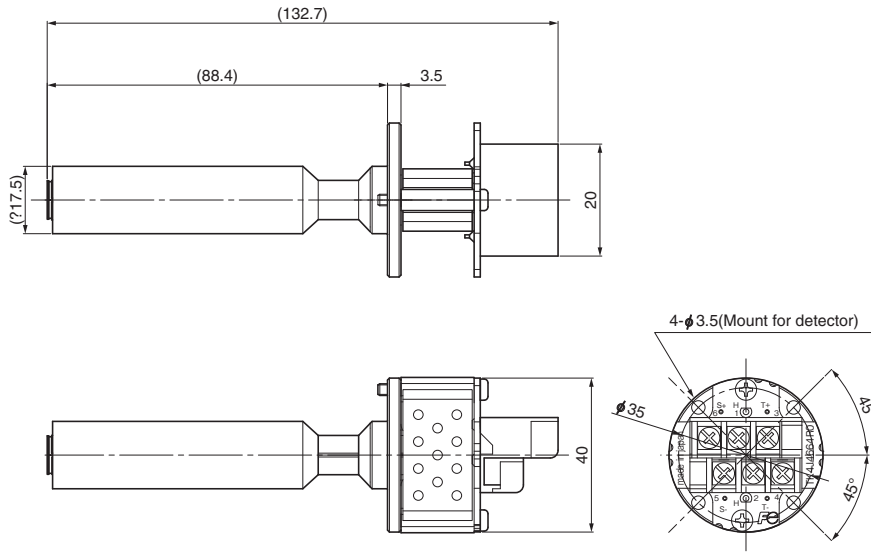

Flow guide tube

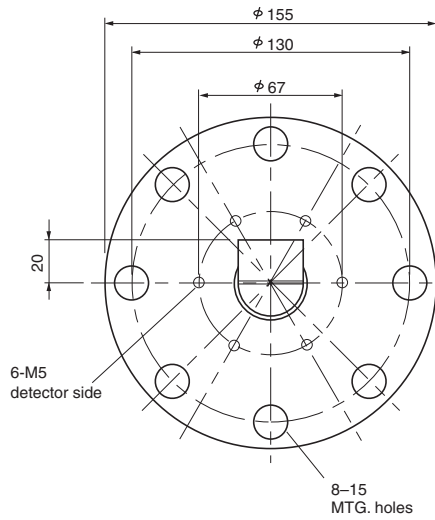
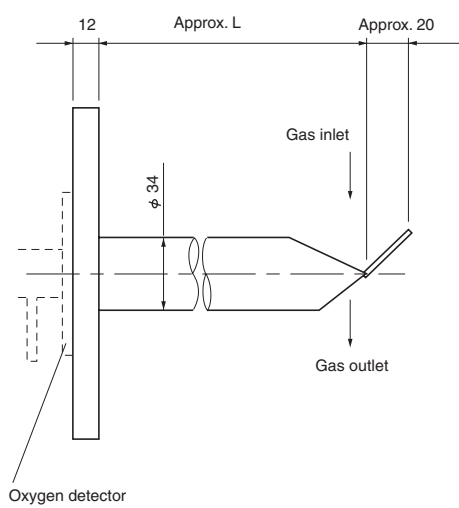

ZFK8R□□5-5A□
□
□
□
□

Code 11th	3	5	7	1	Z
L (m)	0.3	0.5	0.75	1.0	L=
MASS Approx.(kg)	2.7	3.3	4.1	4.8	(to order)

Flow guide tube (with blow-down nozzle)

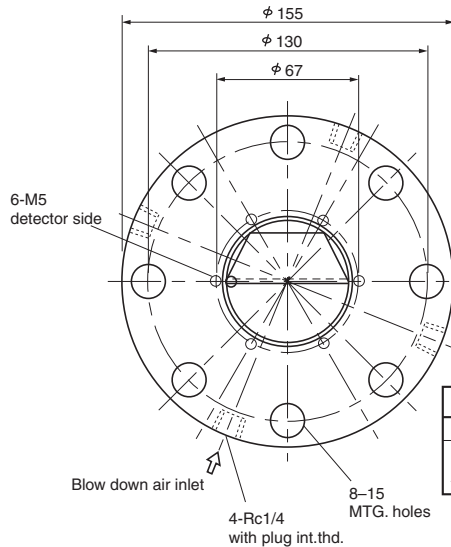
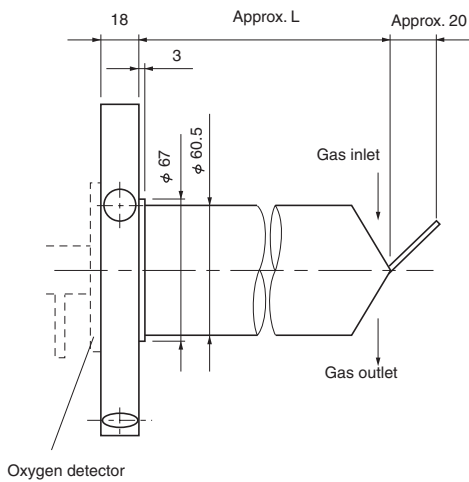

ZFK8R□□5-5C□
□
□
□
□

Code 11th	3	5	7	1	Z
L (m)	0.3	0.5	0.75	1.0	L=
Mass Approx.(kg)	3.0	3.8	4.8	5.7	(to order)

Flow guide tube (for corrosive gas)

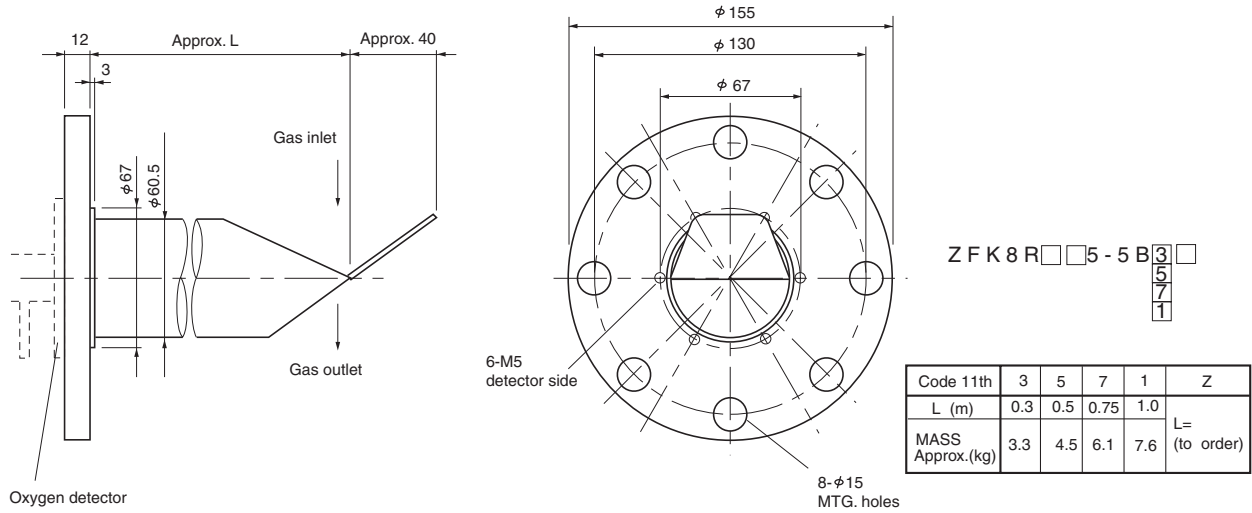

Ejector (ZTA)

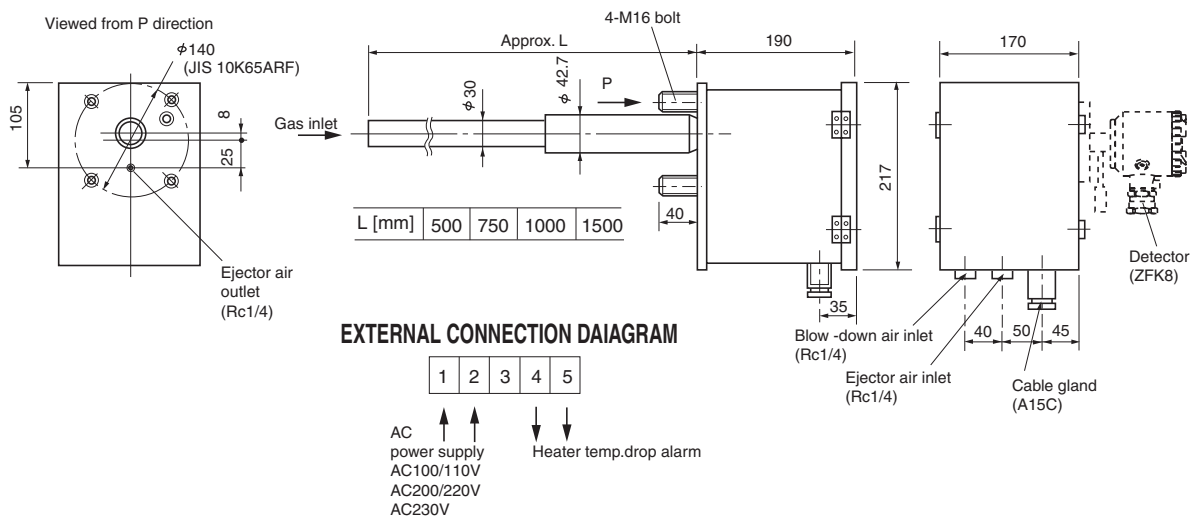

Converter (ZKM1)

<IP66>

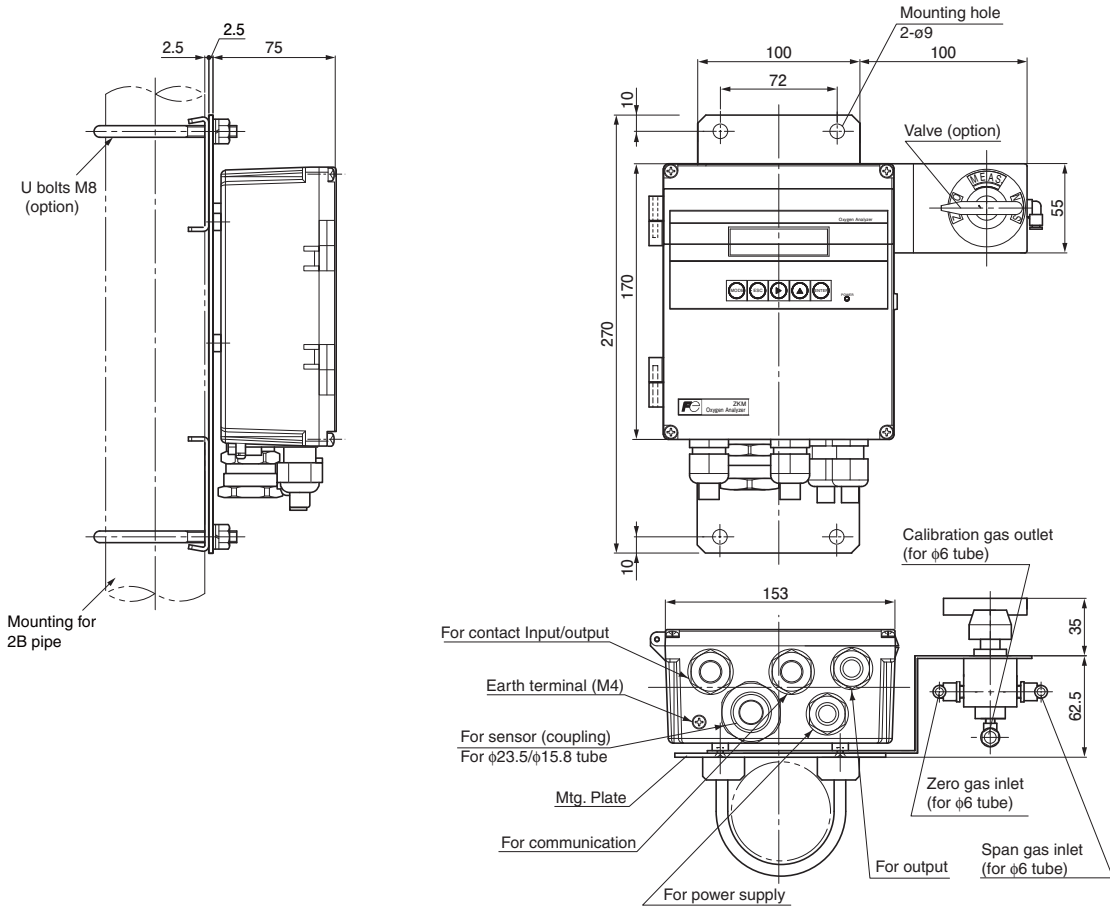

Converter (ZKM2)

<IP67>

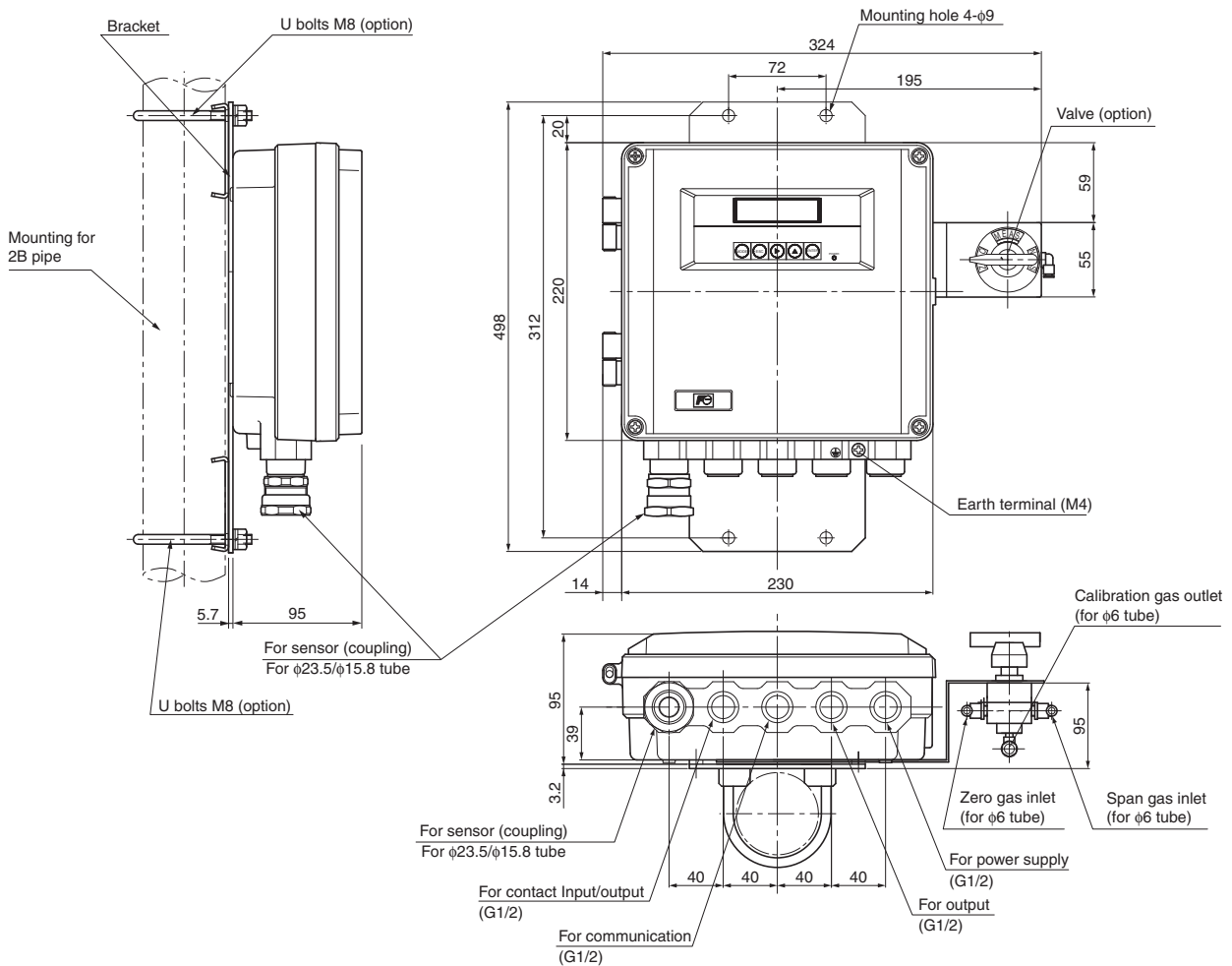

Converter (ZKM3)
<Bench type>

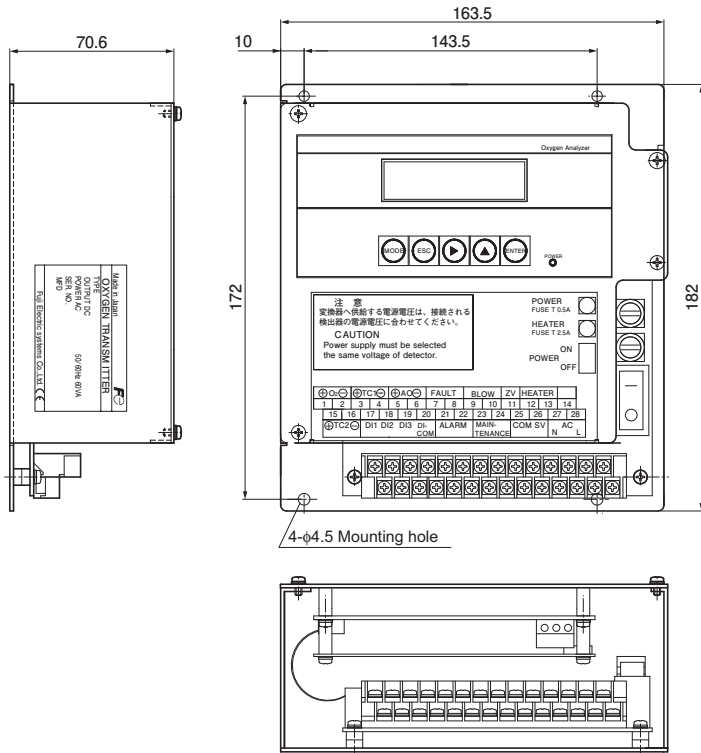

EXTERNAL TERMINAL (TM1) / Terminal M3

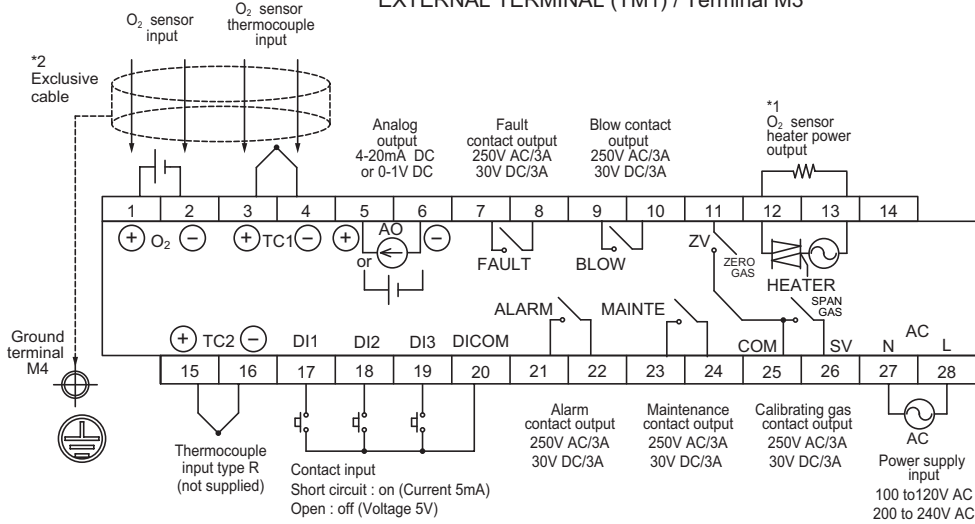

COMMUNICATION TERMINAL (TM2) /INSERTION TERMINAL

	Terminal number			Remarks
	1	2	3	
RS232C	TXD	RXD	GND	Standard
RS485	TRX+	TRX-	GND	Option

- Note 1) The heater power supply is the same as the converter power supply.
- Note 2) Be sure to connect the shield of the cable to the ground in the main body.

⚠ Caution on Safety

*Before using this product, be sure to read its instruction manual in advance.

Fuji Electric

Your distributor:

Coulton Instrumentation Ltd

17 Somerford Business Park, Christchurch, BH23 3RU, UK

Tel: +44 1202 480 303

E-mail: sales@coulton.com

Web: www.coulton.com