

PORTABLE TYPE ULTRASONIC FLOWMETER (PORTAFLOW-C)

DATA SHEET

FSC, FSD

PORTAFLOW-C is a portable type ultrasonic flowmeter utilizing the transit time measuring method, using a clamp-on type detector.

It is a compact and lightweight instrument incorporating the latest electronics and digital signal processing technologies, realizing high performance and easy operation.

FEATURES

- 1. Compact and lightweight**
The adoption of the latest electronics and digital signal processing technologies has reduced the size and weight of the flow transmitter by 30% and 30%, respectively, in comparison with the Fuji conventional portable flowmeter (Model FSC). (in comparison to our existing model)
- 2. Battery operation**
The flowmeter is designed for 12 hours of continuous operation via built-in battery which is rechargeable in 3 hours with the exclusive power adapter.
- 3. Full variety of detectors**
The flowmeter is suitable for various types of detectors applicable for small to large diameter pipe (pipe inner diameter $\phi 13$ to $\phi 6000\text{mm}$) and low to high temperature (-40 to $+200^\circ\text{C}$).
- 4. High accuracy and high-speed response**
The flowmeter is designed for high accuracy ($\pm 1.0\%$).
Response time is within 1 second.
- 5. Improved anti-bubble characteristic**
Anti-bubble characteristic is greatly improved by digital signal processing.
- 6. Excellent performance and easy operation**
Large graphic LCD that is outside but easy to read.
Minimum number of function keys are used for page selection, allowing easy setting.
While battery is working, the flowmeter is water resistant and tolerates exposure to rain.
- 7. Large capacity storage by SD memory card**
Measured data is periodically stored in SD memory card. For example, in the case of 256MB (option), it can be saved about 1 year measurement date (In case of saving period 30 seconds, 14 kinds of saved data). Available up to 8MB.
- 8. Serial communication**
Use of a USB port allows easy connection to a personal computer. Measured data collection panel and Loader software for PC (standard) which is available for display and change of parameter (site setting) are prepared.
- 9. Heat quantity (calorie) measurement**
Heat quantity (calorie) may be measured by temperature input, making energy management easy for cooling and heating.



Flow transmitter (FSC)



Detector for transit time (FSD)

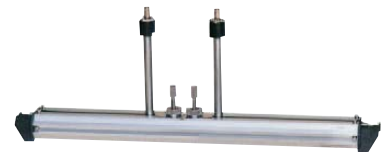

Detector for high-temperature (FSD)

- 10. Graphic printer connection (option)**
Easy recording with the Integral type printer.
- 11. Flow velocity profile measurement (option)**
Flow profile may be observed in real time.

SPECIFICATIONS

Measuring objects

Measurement fluid:

Uniform liquid in which ultrasonic waves can propagate.

Turbidity of fluid: 10000 mg/L or less

State of fluid: Well-developed turbulent or laminar flow in a filled pipe.

Fluid temperature: -40 to $+200^\circ\text{C}$

Measuring range: $0 \cdots \pm 0.3$ to $\pm 32\text{m/s}$

Piping conditions

Applicable piping material:

Select from carbon steel, stainless steel, cast iron, PVC, FRP, copper, aluminum, acrylic or material of known sound velocity.

Pipe size:

Flow rate measurement
 $\phi 13$ to $\phi 6000\text{mm}$

Flow velocity profile measurement
 $\phi 40$ to $\phi 1000\text{mm}$

Lining material: Select from no lining, tar epoxy, mortar, rubber, Teflon, pyrex glass or material of known sound velocity.
 Note) No gap allowed between the lining and the pipe.

Straight pipe length:
 10D or more upstream and 5D or more downstream (D: internal pipe diameter)
 Refer to Japan Electric Measuring Instruments Manufactures' Association's standard JEMIS-032 for details.

Performance specifications

Accuracy rating:

Pipe inner diameter	Flow velocity range	Accuracy
φ13 to φ50mm	2 to 32m/s	±1.5% of rate
	0 to 2m/s	±0.03m/s
φ50 to φ300mm	2 to 32m/s	±1.0% of rate
	0 to 2m/s	±0.02m/s
φ300 to φ6000mm	1 to 32m/s	±1.0% of rate
	0 to 1m/s	±0.01m/s

Note) Reference conditions are based on JEMIS-032.

Flow transmitter (Type: FSC)

Power supply: Built-in battery or AC power adapter
 Built-in battery: Exclusive lithium button battery (5000m Ah)
 Continuous operation time, approx. 12 hours (without printer, back light OFF, output current not used and at normal ambient temperature (20°C))
 Recharging time, approx. 3 hours (power adapter used)
 Recharging temperature range: 0 to +40°C
 Power consumption: Min. 3W and Max. 16W
 The consumption varies depending on the use conditions.

Power adapter: Exclusive power adapter 90V to 264V AC (50/60Hz), 70VA or less.

LCD: Semi-transmissive color graphic display
 240 × 320 (with back light)
 Measurement value (instantaneous flow rate, integrated flow rate) and various settings are displayed.
 Excellent visibility even outdoors in direct sunlight.

LED display: Status display when using AC power adapter.
 DC IN (green): Power supply status
 CHARGE (red): Battery charging underway

Operation keypad:
 11 buttons
 (ON, OFF, ENT, ESC, MENU, △, ▽, ◀, ▶, LIGHT, PRINT)

Power failure backup:
 Measurement value is backed up by nonvolatile memory.
 Clock backup with lithium battery (effective term, 10 years or more)

Response time: 1 second

Analog output signals:
 4 to 20mA DC, one point (load resistance, 600Ω or less)
 Instantaneous velocity, instantaneous flow rate or heat quantity (calorie) after scaling.

Analog input signal:
 4 to 20mA DC, one point (input resistance, 200Ω or less)
 4 to 20mA DC, one point (input resistance, 200Ω or less)
 or 1 to 5V DC, one point
 Used to input temperature for heat quantity measurement, etc.

Total 2 points

SD memory card: Used for data logger function and recording screen data.
 Available up to 8GB (Option256MB)
 Compliant media
 • SD memory card: speed class 2, 4, 6
 • SDHC memory card: speed class 4, 6
 Format
 • FAT16: 64MB to 2GB
 • FAT32: 4GB, 8GB
 Otherwise, reading and saving are impossible.
 File format
 • Date logger: CSV file
 • Screen date: Bit map file

Serial communication:
 USB port (device* compatible):
 Mini B receptacle
 Connectable number of Mini B receptacles:
 1 unit
 Transmission distance: 3m max.
 Transmission speed: 500kbps
 Data:
 Instantaneous velocity, instantaneous flow rate, total value, heat quantity (calorie) value, error information, logger data, etc.
 * Device: Connected plug from PC

Printer (option): To be mounted on top of transmitter unit
 Thermal line dot printing
 Note) When the Chinese display is selected, printing is made in kanji characters.

Ambient temperature:
 - 10 to +55°C (Without printer)
 - 10 to +45°C (With printer)

Ambient humidity: 90%RH or less
Type of enclosure: IP64 (Without printer)
Enclosure case: Plastic case
Outer dimensions: H210 × W120 × D65mm (Without printer)
 H320 × W120 × D65mm (With printer)
Weight: 1.0kg (Without printer)
 1.2kg (With printer)

Various functions

Display language: Selectable from Japanese, English, German, French, Spanish or Chinese (switchable by key operation).

Clock display function:
 Time (year, month, day, hour, minute) display (configurable)
 Monthly error: about 1 minutes at normal temperature (20°C).

Instantaneous value display function:

Instantaneous velocity, instantaneous flow rate display (The flow in reverse direction is displayed with minus “-.”)
 Numeric value: 10 digits (decimal point equals 1 digit)
 Unit: Metric/English system selectable
 Metric system
 Velocity: m/s
 Flow rate: L/s, L/min, L/h, L/d, kL/d, ML/d, m³/s, m³/min, m³/h, m³/d, km³/d, Mm³/d, BBL/s, BBL/min, BBL/h, BBL/d, kBBL/d, MBBL/d
 English system
 Velocity: ft/s
 Flow rate: gal/s, gal/min, gal/h, gal/d, kgal/d, Mgal/d, ft³/s, ft³/min, ft³/h, ft³/d, kft³/d, Mft³/d, BBL/s, BBL/min, BBL/h, BBL/d, kBBL/d, MBBL/d

Total value display function:

Display of forward or reverse total (reverse is displayed as minus)
 Numeric value: 10 digits (decimal point is corresponding to 1 digit)
 Unit: Metric/English system selectable
 Metric system
 Flow rate total: mL, L, m³, km³, Mm³, mBBL, BBL, kBBL
 English system
 Flow rate total: gal, kgal, ft³, kft³, Mft³, mBBL, BBL, kBBL, ACRE-ft

Consumed heat quantity (calorie) display function:

Display of consumed heating medium
 Metric system
 Heat flow: MJ/h, GJ/h
 Total heat quantity: MJ, GJ
 English system
 Heat flow: MJ/h, GJ/h, BTU/h, kBTU/h, MBTU/h, kWh, MWh
 Total heat quantity:
 MJ, GJ, BTU, kBTU, MBTU, kW, MWh
 J : Joule
 BTU : British thermal unit
 W : Watt

Computation function of consumed heat quantity (calorie):

This function calculates the heat quantity received and sent with liquid (water) in cooling and heating.

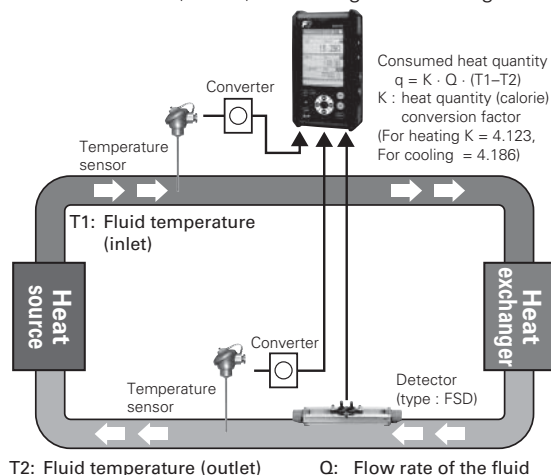

Temperature display function:

Fluid temperature be displayed by current input from temperature transmitter.
 Metric system
 Temperature unit: °C or K
 English system
 Temperature unit: F or K

Site data storage function:

Max. 32 locations (sites) data (pipe size, material, fluid type and etc) can be stored into built-in non-volatile memory.

Damping:

0 to 100sec (every 0.1sec) configurable for analog output and velocity/flow rate display

Low flow cut:

Equivalent to 0 to 5m/s

Output setting function:

Current output scaling, output type, burnout setting and calibration

Serial communication function:

Instantaneous velocity, instantaneous flow rate, total value, heat flow, error information, received waveform, analog input, velocity profile data, logger data, etc. may be downloaded to personal computer.

Logger function:

Instantaneous velocity, instantaneous flow rate, total value, heat flow, error information, received waveform, analog input, velocity profile data can be saved in a SD memory card.

Waveform display function:

Bi-directional received waveforms may be displayed.

Graph display function:

Flow rate trend graph may be displayed.

Printing function (option):

Hard copy output of a screen
 Periodic printing (type: text, graph)
 Logger data (type: text, graph)

Flow velocity profile measurement (option):

Flow velocity profile may be observed in real time using the exclusive detector (option).
 (Refer to page 5 for details.)

Detector (Type: FSD)

Type of detector:

Kind	Type	Internal pipe diameter (mm)	Fluid temperature
Small diameter	FSD22	φ13 to φ100	-40 to 100°C
Small type	FSD12	φ50 to φ400	-40 to 100°C
Middle type	FSD41	φ200 to φ1200	-40 to 80°C
Large type	FSD51	φ200 to φ6000	-40 to 80°C
High temperature	FSD32	φ50 to φ400	-40 to 200°C

Mounting method:

Mounting on outside of pipe

Sensor mounting method:

V or Z method

Signal cable:

Exclusive coaxial cable

Standard 5m (included with FSD41, 51 and FSD32)

Method for connection:

- Flow transmitter side
- Exclusive connector
- Detector side
- Large/middle type: Screw terminal
- Others: BNC connector

Ambient temperature: -20 to +60°C

Ambient humidity: Large/middle type sensor: 100%RH or less

Others: 90%RH or less

Type of enclosure:

- Large/middle type sensor: IP67
- Others: IP52

Material and mounting belt/wire:

Kind	Type	Sensor case	Mounting bracket	Mounting belt /wire
Small diameter	FSD22	Plastic	Aluminum alloy + Plastic	Plastic cloth belt
Small type	FSD12	Plastic	Aluminum alloy + Plastic	Plastic cloth belt
Middle type	FSD41	Plastic	SUS304	Stainless wire
Large type	FSD51	Plastic	--	Stainless wire
High temperature	FSD32	SUS304	Aluminum alloy + SUS304	Stainless belt

Extension cable (option):

Extended when the length of the detector signal cable is not sufficient.
Length: 10m, 50m

MEASURING PRINCIPLE

With ultrasonic pulses propagated diagonally between the upstream and downstream sensors, flow rate is measured by detecting the time difference obtained by the flow of fluid.

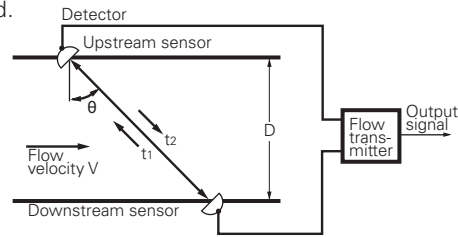

MOUNTING OF DETECTOR

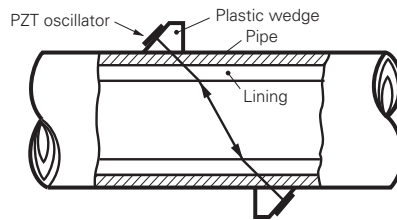

CONFIGURATION DIAGRAM

(1) When V method is used for mounting

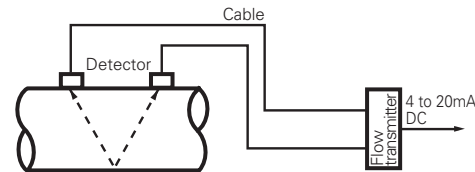

(2) When Z method is used for mounting

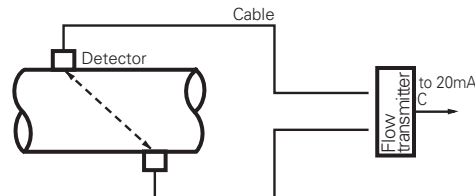

DETECTOR SELECTION GUIDE

Type (Name)	Fluid temperature [°C]	Mounting method	Inner diameter of piping ø (mm)										
			13	25	50	100	200	250	300	400	1000	3000	6000
FSD22 (Small diameter)	-40 to 100	V	*2) 13 [] 100										
FSD12 (Small type)	-40 to 100	V	50 [] 300										
		Z *1)	150 [] 400										
FSD41 (Middle type)	-40 to 80	V	200 [] 600										
		Z	400 [] 1200										
FSD51 (Large type)	-40 to 80	V	200 [] 3000										
		Z	200 [] 6000										
FSD32 (High-temperature)	-40 to 200	V	50 [] 250										
		Z *1)	150 [] 400										

*1) When FSD12 or FSD32 is mounted using the Z-size method, guide rail (option) is required additionally.

*2) For the pipe inner diameter of ø13mm, the sensor mounting dimension may be 0.0mm or less depending on pipe material and thickness. When the sensor mounting dimension is 0.0mm or less, measurement error is about 2 to 5%.

<Description of the table>

It shows pipe thickness of each material that the sensor mounting size is to be 0.0mm, when fixing a pipe. If the fluid is the one other than water, and if the sound velocity of fluid is faster than the one of water, the sensor mounting size is to be 0.0mm or more.

Required min. pipe thickness (fluid: water) (Unit: mm)			
Steel pipe	2.15 or more	FRP	3.21 or more
Stainless pipe	1.87 or more	Ductile cast iron	2.15 or more
PVC pipe	3.69 or more	PEEK	3.69 or more
Copper pipe	3.82 or more	PVDF	3.69 or more
Cast-iron pipe	2.98 or more	Acrylic pipe	2.90 or more
Aluminum pipe	1.99 or more	Polypropylene	3.69 or more

FLOW VELOCITY PROFILE DISPLAY FUNCTION (OPTION)

Flow velocity profile can be observed in real time using the dedicated detector from the outside. It is specifiable by the code symbol of flow transmitter.

APPLICATION

Pulse Doppler method is applicable to observe flow velocity profile in real time, display the flow status in the pipe, and decide the appropriate measurement location. Also, it can be used for diagnosis of flow and laboratory test.

SPECIFICATIONS

Measuring fluid: Uniform liquid in which ultrasonic waves can propagate.

Turbidity of fluid: Axisymmetric flow in a filled pipe.

Fluid temperature:
 -40 to +100°C (FSDP2)
 -40 to +80°C (FSDP1, FSDP0)

Air bubble quantity:
 0.02 to 15Vol% (Velocity is 1m/s)

Pipe size:
 Small type sensor : $\phi 40$ to $\phi 200$ mm
 Middle type sensor : $\phi 100$ to $\phi 400$ mm
 Large type sensor : $\phi 200$ to $\phi 1000$ mm

Measurement range:
 0 to ± 0.3 : \pm Maximum Velocity (depending on the pipe diameter)
 Refer to chart, table.1.
 Note) This function is to observe flow velocity profile, and it may be different from actual flow rate.

DETECTOR FOR FLOW VELOCITY PROFILE MEASUREMENT (TYPE: FSDP)

Mounting method:
 Mounting on outside of existing pipe

Ambient temperature: -20 to +80°C

Ambient humidity: 100% RH or less

Type of enclosure:
 IP67 (with waterproof BNC connector provided.)

Material:
 Sensor housing: PBT
 Guide frame: Aluminum alloy
 Mounting belt: Plastic cloth belt/stainless belt

Measurement principle

<Pulse Doppler method>

- Ultrasonic pulses are transmitted through the fluid flow. Entrained bubbles and microscopic particles within the fluid create frequency phase shifts (Doppler effect.) The resulting doppler shifts are integrated across the inside pipe diameter cross section. The resulting profile curve is a real-time dynamic display of the flow profile within the pipe.

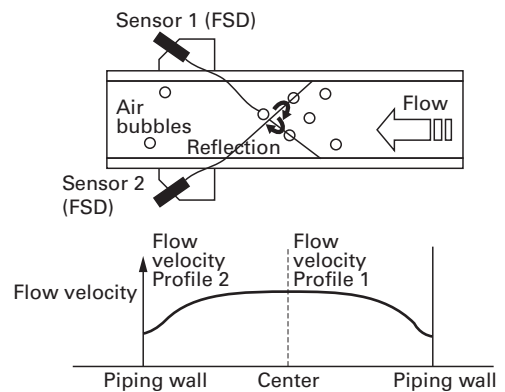

The above shows an example when using two sensors. One detector displays the flow velocity profile for a radius.

Block diagram

(1) Using one sensor

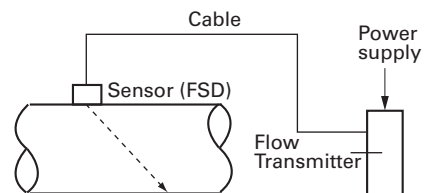

(2) Using two sensors

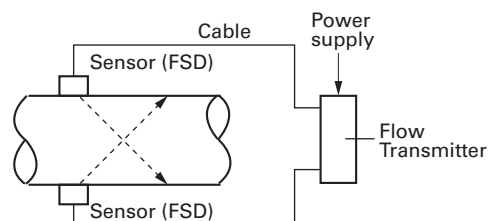

Table.1

Maximum measurement range of Pulsed Doppler method.

When nominal thickness of a stainless pipe of pipe material is Sch20s and the fluid is water, the maximum measurement range varies depending on the outer diameter of pipe, nominal thickness, material, or fluid type.

<Maximum measurable flow velocity>				<Maximum measurable flow rate>		
Diameter	Unit: m/s			Unit: m ³ /h		
	FSDP2	FSDP1	FSDP0	FSDP2	FSDP1	FSDP0
40A	6.56			33.6		
50A	6.52			52.7		
65A	5.31			72.1		
80A	4.65			86.5		
90A	4.12			102		
100A	3.69	7.25		118	231	
125A	3.08	6.08		147	289	
150A	2.63	5.20		179	354	
200A	2.04	4.05	7.77	239	474	908
250A		3.30	6.38		604	1168
300A		2.78	5.41		735	1428
350A		2.51	4.90		820	1598
400A		2.20	4.31		951	1858
450A			3.80			2118
500A			3.48			2358
550A			3.17			2618
600A			2.91			2879
650A			2.71			3096
700A			2.52			3357
750A			2.35			3618
800A			2.21			3879
850A			2.08			4140
900A			1.97			4400
1000A			1.77			4902

PC Loader software

Equipped as standard

- PC/AT compatible machines. (Operation on custom built PCs or shop-brand PCs cannot be guaranteed.)
- Major functions: Performs parameter (site setting) display /change of the main unit and collects measured date.
Instantaneous velocity, instantaneous flow rate, total value, error information, received waveform, analog input, logger data, etc. may be downloaded in a personal computer.
- O/S: Windows2000/XP/Vista*
- Memory requirement: 128MB or more
- Disk unit: Windows2000/XP/Vista-compatible CD-ROM drive
- Hard disk drive capacity: Free space of 64MB or more

* Windows Vista: Use it in basic mode.
It is not available for Windows Aero.

CODE SYMBOL

<Flow transmitter>

1 2 3 4 5 6 7 8 9 10 11											Description	
F	S	C						1	-	0		<Specification> Standard
	S											<Converter> Basic system Basic system + Printer
								0				<Flow velocity profile measurement> None Provided (detector to measure flow velocity profile is separately required.)
											A	<Power adapter> AC power + power cord (125V AC) for Japanese and North American use AC power + power cord (250V AC) for European and Korean use AC power + power cord (250V AC) for Chinese use
												Modification No.
												<SD memory card> None Provided (256MB)
												<Bound instruction manual/Language> None (Factory-set language: English) Provided/Japanese (Factory-set language: Japanese) Provided/English (Factory-set language: English) Provided/Chinese (Factory-set language: Chinese) (Note1) Instruction manual contained in CD is the standard attached article. (Note2) You can change the language by key operation.

<Detector> (for transit time)

1 2 3 4 5 6 7 8								Description		
F	S	D						<Kind> Small type (for $\phi 50$ to $\phi 400$ mm) *1) *2) Small diameter (for $\phi 13$ to $\phi 100$ mm) Middle type (for $\phi 200$ to $\phi 1200$ mm) Large type (for $\phi 200$ to $\phi 6000$ mm) High-temperature (for $\phi 50$ to $\phi 400$ mm) *1) *2)		
	1	2						<Terminal mold> None Provided (Middle/Large type only)		
							Y	<Structure> General use		
							1	Modification No.		

Note)

*1) Applicable diameter range:

V method: $\phi 50$ to $\phi 250$ (FSD32), $\phi 50$ to $\phi 300$ (FSD12)

Z method: $\phi 150$ to $\phi 400$ (FSD32, FSD12)

Use the optional guide rail, if a pipe that does not allow ultrasonic waves to pass through easily, such as when an old pipe, cast iron pipe or a pipe with mortar lining is used, or the flow or liquid high in turbidity is measured. Employ the Z method for mounting.

(for flow velocity profile measurement)

1 2 3 4 5 6 7 8								Description		
F	S	D			0	Y	1	<Kind> Small type ($\phi 40$ to $\phi 200$ mm) Middle type ($\phi 100$ to $\phi 400$ mm) Large type ($\phi 200$ to $\phi 1000$ mm)		
							P 2	<Terminal mold> None		
							P 1	<Structure> General use		
							P 0	Modification No.		

SCOPE OF DELIVERY

<Flow transmitter>

Name of unit	Scope of delivery
1 Basic system	1) Conversion unit 2) Power adapter 3) Power connector conversion cord 4) Power cord 5) Analog input/output cord (1.5m) 6) USB cable (1m) 7) Carrying case 8) Strap 9) Special type signal cable (5m \times 2) 10) BNC adapter 11) CD-ROM (Instruction manual and Loader software for PC)
2 Option	1) Printer unit + rolled paper (1 roll) 2) SD memory card (256MB) 3) Bound instruction manual (including a detector)

<Detector>

Name of unit	Scope of delivery
1 Detector for propagation time difference (FSD)	1) Sensor unit 2) Signal cable (5m) (included with FSD41, 51) 3) Mounting belt/wire 4) Silicone grease (100g)
2 Detector for flow velocity profile (FSDP)	1) Detector unit 2) Mounting belt/wire 3) Silicone grease (100g)

Note 1) Silicon grease is for filling a gap between a detector and a pipe joint area. It is provided with a detector. Since silicon grease does not become hardened, if you use it in the long term, periodic maintenance is required. (Under the condition of room temperature, semiannual cleaning and refill is recommended.)

Note 2) When you order a detector alone, an instruction manual is not provided. Please request, if necessary.

OPTIONAL ITEMS

	Name	Specifications	Arrange-ment No.
1	Battery	Special type Li-ion battery (7.4V, 2500mAh) \times 2	ZZP*TK7N6384P1
2	Power adapter	Special type power adapter 90 to 264V AC, 50/60Hz · AC power adapter · Power connector conversion code	ZZP*TK7N6383P1 ZZP*TK4J2637C1
3	Power code	Japan, North America: 125V AC 2m Europe, Korea: 250V AC 2m China: 250V AC 2m	ZZP*TK7N6621P1 ZZP*TK7N6608P1 ZZP*TK7N6609P1
4	Printer unit	To be mounted on top of converter Thermal serial dot system (8 \times 384 dot)	ZZP*TK4J2634C1
5	Printer roll paper	Maker: SEIKO I SUPPLY Co. Ltd. Type: TP-211C-1 Specifications: Thermal roll paper Width: 58mm \times ϕ 48mm, No core	ZZP*TK7N6381P1
6	Silicone grease	Maker: Shin-Etsu Chemical Co., Ltd. Type: · For standard use G40M, 100g · For high temperature KS62M, 100g	ZZP*45231N5 ZZP*TK7G7983C1
7	Signal cable	Special type signal cable, 5m \times 2 · Connector on both sides · FSD41 (Connector on one side) · FSD51 (Connector on one side) · BNC adapter (\times 2)	ZZP*TK7N7795C1 ZZP*TK7N7795C2 ZZP*TK7N7795C3 ZZP*TK7N6323P11
8	Extension signal cable	Special type coaxial cable with BNC connector · 10m \times 2 · 50m \times 2	ZZP*TK468664C3 ZZP*TK468664C4
9	Analog input/output cable	6-core cable, 1.5m, with connector	ZZP*TK4J2639C1
10	Mounting belt /wire	· Small type/small diameter sensor: Plastic cloth belt · Large type sensor: Stainless wire Nominal diameter f200 to f500mm f200 to f1000mm f200 to f2000mm f200 to f3000mm f200 to f6000mm · High-temperature sensor: Stainless steel belt	ZZP*TK7G7979C1 ZZP*TK7G7980C1 ZZP*TK7G7980C2 ZZP*TK7G7980C3 ZZP*TK7G7980C4 ZZP*TK7G7980C5 ZZP*TK7G7981C1
11	Guide rail for high-temperature sensor (In mounting by the Z method)	· Mounting bracket material: Aluminum alloy+SUS304	ZZP*TK4C6164C1
12	Guide rail for small type detector (In mounting by the Z method)	· Mounting bracket material: Aluminum alloy+plastic	ZZP*TK4J5917C1
13	SD memory card	Maker: Apacer Technology, Inc. Type: AP-ESD256TPSR Capacity: 256MB	ZZP*TK7N6386P1
14	USB cable	Maker: Sunwa Supply Inc. Type: KU-AMB510 Specifications: Mini USB cable (1.0m)	ZZP*TK7N6622P1

Diagram

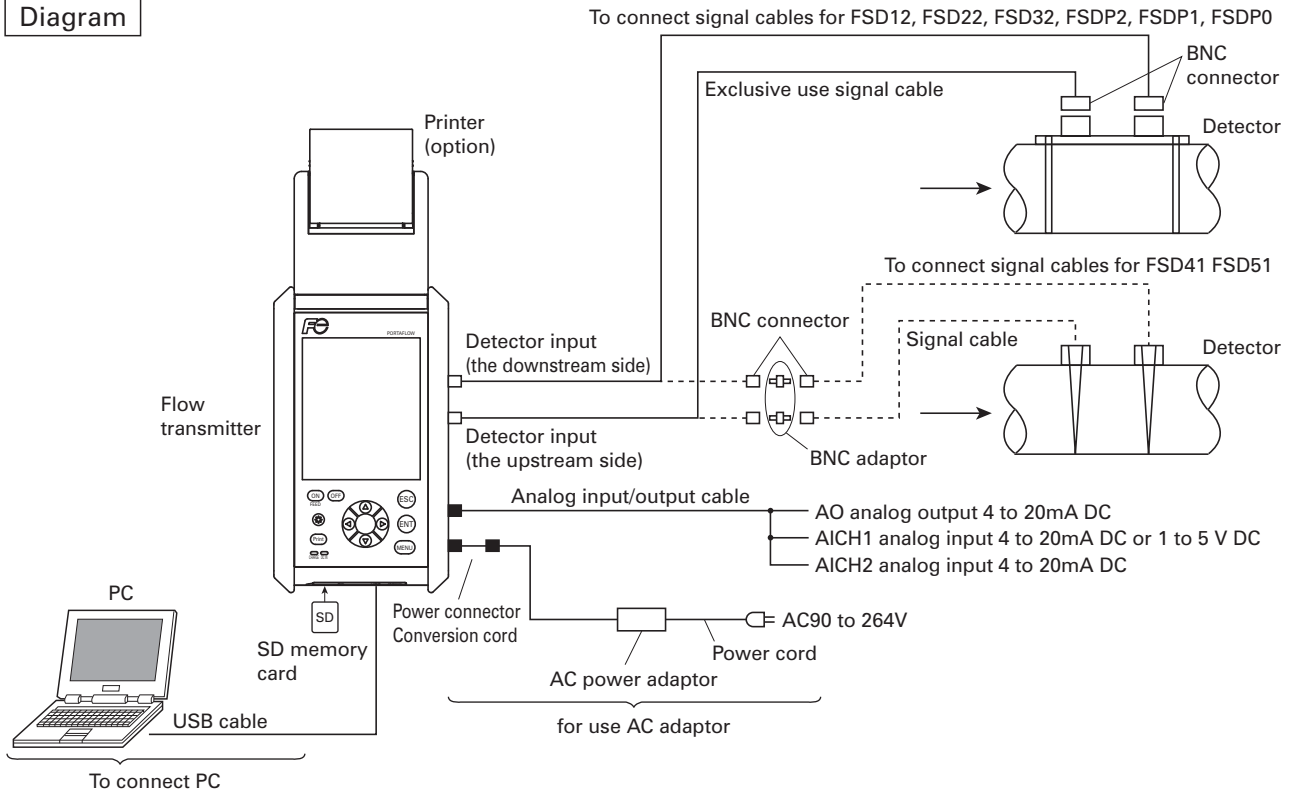

Conditions on straight pipe

(D: Nominal diameter of pipe)

Type	Length of upstream straight pipe	Length of downstream straight pipe
90° bend		
Tee		
Diffuser		
Contraction pipe		
Valve		
Pump		

Note) Source: Japan Electric Measuring Instruments Manufacturers' Association (JEMIS-032)

OUTLINE DIAGRAM (Unit:mm)

Flow transmitter

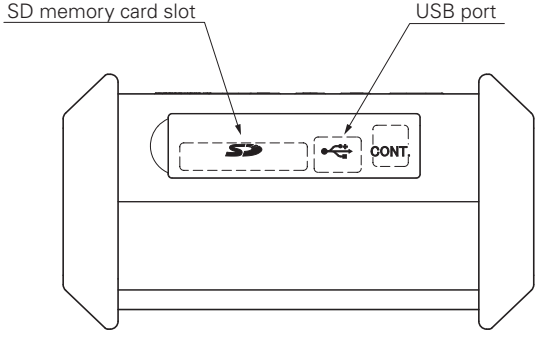
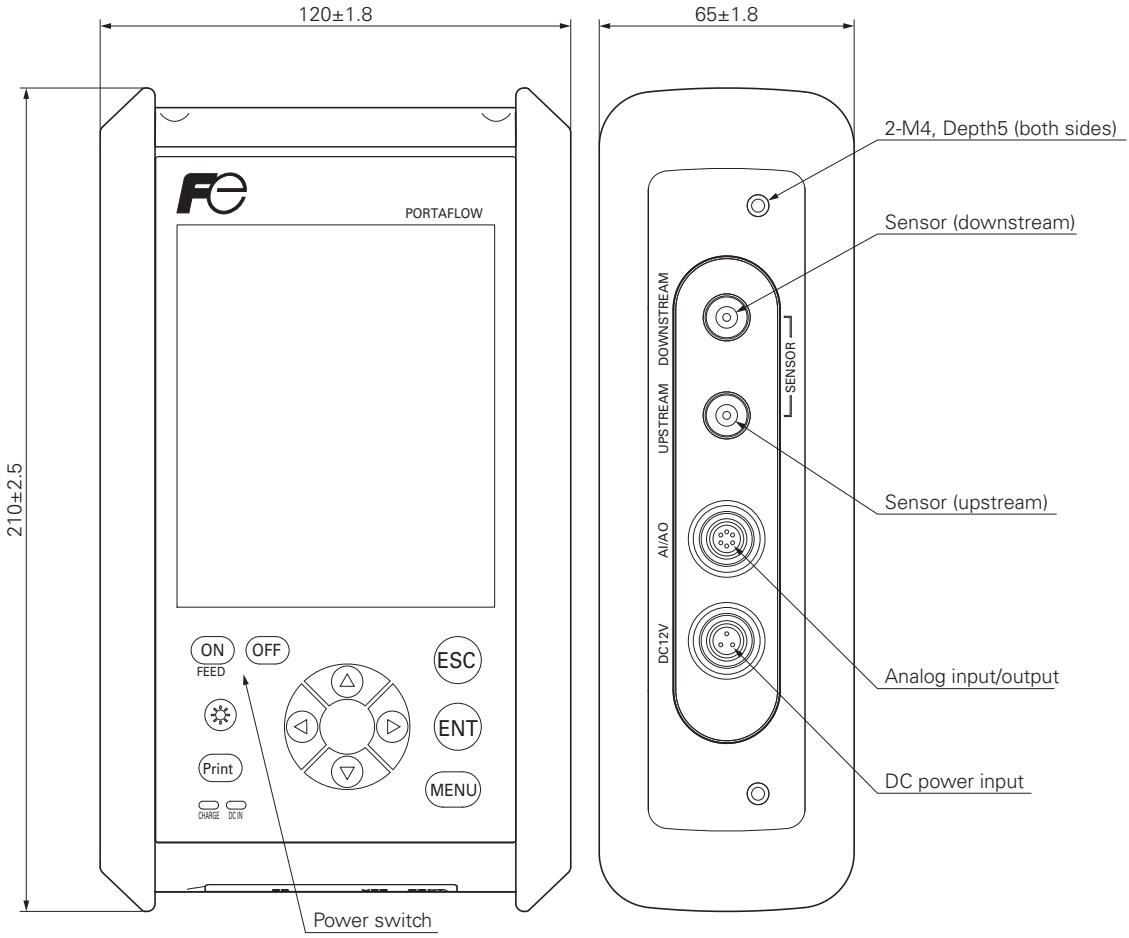

Weight : Approx. 1.0kg

OUTLINE DIAGRAM (Unit:mm)

Flow transmitter (with printer)

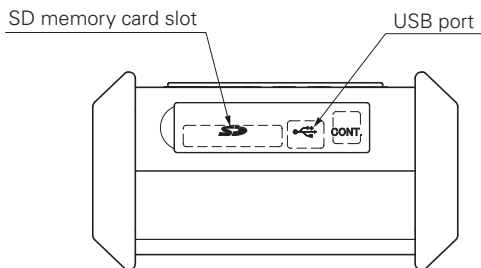
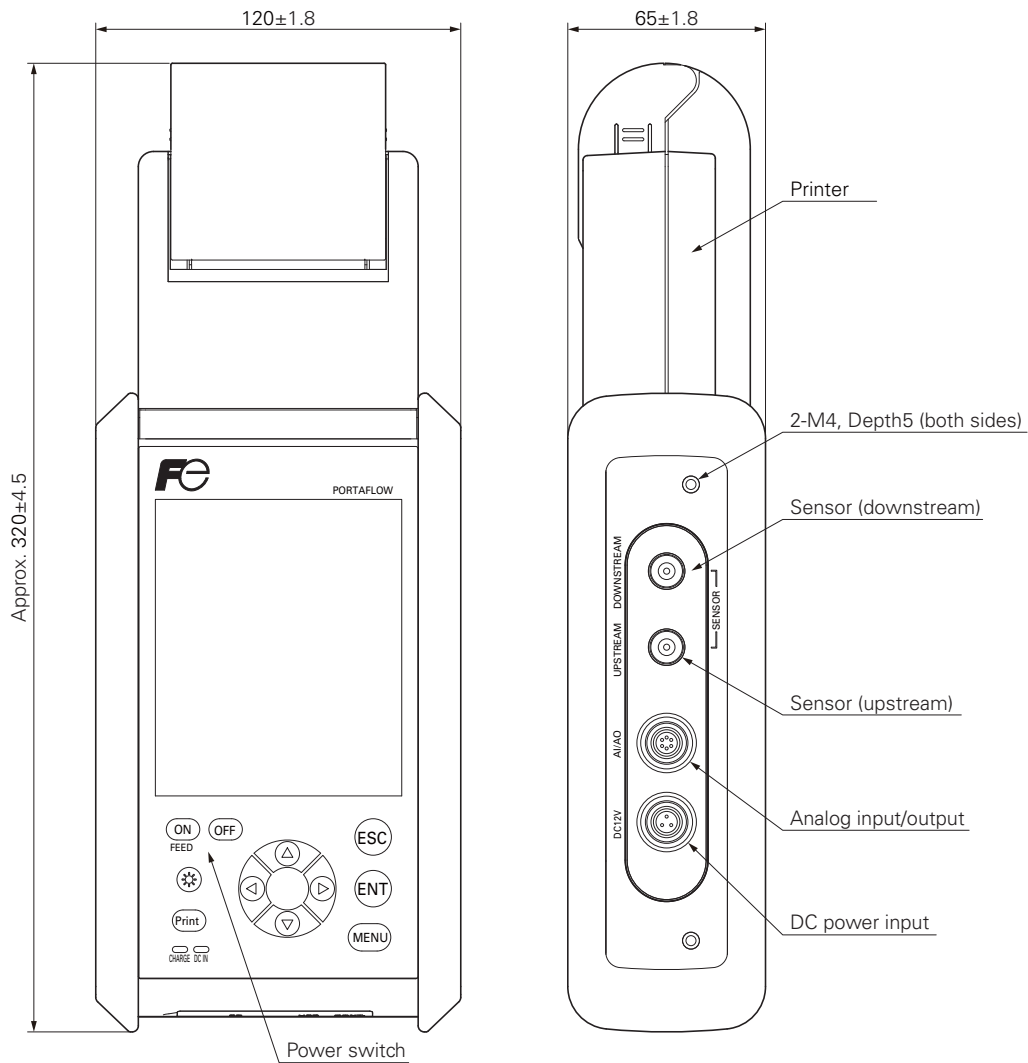

Weight : Approx. 1.2kg

OUTLINE DIAGRAM (Unit:mm)

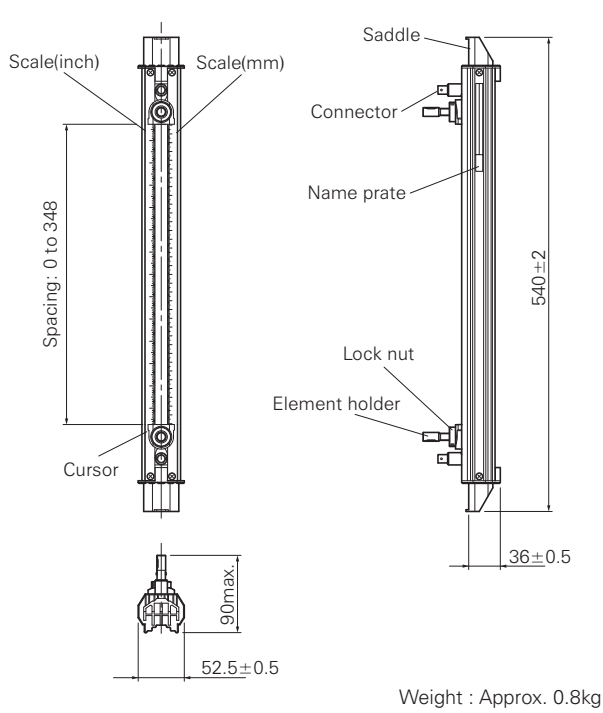

Detector FSD12 (Small type)

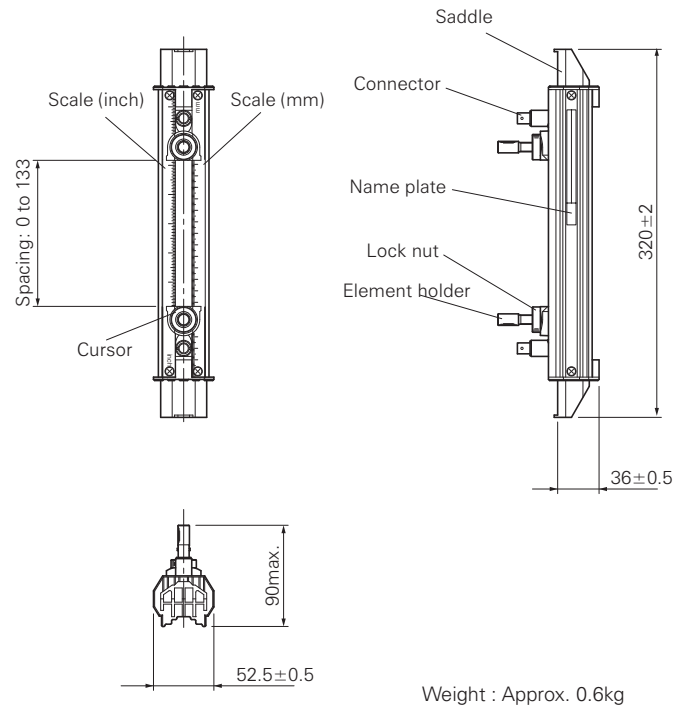

Detector FSD22 (Small diameter)

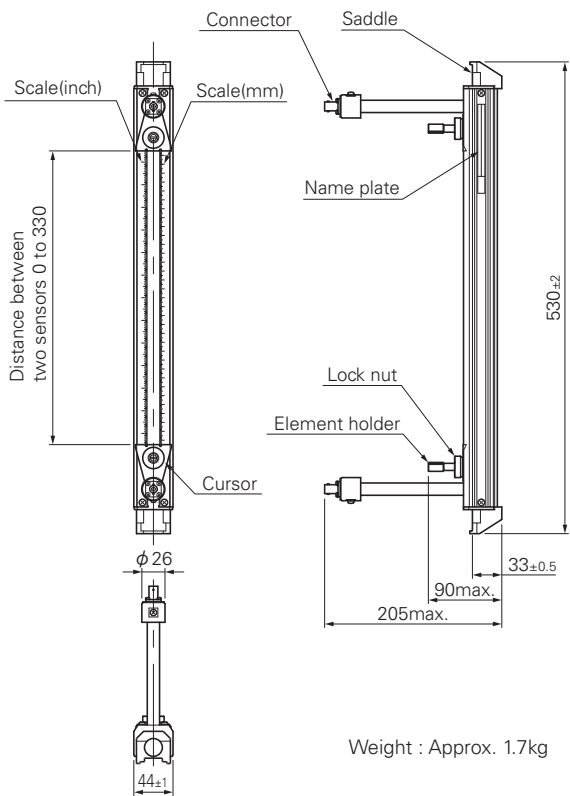

Detector FSD32 (High-temperature)

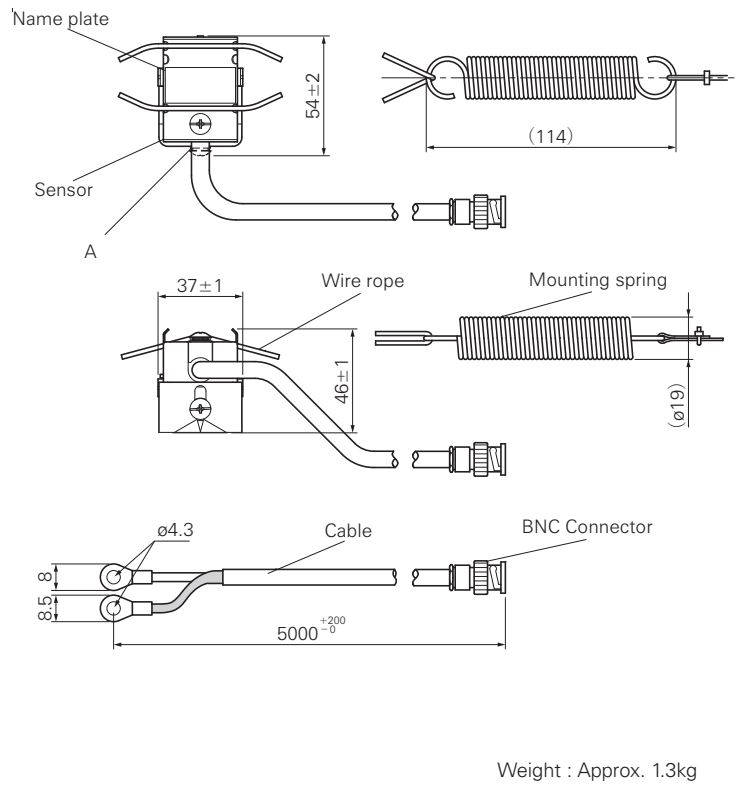

Detector FSD41 (Middle type)

OUTLINE DIAGRAM (Unit:mm)

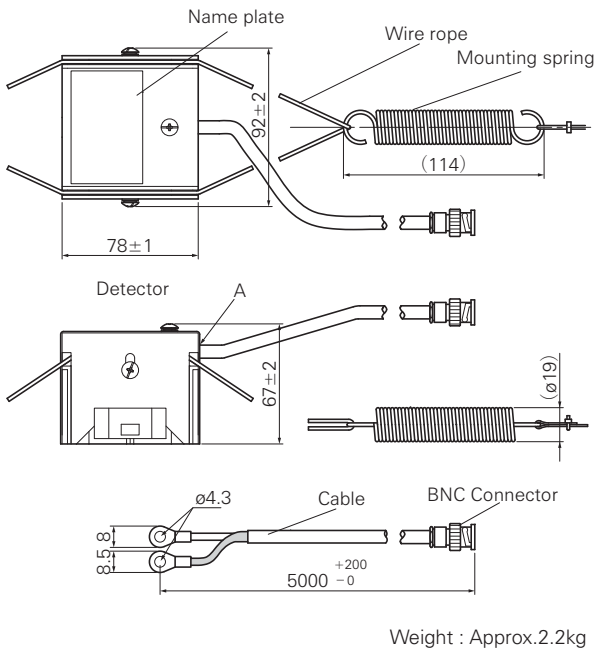

Detector FSD51 (Large type)

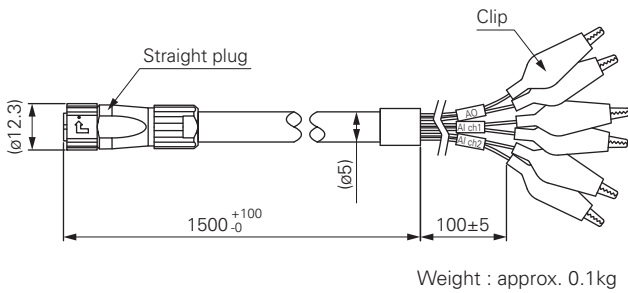

Code color	Clip color	Mark
Black (BK)	Red (R) (+)	AO
White (W)	Black (BK) (-)	
Red (R)	Red (R) (+)	AI ch1
Green (G)	Black (BK) (-)	
Yellow (Y)	Red (R) (+)	AI ch2
Brown (BN)	Black (BK) (-)	

Analog input/output cable

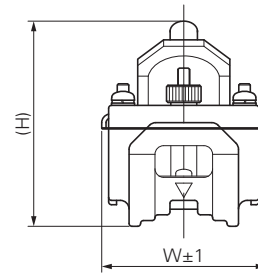
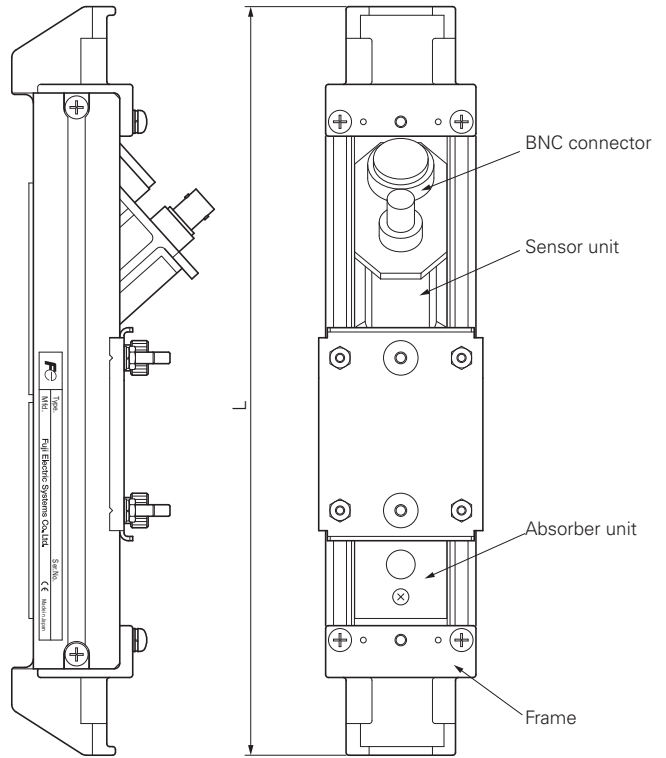

Type	Diameter (mm)	L	H	W	Weight Approx. (kg)
FSDP2	φ40 to φ200	260±1.2	70	57	0.8
FSDP1	φ100 to φ400	260±1.2	72	57	0.9
FSDP0	φ200 to φ1000	350±2.0	90	85	2.0

Detector FSDP (Detector for flow velocity profile measurement)

⚠ Caution on Safety

*Before using this product, be sure to read its instruction manual in advance.

Fuji Electric

Your distributor:

Coulton Instrumentation Ltd

17 Somerford Business Park, Christchurch, BH23 3RU, UK

Tel: +44 1202 480 303

E-mail: sales@coulton.com

Web: www.coulton.com