



# KA10 "ANSI 150/300"

ANSI Std Control Valves / Valvole di Regolazione ANSI

ssKA10- 05/2014

## DESCRIZIONE

**KA10** è una valvola due vie a singolo seggio con flusso avviato, disegnata per offrire una gamma completa di valvole di controllo di fluidi come vapore, acqua, olio, e per fluidi industriali in generale.

L'elevato valore di rangeability, la progettazione modulare e la flessibilità di questa serie, permettono di soddisfare le molteplici necessità di controllo dei processi industriali dai più semplici ai più gravosi.

Innumerevoli configurazioni sono disponibili, come: passaggi ridotti, trim antirumore ed anticavitazione, per soddisfare tutte le esigenze di controllo e di regolazione.

## DESCRIPTION

Manufactured under ISO 9001 quality assurance system, the OMC **KA10** series is a top entry globe valve style body construction with a wide range of different single stage trims available. **KA10** series combine the advanced modular design and the wide range of actuators to satisfy the needs of the industrial demand.

**KA10** valves are designed to control a broad variety of fluids, like steam, water, most of the medium and gases. One of the main features of this serie is the top guided construction that assure a stable plug travel over entire stroke of the valve minimizing vibration and wear.

## 1/2" ÷ 8" ANSI 150/300



**CALCOLATE SECONDO LA NORMA ASME B16.34  
EXTRA SPESSORE +40%**

**ACCORDING TO ASME B16.34 STANDARD  
+40% EXTRA THICKNESS**



Directive 97/23/EC  
Direttiva 97/23/CE

**PED**



Disponibile - Available  
94/9/EC (ATEX): II 2 G D c IIC X

**ATEX**

## CARATTERISTICHE COSTRUTTIVE

Da 1/2" a 8" ANSI 150/300
Otturatore guidato "Top Guide" standard per garantire maggior stabilità
Morsetto CEI EN 60534-6-1 std (ex.IEC534)
Packing a doppia tenuta
Classe di tenuta disponibili : IV (Std), V, VI

## DESIGN FEATURES

From 1/2" to 8" ANSI 150/300
Top Guided std construction to ensure plug stability
CEI EN 60534-6-1 clamp Std (ex.IEC534)
Double V-Ring packing spring loaded
Shutoff capabilities : Class IV (Std), V, VI



Our products are manufactured under ISO-9001 Quality Assurance System, approved by CSQ. Certified under nr.9190.OMC2 - **FIRST ISSUE 1994/08/04**

## OPZIONI :

Passaggi ridotti su misura
Interni stellati per pressione differenziale elevata
Otturatori bilanciati per alte pressioni
Gabbie antirumore e anticavitazione
Otturatori a microflusso per basse portate
Packing con soffiello di tenuta per emissioni "ZERO" (ZEB20)
Bonnet allungato per basse temperature
Bonnet alettato per alte temperature
Gamma completa di accessori ( posizionatori, ritrasmissione, lock -up, contatti di allarme, etc...)
Costruzione conforme <b>NACE0175/2003</b> o <b>ISO15156</b> (su richiesta)
Terminali a saldare

## OPTIONS :

Reduced area trim to provide wide capabilities for all sizes
Hardened trims to handle high pressure drop applications.
Balanced trims to handle high pressure drop & shutoff
Low noise & anticavitation design cage
Reduced capacity & low flow trim in all sizes
Bellows seal to meet zero emissions (ZEB20)
Extended bonnet for low temperature
Finned bonnet for high temperature
Available accessories : positioners, position transmitter, limit switches, lock-up etc..
<b>NACE 0175/2003</b> or <b>ISO15156</b> Construction on request
Butt Welding ends / Socket Welding ends

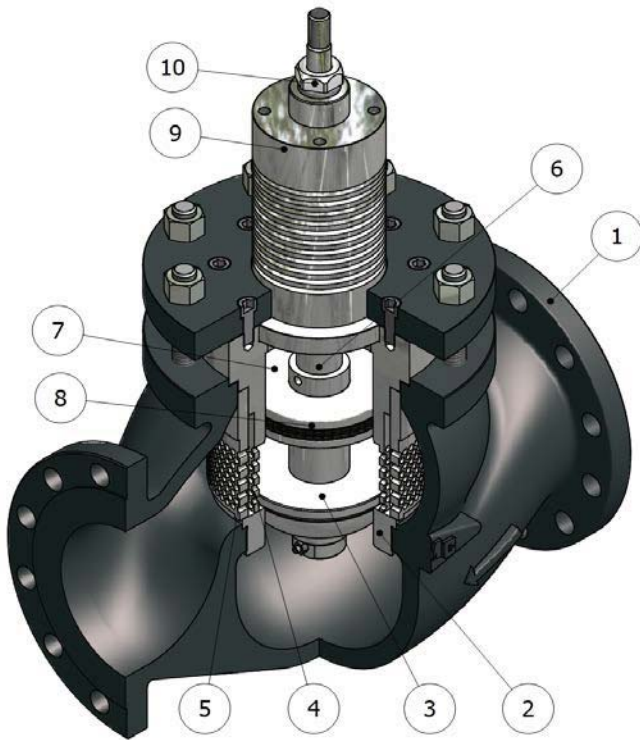

**LEGENDA**

1- Corpo valvola
2- Sede
3- Otturatore
4- Prima gabbia antirumore
5- Seconda gabbia antirumore
6- Stelo Top-Guide
7- Camera di bilanciatura
8- Pistone di bilanciatura
9- Bonnet
10- Premistoppa

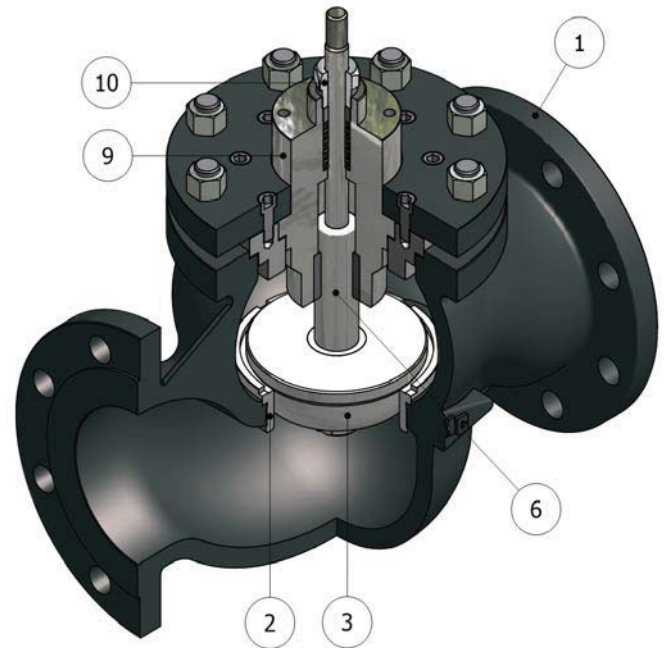

**LEGEND**

1- Body Valve
2- Seat Ring
3- Plug
4- 1st low dB / anticavitation cage
5- 2nd low dB / anticavitation cage
6- Top-guide steam
7- Balancing sleeve
8- Balancing piston
9 - Valve Bonnet
10- Stuffing box

## DATI TECNICI CORPO VALVOLA

TIPO	Top Entry, globo a singola sede
DIAMETRI NOMINALI	da 1/2" a 8"
RATING DEL CORPO	Classe ANSI 150, 300
COSTRUZIONE	ANSI B16.34
FLANGE	ANSI B16.5 Cl. 150,300 RF
SCARTAMENTO	ANSI / ISA 75.08.01

## VALVE BODY CHARACTERISTICS

Style	Top Entry, single seated, globe valve
SIZES	from 1/2" to 8"
PRESSURE RATING	ANSI Class 150, 300
DESIGN STD	ANSI B16.34
FLANGES CONNECTIONS	ANSI B16.5 Cl. 150,300 RF
BODY FACE TO FACE DIMENSIONS	In accordance with ANSI / ISA 75.08.01

## MATERIALI GRUPPO CORPO STD

Corpo Valvola (ANSI150 / 300): Acciaio al Carbonio A216 WCC	Bonnet: ASTM A105
	Interni: ASTM A213 Tipo 304 (Tipo 316 su richiesta)
Corpo Valvola (ANSI150 / 300): Acciaio INOX A351 CF8M	Bonnet : ASTM A213 Tipo 304 (Tipo 316 su richiesta)
	Interni: ASTM A213 Tipo 304 (Tipo 316 su richiesta)

## STD BODY & TRIM MATERIALS COMBINATION

Valve Body (ANSI150 / 300): Carbon steel A216 WCC	Bonnet: ASTM A105
	Trim: ASTM A213 Type 304 (Type 316 on request)
Valve Body (ANSI150 / 300): Stainless steel A351 CF8M	Bonnet: ASTM A213 Type 304 (Type 316 on request)
	Trim: ASTM A213 Type 304 (Type 316 on request)

## RIVESTIMENTI PROTETTIVI STANDARD

Corpo Valvola	per temperature $\geq -10 / \leq 150^{\circ}\text{C}$	- Fondo bicomponente acrilico anticorrosivo ad alta resistenza - Finitura con smalto acrilico alifatico bicomponente RAL 7021 opaco
	per temperature $>150 / \leq 250^{\circ}\text{C}$	- Fondo epos siliconico - Finitura smalto acril siliconico RAL 9005
	per temperature $>250 / \leq 350^{\circ}\text{C}$	- Fondo epos siliconico termoresistente $400^{\circ}\text{C}$ RAL 9005+ opaco
Bonnet	per temperature $\geq -10 / \leq 350^{\circ}\text{C}$	- Zincatura elettrolitica Fe/Zn 8 c1A UNI ISO 4520

## STANDARD PROTECTIVE COATING

Valve Body	for temperature $\geq -10 / \leq 150^{\circ}\text{C}$	- Bicomponent anticorrosive acrylic primer at high resistance - Finish with bicomponent aliphatic acrylic enamel RAL 7021 opaque
	for temperature $>150 / \leq 250^{\circ}\text{C}$	- Epos/siliconic primer - Finish with epoxy/siliconic enamel RAL 9005
	for temperature $>250 / \leq 350^{\circ}\text{C}$	- Heat resistant epoxy/siliconic primer T. max. $400^{\circ}\text{C}$ RAL 9005+ opaque
Bonnet	per temperature $\geq -10 / \leq 350^{\circ}\text{C}$	- Electrolytic zinc coatings Fe/Zn 8 c1A UNI ISO 4520

## RIVESTIMENTI PROTETTIVI SU RICHIESTA

Corpo valvola e bonnet	- verniciatura per ambienti salini - verniciatura su specifica cliente
------------------------	---

## PROTECTIVE COATING ON REQUEST

Valve Body & Bonnet	- Painting for see environment - Customer specification
---------------------	--

## EQUIVALENZA MATERIALI CORPO

	European Std	ASTM Std	Limiti di Temperatura Temperature Application Limits
Acciaio al Carbonio Carbon Steel	1.0619 GP240GH	A216 WCC	-29+538°C
Acciaio Inox Stainless Steel	1.4408 X5CrNiMo	A351 CF8M	-196+816°C

## BODY MATERIALS CROSS REFERENCE

	European Std	ASTM Std	Limiti di Temperatura Temperature Application Limits
Acciaio al Carbonio Carbon Steel	1.0619 GP240GH	A216 WCC	-29+538°C
Acciaio Inox Stainless Steel	1.4408 X5CrNiMo	A351 CF8M	-196+816°C

**Relazione Pressione / Temperatura  
in accordo alla norma ASME B16.34**

**Relation between Pressure/Temperature  
according to ASME B16.34**

		MATERIAL A216 WCB - ASTM A105 - ASTM A350 LF2 - GROUP 1.1 ASME B16.34													
Carbon Steel	Temp. (°C)	-29°+38	50	100	150	200	250	300	350	400	425	450	475	500	538
	ANSI 150 (bar)	19,6	19,2	17,7	15,8	13,8	12,1	10,2	8,4	6,5	5,5	4,6	3,7	2,8	1,4
	ANSI 300 (bar)	51,1	50,1	46,6	45,1	43,8	41,9	39,8	37,6	34,7	28,8	23,0	17,4	11,8	5,9
		MATERIAL - A216 WCC - ASTM A350 LF3 GROUP 1.2 ASME B16.34													
Carbon Steel	ANSI 150 (bar)	19,8	19,5	17,7	15,8	13,8	12,1	10,2	8,4	6,5	5,5	4,6	3,7	2,8	1,4
	ANSI 300 (bar)	51,7	51,7	51,5	50,2	48,6	46,3	42,9	40,0	34,7	28,8	23,0	17,1	11,6	5,9
			MATERIAL ASTM A351 CF8 - ASTM A479 304 - ASTM A 240 304 - GROUP 2.1 ASME B16.34												
Stainless Steel	Temp. (°C)	-196°+38	50	100	150	200	250	300	350	400	425	450	475	500	538
	ANSI 150 (bar)	19	18,3	15,7	14,2	13,2	12,1	10,2	8,4	6,5	5,5	4,6	3,7	2,8	1,4
	ANSI 300 (bar)	49,6	47,8	40,9	37,0	34,5	32,5	30,9	29,6	28,4	28,0	27,4	26,9	26,5	24,4
		MATERIAL ASTM A351 CF8M - EN10213-4 1.4408 - ASTM A479 316 - ASTM A 240 316 - GROUP 2.2 ASME B16.34													
Stainless Steel	ANSI 150 (bar)	19,8	19,5	18,1	16,5	15,3	14,3	13,5	13,0	12,6	12,5	12,3	12,3	12,1	11
	ANSI 300 (bar)	51,7	50,8	47,1	43,0	39,8	37,3	35,3	33,8	32,9	32,5	32,2	32,0	31,7	29,0

**COMBINAZIONE CORPO & TRIM con MATERIALI SPECIALI**

**COMBINATION BODY & TRIM for SPECIAL MATERIALS**

Corpo Valvola (ANSI150 / 300): Acc.al Carbonio per basse temp. .A352LCB/LCC Appl. limits (-46 + 343 °C)	Bonnet: ASTM 352 LF2	Valve Body (ANSI150 / 300): Carbon steel A352LCB/LCC Appl. limits (-46 + 343 °C)	Bonnet: ASTM 352 LF2
	Interni: ASTM A213 Tipo 304 (Tipo 316 su richiesta)		Trim: ASTM A213 Type 304 (Type 316 on request)
Corpo Valvola (ANSI150 / 300): Acciaio INOX A351 CF8	Bonnet : ASTM A213 Tipo 304 (Tipo 316 su richiesta)	Valve Body (ANSI150 / 300): Stainless steel A351 CF8	Bonnet: ASTM A213 Type 304 (Type 316 on request)
	Interni: ASTM A213 Tipo 304 (Tipo 316 su richiesta)		Trim: ASTM A213 Type 304 (Type 316 on request)
Corpo Valvola (ANSI150 / 300): DUPLEX ASTM A-890 4A (SAF 2205)	Bonnet: ASTM A-276 S31803	Valve Body (ANSI150 / 300): DUPLEX ASTM A-890 4A (SAF 2205)	Bonnet: ASTM A-276 S31803
	Interni: ASTM A-276 S31803		Interni: ASTM A-276 S31803
Corpo Valvola (ANSI150 / 300): MONEL ASTM A-494 M-35-1	Bonnet : ASTM B-164-98	Valve Body (ANSI150 / 300): MONEL ASTM A-494 M-35-1	Bonnet: ASTM B-164-98
	Interni: ASTM B-164-98		Trim: ASTM B-164-98

**BONNET**

**BONNET**

STANDARD	Standard per temp. 23+392°F (-5 ±200°C)	STANDARD TYPE	Standard for 23+392°F (-5 ±200°C)
A RICHIESTA	Alettato per temp. >392°F (>200°C)	ON REQUEST	Finned for temp. >392°F (>200°C)
	Allungato per temp. <23°F (<-5°C)		Extended fof temp. <23°F (<-5°C)



**Prolungato / Extended**



















**Standard**



**Alettato / Finned**

## TENUTA STELO

## PACKING

<b>HT200</b> per temp. $\leq 392^{\circ}\text{F}$ Standard da 1/2" a 4"	
<b>GR20 - GRAFITE PURA</b> $\leq 752^{\circ}\text{F}$ Standard da 6" a 8"	
<b>HTS300</b> per temp. $\leq 752^{\circ}\text{F}$ A richiesta da 1/2" a 4"	
<b>GreenPack 1</b> per temp. $\leq 842^{\circ}\text{F}$ Basse emissioni / Autoestinguente A richiesta da 1/2" a 4"	<b>Ta-Luft</b>  
<b>GreenPack 2</b> per temp. $\leq 842^{\circ}\text{F}$ Basse emissioni / Autoestinguente A richiesta da 6" a 8"	<b>Ta-Luft</b> 
<b>ZEB20 - Soffietto</b> per fluidi pericolosi - Zero Emissioni A richiesta da 1/2" a 8"	 
<b>HT200</b> for temp. $\leq 392^{\circ}\text{F}$ Standard from 1/2" to 4"	
<b>GR20 - PURE GRAPHITE</b> $\leq 752^{\circ}\text{F}$ Standard from 6" to 8"	
<b>HTS300</b> for temp. $\leq 752^{\circ}\text{F}$ On Request from 1/2" to 4"	
<b>GreenPack 1</b> for temp. $\leq 842^{\circ}\text{F}$ Low Emissions / Firesafe On Request from 1/2" to 4"	<b>Ta-Luft</b>  
<b>GreenPack 2</b> for temp. $\leq 842^{\circ}\text{F}$ Low Emissions / Firesafe On Request from 6" to 8"	<b>Ta-Luft</b> 
<b>ZEB20 - Bellows</b> sealed for dangerous fluids - Zero Emissions On Request from from 1/2" to 8"	 



**SENZA MANUTENZIONE  
MAINTENANCE FREE**



**BASSE EMISSIONI  
LOW EMISSIONS PACKING  
Ta-Luft**



**ZERO EMISSIONI  
ZERO EMISSIONS PACKING**

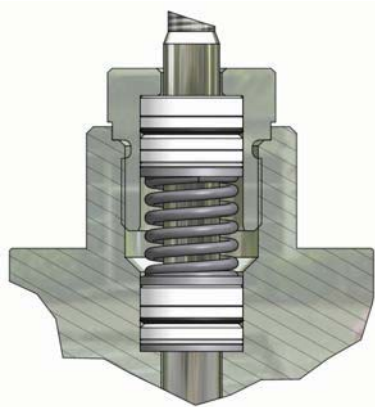

**HT200**

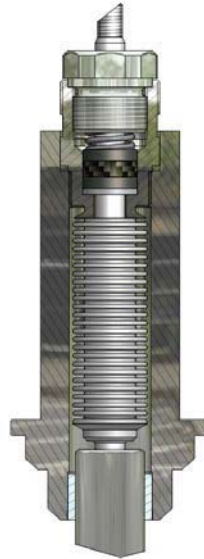

**ZEB20**

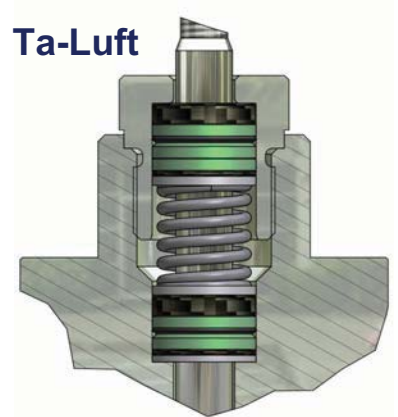

**GreenPack 1**

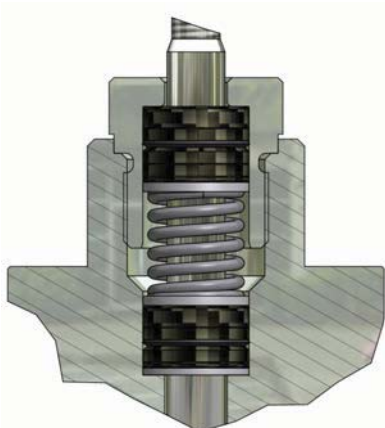

**HTS300**

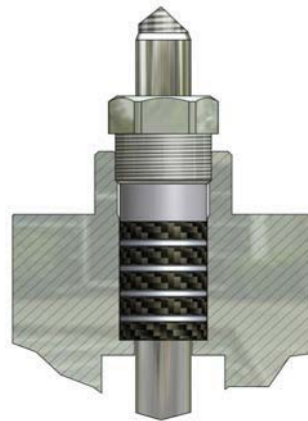

**GR20**

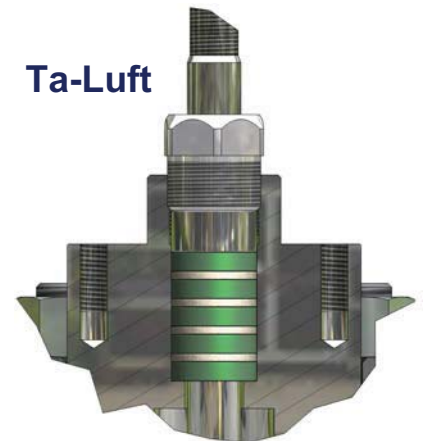

**GreenPack 2**

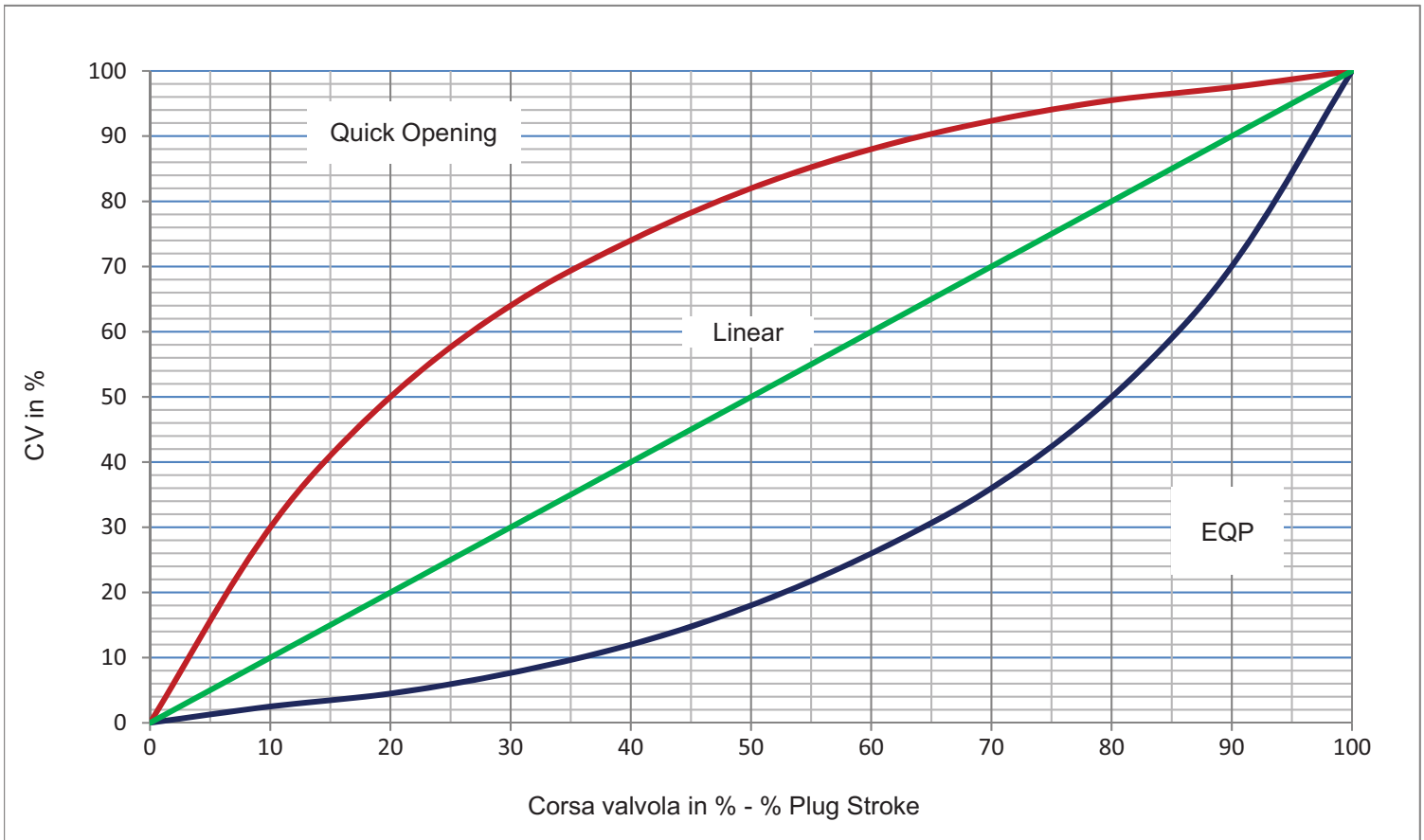

**Caratteristica otturatore ad apertura rapida**

Una valvola con otturatore ad apertura rapida permette una massima variazione di portata con una corsa minima dell'otturatore e una minima variazione di portata quando l'otturatore della valvola è prossimo alla corsa massima. Le valvole con otturatore ad apertura rapida sono utilizzate spesso per applicazioni ON/OFF quando è necessario avere la massima portata nel minor tempo possibile.

**Quick Opening Flow Characteristic**

A valve with quick opening flow characteristic provides a maximum change in flow rate at low travels and small changes when the valve plug is near maximum. Control valves with quick opening flow characteristics are often used for on/off applications where significant flow rate must be established quickly as the valve begins to open. Consequently they are often used in relief valve applications.

Quick opening valves can also be selected for many of the same applications for which linear flow characteristics are recommended.

**Caratteristica otturatore lineare**

Una valvola con otturatore lineare fornisce una portata direttamente proporzionale alla corsa dell'otturatore. Le valvole con questa caratteristica sono frequentemente specificate per applicazioni liquido-livello e controllo di portata.

**Linear characteristic**

A valve with linear characteristic provide a flow rate directly proportional to travel. Linear characteristics are commonly specified for liquid-level and flow-control applications.

**Caratteristica otturatore equipercentuale (EQP)**

Nella caratteristica equipercentuale, a pari incremento di corsa dell'otturatore si ottiene una variazione equipercentuale della portata. Una valvola con questa caratteristica fornisce una precisione di controllo partendo da una minima corsa dell'otturatore e aumenta rapidamente la portata di efflusso quando è vicina alla massima apertura. Valvole con otturatore a caratteristica EQP sono le più utilizzate per applicazioni di controllo di pressione, per applicazioni quando una larga percentuale di caduta di pressione è normalmente assorbita dal sistema stesso e solo una minima percentuale deve essere controllata, e dove si possono avere grandi variazioni di pressione.

**Equal Percentage Flow Characteristic (EQP)**

In equal percentage flow characteristic, equal increments of valve travel produce equal percentage changes in the existing flow. A valve with an inherent equal percentage flow characteristic provides precise throttling control through the lower portion of the travel range and rapidly increasing capacity as the valve plug nears the wide open position. Valves with equal percentage flow characteristics are used on pressure control applications, on applications where a large percentage of the pressure drop is normally absorbed by the system itself with only a relatively small percentage available at the control valve, and on applications where highly varying pressure drop conditions can be expected.

## TRIMS

TENUTA	Tenuta metallica - Classe IV°
PROFILO OTTURATORE	Equipercentuale (EQP)
	ON-OFF (PT)
	Lineare (PL)
PASSAGGIO	Integrale
A RICHIESTA	Passaggio ridotto
	Passaggio microflusso
	Stellatura sede/ott. calsse IV°
	Tenuta soffice PTFE $\leq 300^{\circ}\text{F}$ ( $150^{\circ}\text{C}$ ) - Classe VI°
	Tenuta soffice PTFE/GR $\leq 375^{\circ}\text{F}$ ( $190^{\circ}\text{C}$ ) - Classe VI°

## TRIMS

SEAL	Metal seat tightness - Class IV°
PLUG TYPES	Parabolic Equal Perc. (EQP)
	ON-OFF (PT)
	Linear (PL)
PORT	Full Port
ON REQUEST	Reduced port
	Microflow port
	Stellite faced seat/plug Class IV°
	PTFE soft seal $\leq 300^{\circ}\text{F}$ ( $150^{\circ}\text{C}$ ) - Class VI°
	PTFE/GR soft seal $\leq 375^{\circ}\text{F}$ ( $190^{\circ}\text{C}$ ) - Class VI°

### Corsa / Stroke

CV (flow rate coefficients)	0,05 ÷ 47	73 ÷ 160	270 ÷ 650
Inches (mm)	0.79 (20)	1.18 (30)	2"(50)

Microflusso / Spline trim  
CV da 0,05



Otturatore bilanciato con gabbia anticavitazione e/o riduzione rumore

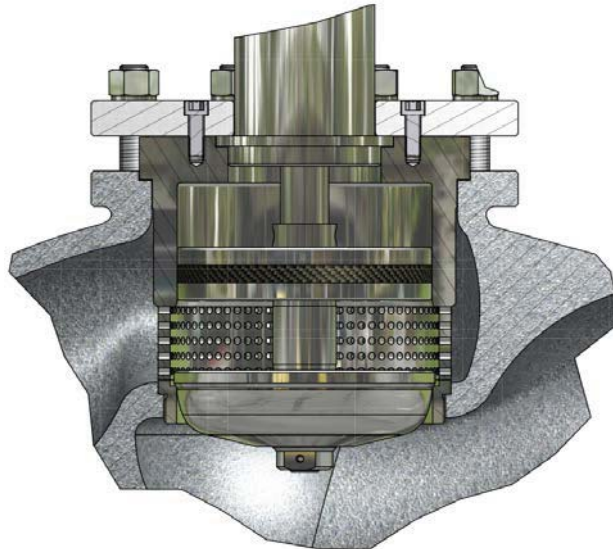

Balanced trim with cage noise reduction and/or anticavitation

Apertura rapida  
Quick-opening trim



EQP  
tenuta soffice  
soft tightness



EQP  
tenuta metallica  
metal tightness



Gabbia per riduzione rumore  
singolo stadio



Low dB Trim single stage

Gabbia riduzione rumore  
doppio stadio

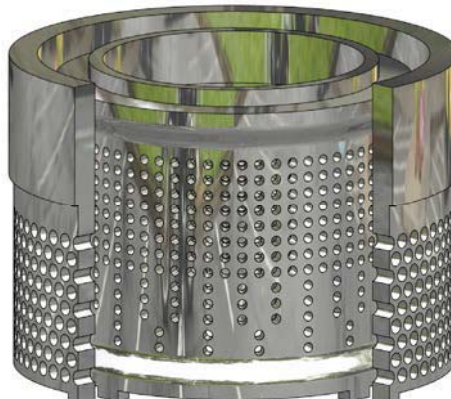

Low dB Trim double stage

Gabbia Anticavitazione



Anticavitation cage

## COEFFICIENTI DI PORTATA

(CV= portata in GPM con 1 psi di pressione differenziale)  
(Kv= portata in m³/h con 1 bar di pressione differenziale)

## FLOW RATE COEFFICIENTS

(CV= flowrate in USGPM with 1 psi of differential Pressure)  
(Kv= flowrate in m³/h with 1 bar of differential Pressure)

CV	Kv	DIAMETRO NOMINALE - SIZES																						
		1/2"	3/4"	1"	1,5"	2"	3"	4"	6"	8"														
0.05 ÷ 4	0.04 ÷ 3,5	■	■	■																				
4.5	3.8	std	■	■	■																			
6	5.1		std	■	■																			
11	9.4			std	■	■																		
18	15.4				■	■	■																	
27	22.2				std	■	■	■																
47	40.1					std	■	■																
73	63.4																				■			
105	89.7															std	■	■			■	■		
160	136.7																std	■	■		■	■		
270	230.8																				■	■		
370	316.2																				std	■		
650	555																						std	

non disponibile / not available

std

standard

■

su richiesta / on request

## ATTUATORE PNEUMATICO DI REGOLAZIONE

PRESSIONI DIFFERENZIALI MASSIME  
AMMISSIBILI IN BAR (Fluido Apre)

PER COSTRUZIONI CON OTTURATORI NON BILANCIATI

## CONTROL PNEUMATIC ACTUATOR

MAXIMUM ADMISSIBLE PRESSURE  
DROPS IN BAR (Fluid Open)

FOR UNBALANCED CONSTRUCTION

ATTUATORE E ACTUATOR	SEGNALE SIGNAL (psi)	CV 4.5		CV 6		CV 11		CV 18		CV 27		CV 47		CV 73		CV 105		CV 160		CV 270		CV 370		CV 650	
		cl. IV	cl. VI	cl. IV	cl. VI	cl. IV	cl. VI	cl. IV	cl. VI	cl. IV	cl. VI	cl. IV	cl. VI	cl. IV	cl. VI	cl. IV	cl. VI	cl. IV	cl. VI	cl. IV	cl. VI	cl. IV	cl. VI	cl. IV	cl. VI
AP23	3÷15	15	21	14	18	9	12	5	8	3	4	2	3	-	-	-	-	-	-	-	-	-	-	-	-
	6÷18	18	26	16	22	11	17	7	10	4	5	3	4	-	-	-	-	-	-	-	-	-	-	-	-
	6÷30	50	60	22	28	16	25	10	15	6	8	4	6	-	-	-	-	-	-	-	-	-	-	-	-
	15÷60	70	80	45	60	35	56	27	33	15	17	8	12	-	-	-	-	-	-	-	-	-	-	-	-
AP28	3÷15	31	35	27	30	17	26	8	15	6	9	4	6	-	-	-	-	-	-	-	-	-	-	-	-
	6÷18	40	45	38	40	21	30	13	19	10	12	5	8	-	-	-	-	-	-	-	-	-	-	-	-
	6÷30	55	60	50	55	26	47	23	26	12	16	7	12	-	-	-	-	-	-	-	-	-	-	-	-
	15÷60	99	99	80	90	48	75	40	56	25	38	17	23	-	-	-	-	-	-	-	-	-	-	-	-
AP34 / AP35	3÷15	60	65	60	65	50	55	20	23	12	18	10	16	4	4	2	3	1	1	-	-	-	-	-	-
	6÷18	80	85	80	85	60	65	30	35	15	18	12	15	6	7	4	5	2	3	-	-	-	-	-	-
	6÷30	99	99	99	99	80	85	40	45	20	25	14	16	7	8	5	6	2	3	-	-	-	-	-	-
	15÷60	-	-	-	-	-	-	62	65	36	45	25	29	11	13	8	11	6	6	-	-	-	-	-	-
AP43 / AP44	3÷15	-	-	-	-	-	-	-	-	35	40	24	26	7	8	6	6	4	4	-	-	-	-	-	-
	6÷18	-	-	-	-	-	-	-	-	40	45	26	28	9	10	8	8	5	5	-	-	-	-	-	-
	6÷30	-	-	-	-	-	-	-	-	40	45	26	28	12	12	10	10	6	6	-	-	-	-	-	-
	15÷60	-	-	-	-	-	-	-	-	65	85	40	70	28	37	22	27	15	17	-	-	-	-	-	-
AP45	15÷60	-	-	-	-	-	-	-	65	85	40	70	28	37	22	27	15	17	-	-	-	-	-	-	
AP46	15÷60	-	-	-	-	-	-	-	-	-	-	-	-	-	-	-	-	-	-	7	8	5	6	3	4
AP60	15÷60	-	-	-	-	-	-	-	-	-	-	-	-	-	-	44	54	30	34	14	16	10	12	6	8

cl.IV

Tenuta metallica - Classe IV° - ANSI FCI 70-2  
Metal seat tightness - Class IV° - ANSI FCI 70-2

cl.VI

Tenuta soffice - Classe VI° - ANSI FCI 70-2  
Soft seal- Class VI° - ANSI FCI 70-2

I valori espressi in tabella si riferiscono alla forza del servomotore, il rating del corpo ne limita l'applicazione.

The pressure drop values must be used within the body rating limit.



TIPO ATTUATORE	multimolla a membrana	
SEGNALI DI COMANDO	3÷15 psi 6÷18 psi 6÷30 psi	<b>15÷60 psi</b>
PRESSIONE MAX APPLICABILE	50 psi (3,5 bar)	<b>87 psi (6 bar)</b>
TEMPERATURA AMBIENTE	-20÷70°C	
MATERIALE CUSTODIA	Acciaio al Carbonio Fe410.1	
CASTELLO	Tipo Integrale in Acciaio al Carbonio ASTM A216 WCB	
MATERIALE MEMBRANA	NBR70 telata	
CONNESSIONI PNEUMATICHE	1/4"NPT-F	

TYPE	diaphragm type - multispring	
CONTROL SIGNAL	3÷15 psi 6÷18 psi 6÷30 psi	<b>15÷60 psi</b>
MAX AIR SUPPLY PRESSURE	50 psi (3,5 bar)	<b>87 psi (6 bar)</b>
AMBIENT TEMPERATURE	-20÷70°C	
ACTUATOR CASING MATERIAL	Carbon Steel Fe410.1	
YOKE MATERIAL	Integral Type in Carbon steel ASTM A216 WCB	
DIAPHRAGM MATERIAL	NBR70	
PNEUMATIC CONNECTIONS	1/4"NPT-F	

### RIVESTIMENTI PROTETTIVI

Standard	Verniciatura a polvere poliestere RAL 7032 (*)
----------	--

### PROTECTIVE COATING

Standard	Finish powder coat polyesrer RAL 7032 (*)
----------	---

\* altre verniciature sono disponibili su richiesta

\* other painting cycle are available on request

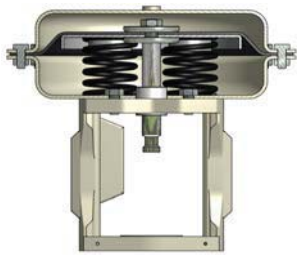

Fig. 1

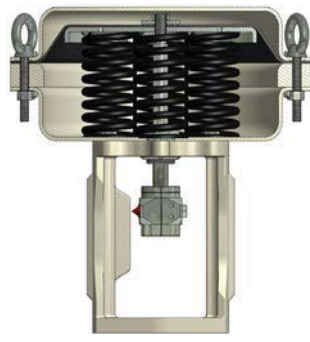

Fig. 3

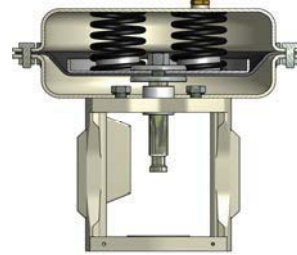

Fig. 2

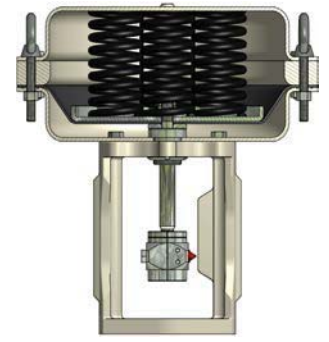

Fig. 4

AZIONE DIRETTA	Aria Chiude (Fig.1/ Fig.3)
AZIONE INVERSA	Aria Apre (Fig.2 / Fig.4)

DIRECT ACTION	Air to Close (Fig.1 / Fig.3)
REVERSE ACTION	Air to Open (Fig.2 / Fig.4)

### ACCESSORI DISPONIBILI

Contatti di allarme
Posizionatore elettropneumatico
Posizionatore pneumatico
Posizionatore SMART
Convertitore I/P
Trasmettitore di posizione
Filtro riduttore
Volantino di manovra
Elettrovalvole
Dispositivo pneumatico di blocco (Lock UP)

### ACCESSORIES

Alarm contacts
Elettropneumatic positioner
Pneumatic positioner
SMART positioner
I/P Converter
4-20 mA Position feedback
Air filter regulator
Top mounted handwheel
Solenoid valves
Lock-Up pneumatic device

### VARIANTI DISPONIBILI

Castello INOX
Custodia INOX
Viteria INOX

### OPTIONS

St. Steel yoke
St. Steel casing
St. Steel bolts & nuts

**DIMENSIONI**

**DIMENSIONS**

**GRUPPO CORPO - BODY ASSY**

SIZE	A inches (mm)		B inches (mm)		C inches (mm) - BONNET		
					<i>Otturatore Standard / Standard Trim</i>		
	ANSI 150	ANSI 300	ANSI 150	ANSI 300	Standard	Soffietto Bellows	Alettato / Prolungato Finned / Extended
1/2"	7,25 (184)	7,46(189,5)	1,87(47,6)	1,87(47,6)	5,08 (129)	8,98 (228)	6,81 (173)
3/4"	7,25 (184)	7,62(194)	1,94(49,25)	2,31(58,75)	5,08 (129)	8,98 (228)	6,81 (173)
1"	7,25 (184)	7,75(197)	2,11(53,95)	2,43(61,9)	5,08 (129)	8,98 (228)	6,81 (173)
1.5"	8,75 (222)	9,25(235)	2,50(63,5)	3,06(77,8)	5,04 (128)	8,90 (226)	7,28 (185)
2"	10,00 (254)	10,50(267)	3,00(76,2)	3,25(82,55)	5,04 (128)	8,90 (226)	7,28 (185)
3"	11,75(298.5)	12,5(318)	3,75(95,25)	4,12(104,75)	7,36 (187)	12,05 (306)	10,04 (260)
4"	13,88(352.5)	14,50(368)	4,5(114,3)	5,00(127)	7,24 (184)	12,09 (307)	12,20 (310)
6"	17,75(451)	18,62(473)	5,5(139,7)	6,25(158,75)	10,20 (259)	14,61 (371)	14,61 (371)
8"	21,38(543)	22,38(568)	6,75(171,45)	7,5(190,5)	11,18 (284)	15,59 (396)	15,59 (396)

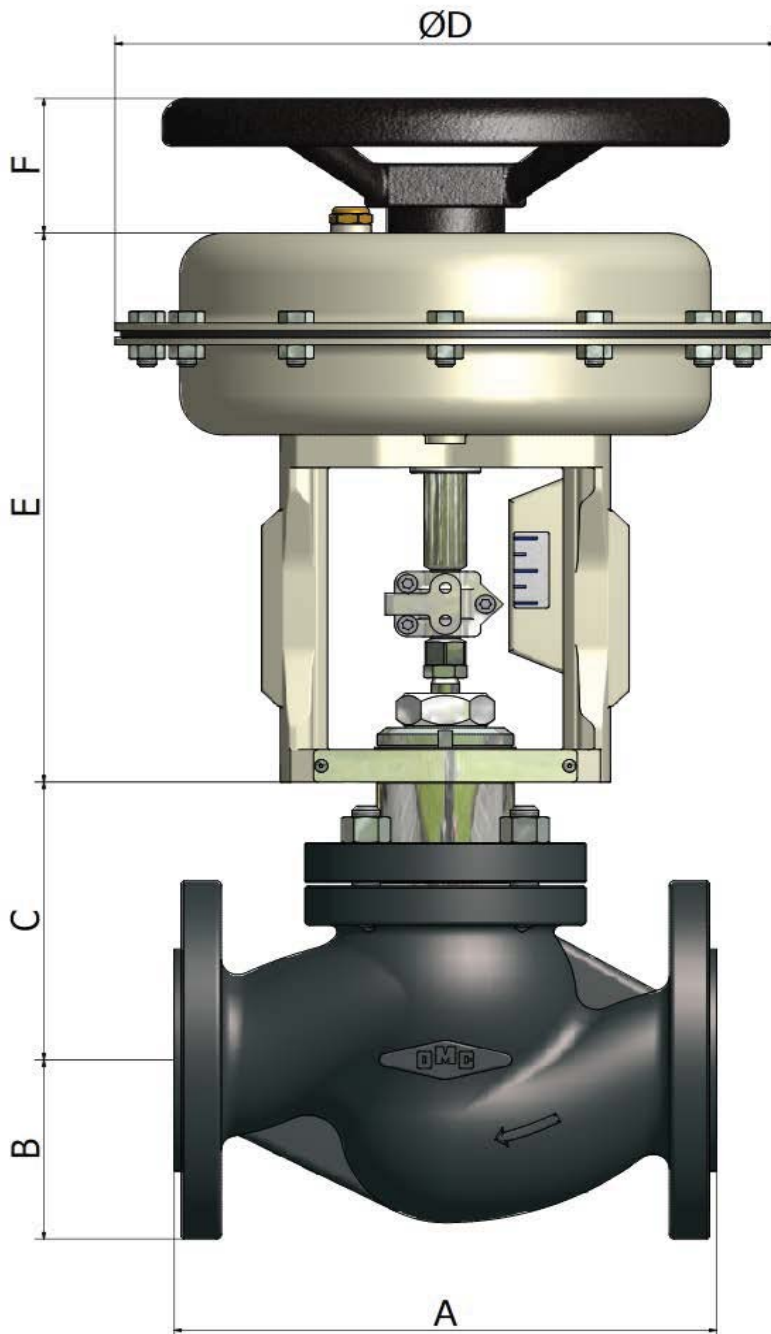

SIZE	C inches (mm) - BONNET		
	<i>Otturatore Bilanciato / Balanced Trim</i>		
	Standard	Soffietto Bellows	Alettato / Prolungato Finned / Extended
2"	6,18 (157)	10,07 (256)	8,42 (214)
3"	9,05 (230)	13,70 (348)	11,10 (282)
4"	9,64 (245)	14,48 (368)	12,20 (310)
6"	14,01 (356)	18,74 (476)	15,67 (398)
8"	14,96 (380)	19,68 (500)	16,61 (422)

SERVOMOTORE - ACTUATOR inches(mm)			
TIPO TYPE	Ø D	E	F
AP23	9,05(230)	9,64(245)	4,33(110)
AP28	10,82(275)	9,96(253)	4,33(110)
AP34 / AP35	13,19(335)	10,86(276)	5,90(150)
AP43 / AP44	16,93(430)	11,93(303)	11,8(300)
AP45	16,93(430)	15,47(393)	
AP46	16,93(430)	16,73(425)	
AP60	23,6(600)	17,72(450)	

AREA DI SPINTA SERVOMOTORE ACTUATOR THRUST AREA	
TIPO TYPE	AREA inch <sup>2</sup> (cm <sup>2</sup> )
AP23	31,46 (203)
AP28	47,12 (304)
AP34 / AP35	73,62 (475)
AP43 / AP44	115,32 (744)
AP45	
AP46	
AP60	262,95 (1690)

# ATTUATORE PNEUMATICO A PISTONE

# PISTON PNEUMATIC ACTUATOR

PRESSIONI DIFFERENZIALI MASSIME AMMISSIBILI IN  
BAR (Fluido Apre)

MAXIMUM PERMISSIBLE PRESSURE DROPS IN BAR  
(Fluid Open)

TYPE	Ø	SEGNALE SIGNAL	CV									
			0.05 ÷ 4.5	6	11	18	27	47	73	105	160	
OP10	1/2" ÷ 2"	6÷10 bar	175psi (12Bar)	175psi (12Bar)	175psi (12Bar)	175psi (12Bar)	175psi (12Bar)	145psi (10Bar)				
OP16	3" ÷ 4"	6÷10 bar								175psi (12Bar)	116psi (8Bar)	45psi (3Bar)

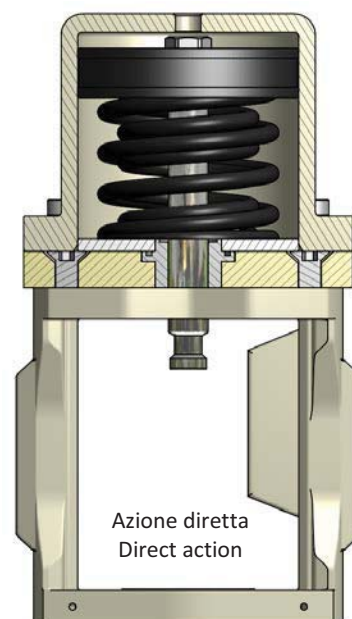
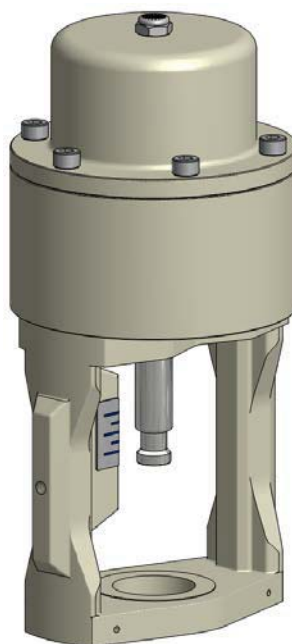
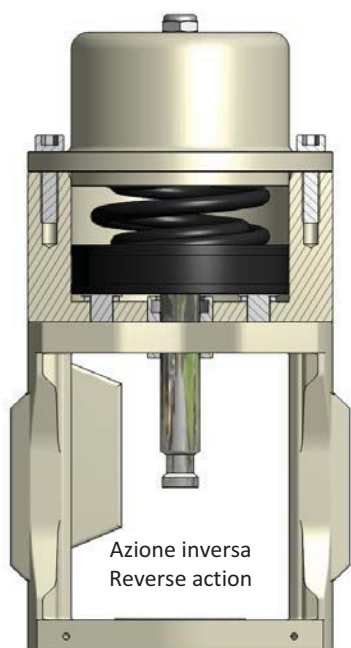

TIPO ATTUATORE	a pistone con multimolle interne	TYPE	piston type - multispring
SEGNALI DI COMANDO	da 90 psi (6 Bar) a 145psi(10 bar)	CONTROL SIGNAL	from 90psi(6 Bar) to 145psi(10bar)
MASSIMA PRESSIONE ARIA APPLICABILE	145 psi (10 bar)	MAX AIR SUPPLY PRESSURE	145 psi (10 bar)
TEMPERATURA AMBIENTE	-4÷160°F (-20÷70°C)	AMBIENT TEMPERATURE	-4÷160°F (-20÷70°C)
MATERIALE CASSA	Alluminio Verniciatura Epossidica RAL7021	ACTUATOR CASTING MATERIAL	Alluminium anti corrosive paint RAL7021
CASTELLO	Tipo Integrale in Acciaio al Carbonio	YOKE MATERIAL	Integral Type in Carbon Steel
CONNESSIONI PNEUMATICHE	1/4"NPT-F	PNEUMATIC CONNECTIONS	1/4"NPT-F

## ACCESSORI E VARIANTI DISPONIBILI

## OPTIONS AND ACCESSORIES

Contatti di allarme	Alarm contacts
Elettrovalvole	Solenoid valves
Verniciatura per ambienti Marini	Off-Shore painting

**DIMENSIONI**

**DIMENSIONS**

**GRUPPO CORPO - BODY ASSY**

SIZE	A inches (mm)		B inches (mm)		C inches (mm) - BONNET		
					<i>Otturatore Standard / Standard Trim</i>		
	ANSI 150	ANSI 300	ANSI 150	ANSI 300	Standard	Soffietto Bellows	Alettato / Prolungato Finned / Extended
1/2"	7,25 (184)	7,46(189,5)	1,87(47,6)	1,87(47,6)	5,08 (129)	8,98 (228)	6,81 (173)
3/4"	7,25 (184)	7,62(194)	1,94(49,25)	2,31(58,75)	5,08 (129)	8,98 (228)	6,81 (173)
1"	7,25 (184)	7,75(197)	2,11(53,95)	2,43(61,9)	5,08 (129)	8,98 (228)	6,81 (173)
1.5"	8,75 (222)	9,25(235)	2,50(63,5)	3,06(77,8)	5,04 (128)	8,90 (226)	7,28 (185)
2"	10,00 (254)	10,50(267)	3,00(76,2)	3,25(82,55)	5,04 (128)	8,90 (226)	7,28 (185)
3"	11,75(298.5)	12,5(318)	3,75(95,25)	4,12(104,75)	7,36 (187)	12,05 (306)	10,04 (260)
4"	13.88(352.5)	14,50(368)	4,5(114,3)	5,00(127)	7,24 (184)	12,09 (307)	12,20 (310)

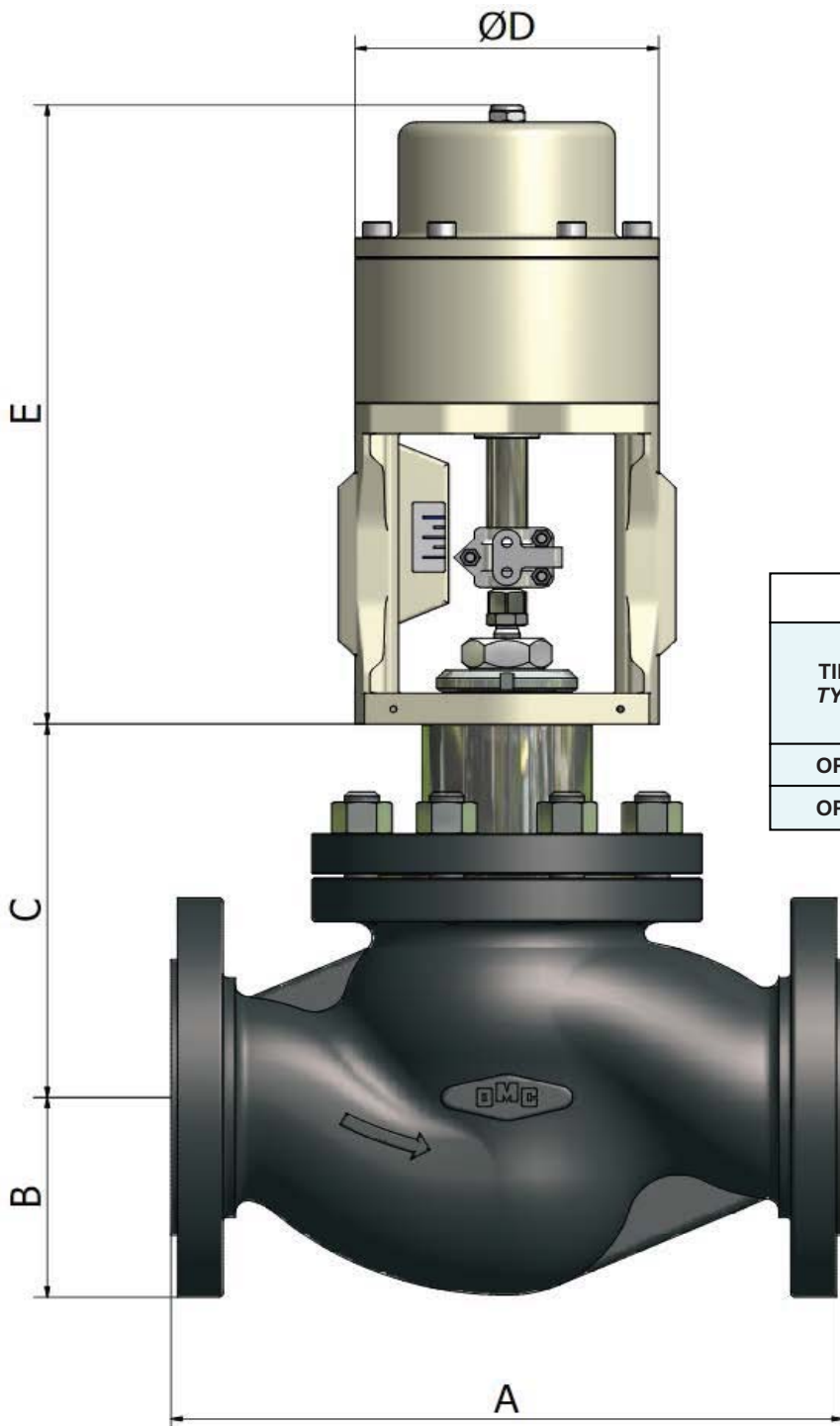

SIZE	C inches (mm) - BONNET		
	<i>Otturatore Bilanciato / Balanced Trim</i>		
	Standard	Soffietto Bellows	Alettato / Prolungato Finned / Extended
2"	6,18 (157)	10,07 (256)	8,42 (214)
3"	9,05 (230)	13,70 (348)	11,10 (282)
4"	9,64 (245)	14,48 (368)	12,20 (310)

SERVOMOTORE - ACTUATOR				
TIPO TYPE	$\varnothing D$ inches (mm)	E inches (mm)		
		3/4" - 1"½	2"	3" - 4"
OP10	5,51(140)	10,51(267)	11,50(292)	/
OP16	7,56(192)	/	/	13,19(335)

## ATTUATORE ELETTRICO

TIPO ATTUATORE	Elettrico
SEGNALI DI COMANDO	0+10 VDC - 2+10 VDC 0+20 mA - 4+20 mA
SEGNALE DI USCITA	0+10 VDC Std
GRADO DI PROTEZIONE STD	IP54

## ELECTRIC ACTUATOR

TYPE	Electric
CONTROL SIGNAL	0+10 VDC - 2+10 VDC 0+20 mA - 4+20 mA
OUTPUT SIGNAL	0+10 VDC Std
STD ENCLOSURE PROTECTION	IP54

TIPO	FORZA	CORSA MAX pollici (mm)	TEMPO DI AZIONAMENTO
MC 103	1.0 kN	0,78 (20 mm)	12 • 9 • 4 • 9 s/mm
MC 163	1.6 kN	1,18 (30 mm)	6 • 4 s/mm
MC 253	2,5 kN	2,36 (60 mm)	5 • 2,5 s/mm
MC 403	4 kN	2,36 (60 mm)	0,6 • 0,4 s/mm
MC 503	5 kN	2,36 (60 mm)	5 • 2,5 s/mm
MC 1003	10 kN	3,15 (80 mm)	1 s/mm
MC 1503	15 kN	3,15 (80 mm)	2 s/mm

TYPE	THRUST	MAX STROKE inches (mm)	ACTUATING TIME
MC 103	1.0 kN	0,78 (20 mm)	12 • 9 • 4 • 9 s/mm
MC 163	1.6 kN	1,18 (30 mm)	6 • 0,4 s/mm
MC 253	2,5 kN	2,36 (60 mm)	5 • 2,5 s/mm
MC 403	4 kN	2,36 (60 mm)	0,6 • 0,4 s/mm
MC 503	5 kN	2,36 (60 mm)	5 • 2,5 s/mm
MC 1003	10 kN	3,15 (80 mm)	1 s/mm
MC 1503	15 kN	3,15 (80 mm)	2 s/mm

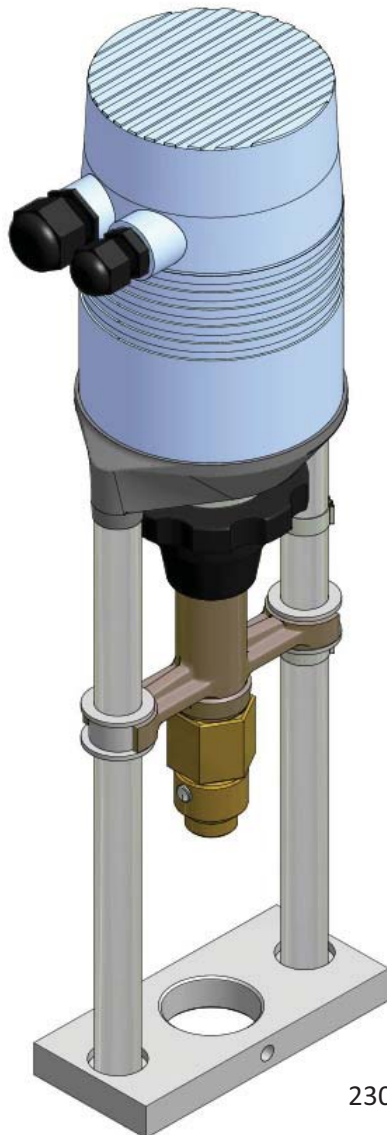

230Vac

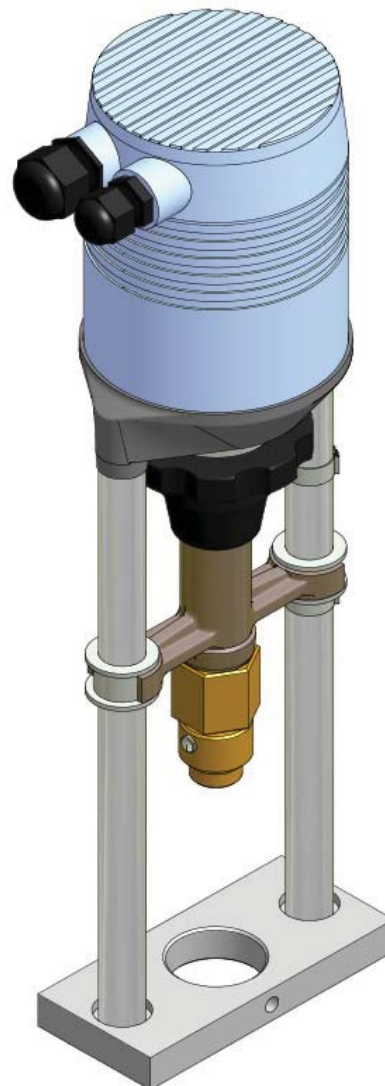

24Vac

**DIMENSIONI**

**DIMENSIONS**

**GRUPPO CORPO - BODY ASSY**

SIZE	A inches (mm)		B inches (mm)		C inches (mm) - BONNET		
	<i>Otturatore Standard / Standard Trim</i>						
	ANSI 150	ANSI 300	ANSI 150	ANSI 300	Standard	Soffietto Bellows	Alettato / Prolungato Finned / Extended
1/2"	7,25 (184)	7,46(189,5)	1,87(47,6)	1,87(47,6)	5,08 (129)	8,98 (228)	6,81 (173)
3/4"	7,25 (184)	7,62(194)	1,94(49,25)	2,31(58,75)	5,08 (129)	8,98 (228)	6,81 (173)
1"	7,25 (184)	7,75(197)	2,11(53,95)	2,43(61,9)	5,08 (129)	8,98 (228)	6,81 (173)
1.5"	8,75 (222)	9,25(235)	2,50(63,5)	3,06(77,8)	5,04 (128)	8,90 (226)	7,28 (185)
2"	10,00 (254)	10,50(267)	3,00(76,2)	3,25(82,55)	5,04 (128)	8,90 (226)	7,28 (185)
3"	11,75(298.5)	12,5(318)	3,75(95.25)	4,12(104.75)	7,36 (187)	12,05 (306)	10,04 (260)
4"	13.88(352.5)	14,50(368)	4,5(114.3)	5,00(127)	7,24 (184)	12,09 (307)	12,20 (310)
6"	17,75(451)	18,62(473)	5,5(139.7)	6,25(158.75)	10,20 (259)	14,61 (371)	14,61 (371)
8"	21,38(543)	22,38(568)	6,75(171.45)	7,5(190.5)	11,18 (284)	15,59 (396)	15,59 (396)

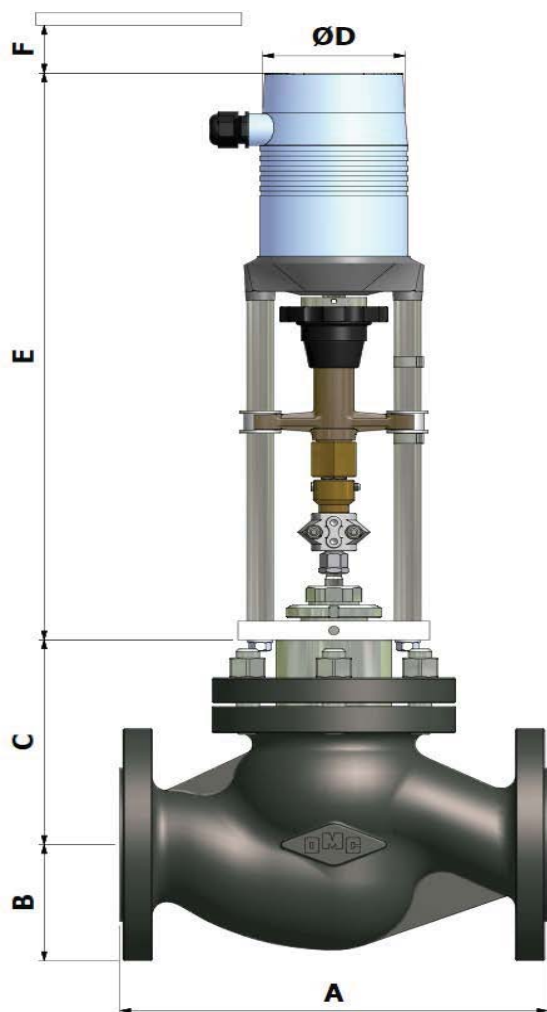

SIZE	C inches (mm) - BONNET		
	<i>Otturatore Bilanciato / Balanced Trim</i>		
	Standard	Soffietto Bellows	Alettato / Prolungato Finned / Extended
2"	6,18 (157)	10,07 (256)	8,42 (214)
3"	9,05 (230)	13,70 (348)	11,10 (282)
4"	9,64 (245)	14,48 (368)	12,20 (310)
6"	14,01 (356)	18,74 (476)	15,67 (398)
8"	14,96 (380)	19,68 (500)	16,61 (422)

TIPO TYPE	Ø D inches (mm)	E inches (mm)	F inches (mm)
MC 103 (24Vac)	3,94(100)	14,80(376)	5,51(140)
MC 103 (230Vac)	3,94(100)	15,78(401)	5,51(140)
MC 163 (24Vac)	3,94(100)	16,85(428)	5,51(140)
MC 163 (230Vac)	3,94(100)	17,83(453)	5,51(140)
MC 253 / MC 503	5,31(135)	26,38(670)	7,87(200)
MC 403	5,31(135)	26,38(670)	7,87(200)
MC 1003 / MC 1503	5,31(135)	30,31(770)	7,87(200)

**ACCESSORI E VARIANTI DISPONIBILI**

**OPTIONS AND ACCESSORIES**

Grado di protezione IP65
Ritrasmissione 4-20 mA
Finecorsa
Motori elettrici con molla di ritorno
Motori elettrici ATEX & explosion proof ( Exd )

Enclosure protection IP65
4-20 mA Feedback
Limit switches
Spring return electric actuator
ATEX & explosion proof (Exd) electric actuator

GRUPPO CORPO - BODY ASSY

SIZE	A inches (mm)	C inches (mm) - BONNET			C inches (mm) - BONNET		
		<i>Otturatore Standard / Standard Trim</i>			<i>Otturatore Bilanciato / Balanced Trim</i>		
		Standard	Soffietto Bellows	Alettato / Prolungato Finned / Extended	Standard	Soffietto Bellows	Alettato / Prolungato Finned / Extended
1/2"	7,46(189,5)	5,08 (129)	8,98 (228)	6,81 (173)	/	/	/
3/4"	7,62(194)	5,08 (129)	8,98 (228)	6,81 (173)			
1"	7,75(197)	5,08 (129)	8,98 (228)	6,81 (173)			
1.5"	9,25(235)	5,04 (128)	8,90 (226)	7,28 (185)			
2"	10,50(267)	5,04 (128)	8,90 (226)	7,28 (185)	6,18 (157)	10,07 (256)	8,42 (214)
3"	12,5(318)	7,36 (187)	12,05 (306)	10,04 (260)	9,05 (230)	13,70 (348)	11,10 (282)
4"	14,50(368)	7,24 (184)	12,09 (307)	12,20 (310)	9,64 (245)	14,48 (368)	12,20 (310)
6"	18,62(473)	10,20 (259)	14,61 (371)	14,61 (371)	14,01 (356)	18,74 (476)	15,67 (398)
8"	22,38(568)	11,18 (284)	15,59 (396)	15,59 (396)	14,96 (380)	19,68 (500)	16,61 (422)

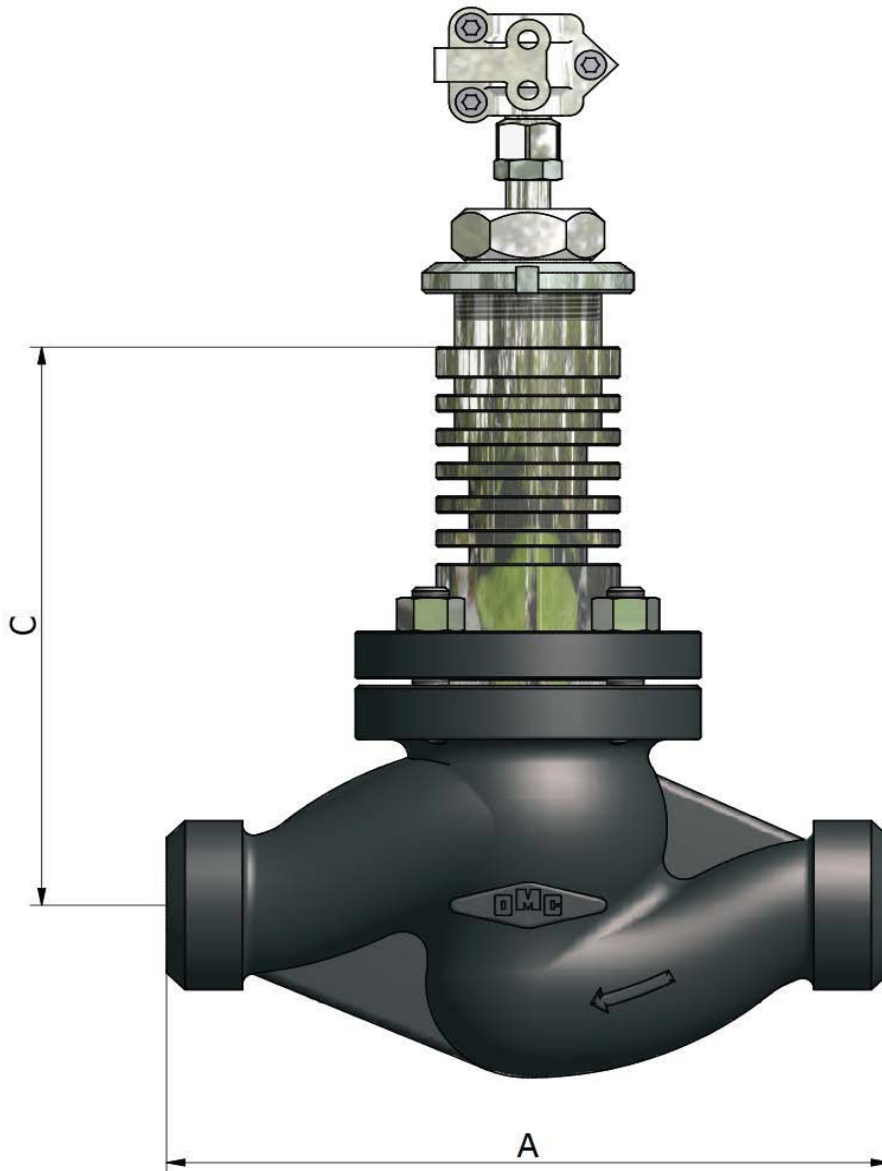

**PESI CORPI VALVOLA**

**VALVE BODY WEIGHT**

INCH	Standard (Kg)				Alettato (Kg) Finned (Kg)				Prolungato (Kg) Extended (Kg)				Soffietto (Kg) Bellows (Kg)			
	ANSI 150 WCC	ANSI 300 WCC	ANSI 150 CF8M	ANSI 300 CF8M	ANSI 150 WCC	ANSI 300 WCC	ANSI 150 CF8M	ANSI 300 CF8M	ANSI 150 WCC	ANSI 300 WCC	ANSI 150 CF8M	ANSI 300 CF8M	ANSI 150 WCC	ANSI 300 WCC	ANSI 150 CF8M	ANSI 300 CF8M
3/4"	6,2	6,9	6,3	7	6,5	7,2	6,6	7,3	6,7	7,4	6,8	7,5	7,4	8,1	7,5	8,2
1"	6,9	7,8	7	7,9	7,4	8,3	7,5	8,4	7,6	8,5	7,7	8,6	8	8,9	8,1	9
1" 1/2	11,2	14,9	12,2	15,1	11,8	14,5	12,8	15,7	12,3	16	13,4	16,3	12,9	16,5	13,9	16,8
2"	16,2	17,5	16,7	17,9	16,8	18	17,3	18,5	17,3	18,6	17,8	19	17,8	19,1	18,4	19,6
3"	34	37,5	34,6	38,1	35,9	39,3	36,5	40	37,1	40,5	37,7	41,2	38,2	41,6	38,8	42,3
4"	47,1	54	47,8	55,2	50,6	57,5	51,4	58,8	51,8	58,7	52,6	60	51	58	51,8	59,2
6"	126,5	138,4	128,6	142,8	132	143,9	134,2	148,4	134,4	146,3	136,6	150,8	133,2	145,1	135,4	149,6
8"	185,6	209,9	188,7	211,3	191,2	212,5	194,4	217	193,6	217,89	196,8	219,4	192,3	216,6	195,4	218,1

**PESI ATTUATORI PNEUMATICI**

**PNEUMATIC ACTUATOR WEIGHT**

TIPO TYPE	SEGNALE SIGNAL (psi)	ATTUATORE ACTUATOR Kg	VOLANTINO MANUALE HAND WHEEL Kg	TIPO TYPE	SEGNALE SIGNAL (psi)	ATTUATORE ACTUATOR Kg	VOLANTINO MANUALE HAND WHEEL Kg	TIPO TYPE	SEGNALE SIGNAL (psi)	ATTUATORE ACTUATOR Kg	VOLANTINO MANUALE HAND WHEEL Kg	
AP23	3÷15	7,3	1	AP34 / AP35	3÷15	14,7	2,1	AP45	15÷60	37,8	7,1	
	6÷18	7,4			6÷18	14,9			AP46	15÷60	44,8	7,1
	6÷30	7,3			6÷30	15				AP60	15÷60	155,5
	15÷60	7,8			15÷60	17,4			OP10		ON-OFF	7,5
AP28	3÷15	9,7	1	AP43 / AP44	3÷15	26	3	OP16		ON-OFF	12,5	//
	6÷18	9,8			6÷18	26,5						
	6÷30	9,6			6÷30	26,8						
	15÷60	11,5			15÷60	32,2			7,1			

**PESI ATTUATORI ELETTRICI**

**ELECTRIC ACTUATOR WEIGHT**

TIPO TYPE	24Vac Kg	230Vac Kg	TIPO TYPE	24Vac Kg	230Vac Kg	TIPO TYPE	24Vac Kg	230Vac Kg
MC 103	2,5	2,5	MC 403	9,5	9,5	MC 1503	11,5	11,5
MC 163	4	4	MC 503	7,4	8,6			
MC 253	7,4	8,6	MC 1003	11,5	11,5			

Il contenuto di questa pubblicazione è solo a scopo informativo. OMC si riserva di modificare o migliorare i disegni o le specifiche tecniche senza alcun preavviso  
 The contents of this publication are presented for information purpose only. We reserve to modify or improve the designs or specifications of such products at any time without notice.



**OMC s.r.l.**

Your Distributor:

**Coulton Instrumentation Ltd**

17 Somerford Business Park - Christchurch - BH23 3RU - UK

Tel: +44 1202 480 303 - E-mail: sales@coulton.com - Web: www.coulton.com